

ELECTRICAL COMPONENTS

PRODUCTS 2018/19





HORA eTec



Dirk Nierstrat, CEO

DEAR BUSINESS PARTNER,

First of all, welcome to our new HORA eTec product catalogue for 2018. We have seen a lot happen in recent times. We have achieved our path into entrepreneurial independence with the support of the BWK investment company after separating from the Leipold Group, of which our company had been a member from the mid-1990s up to the end of 2017.

We have developed a completely new corporate design, changing the word "Werk" in our old name to "eTec". We have changed our corporate signature colour from blue to red. Our distinctive signal-and-circle logo remains on our products worldwide to maintain brand awareness.

Our new product catalogue concludes this development for the time being. Our new company name, HORA eTec, ties directly into the focus of our endeavours – electrical engineering – while documenting our transformation from contract manufacturing only to supplying electrical technology systems. Opting for the colour red marks a departure from the many years of blue in our corporate history. Our new claim – experts in electrical technology since

Yours,

Dirk Nierstrat,
CEO, HORA eTec GmbH

1919 – sums up this development. We're not just another start-up launched on the market. HORA eTec has kept a great deal from the familiar HORA name. We still have the same reliable contacts. We remain true to our commitment of providing high quality at the best possible price, establishing and strengthening global partnerships in machined parts for this purpose while expanding into electrical technology components with worldwide distributors and our own regional offices.

There's a lot going on here. You might have noticed it from the energy we are putting into making things happen at HORA eTec. But don't just take my word for it, you'll see it reflected in our new product catalogue. We have created additional value for you and your customers in our ranges of terminal and sub-distribution blocks while broadening our phase distribution blocks and main line branch terminals.

Let's meet and talk about it.

We look forward to seeing you.



ALUMINIUM OR COPPER?
HORA eTec electric terminals
connect both materials.

CONTENT

Editorial Dirk Niestrat	3
HORA eTec: Expertise in Electrical Engineering since 1919	6
Electric terminals of HORA eTec	8

PRODUCTS

Distribution Blocks (PDB)	10
Distribution Blocks (UVB)	30
Main line branch terminals (HLAK)	36
Terminal Blocks (RKA)	58
Conductor Connection Terminals (SSAK)	74
Neutral Conductor Rails (NPES)	76
Busbars (PS) & Accessories	80
Aluminium Connector Terminals (ALAK)	92
Information	94



HORA eTec

Expertise in Electrical Engineering since 1919

HORA eTec's work begins where the development focus of many electric terminal suppliers ends. Our product range occupies a niche, which is an extension to the programs of established suppliers. Electrical terminals for aluminium conductors, electrical terminals for copper conductors: We have in-depth expertise in component cores to back up our solutions. We have been providing reliable brassworking services to partners since 1919, and are now among the leading manufacturers of machined parts used in electrical engineering while constantly extending our know-how in advanced materials such as aluminium.

We at Hora eTec broach terminal openings of all kinds, and have become experts in broaching technology. All the tools and equipment we use have been developed or built in-house. Our processing cross-sections for PCB terminals are for the smallest edge dimensions at 3.8 x 2.8 x 2 mm and for power distribution terminals at 44 x 28 x 50 mm. This means that the connection cross-sections are sufficient from 1.5 mm² to 10mm² for PCB terminals and for our power distribution terminals up to 1,000 mm².

Finishing processes such as blasting, vibratory grinding and thermal annealing round off our range of processes. We offer our customers individual solutions for screw mounting. Whether power distribution, building

services engineering or automation, our products and components – including electrical terminals, sockets, pin terminals and terminal blocks – can be found in every electrical engineering specialisation. Our large purchasing volumes for brass as a raw material combined with state-of-the-art manufacturing technology ensure excellent cost effectiveness in various batch sizes. Together with our Indian production partner, we are able to provide low production runs cost-effectively for our customers.

Our specialised expertise has secured our place as one of the most powerful brassworking companies in Europe. We have more than two hundred active customers on our books. Our services start at the very beginning – in the design process. We work along the entire value chain from development to production and logistics from our two locations in the East Westphalian region of Germany.

The extensive expertise shared by our employees helps us develop to serve our customers more effectively. We have a good eighty specialists in machining, electrical engineering, engineering and business-related fields to serve our customers. We're not only a manufacturer at HORA eTec, we provide solutions.



Guarantees for efficiency and safety

The HORA eTec electric terminals range

Increasing numbers of industrial applications require space-saving electric terminal solutions, raising demand for aluminium instead of copper conductors to cut costs. Connecting aluminium conductors is not always easy, as the material places high demands on the terminal. Not nearly all terminals are up to the task. HORA eTec terminals are user-friendly, cost-effective and safe. We follow the following application principles:

- Space saving
- Fast Assembly time
- Cost-effectiveness
- Safety

Compact electrical terminal design – quick and cost-effective in installation

HORA eTec terminals benefit from a compact and rugged design. Control cabinet construction benefits from up to thirty percent space savings in distribution blocks compared to conventional terminals using flat copper rails. Our electric terminals are quick and easy to install, ensuring shorter assembly times.

Cost savings are average twenty percent compared to conventional terminals on busbar systems. HORA eTec terminals do not need brake screws at all, thus keeping torque losses to a minimum during installation.

Safety assured on HORA eTec terminals

HORA eTec terminals are CE-compliant and approved according to all the major national and international testing standards, and separate power loss tests have

been performed on them. Labelling or colour-coding terminal connection points such as for neutral conductors makes it easy to assign different potentials and follow their power paths.

Electrical terminal compatibility with copper and aluminium conductors

Hora eTec terminals are suitable for use with copper and aluminium conductors. Copper dominates some markets such as Germany, allowing copper conductors to be connected conversely, aluminium conductors are the first option in aluminium-dominated markets such as the USA, Scandinavia and Eastern Europe; a specialised triple coating on our terminals makes this possible by ensuring secure, durable contact with aluminium conductors. We have been gradually expanding our range ever since we established this business division. The Hora eTec product range of electrical components consists of:

- Power distribution blocks
- Sub-distribution blocks
- Main line branch terminals
- Terminal blocks with an aluminium body
- Conductor connection terminals
- Neutral conductor rails
- Busbars and accessories
- Aluminium connector terminals

Applications include mechanical engineering, home and building services technology, industrial plant and equipment, automation, switchgear in electrical engineering, wind turbines, and solar technology.





PDB



POWER DISTRIBUTION BLOCKS (PDB)

Collecting and distributing power

POWER DISTRIBUTION BLOCKS (PDB)

Distribution blocks face increasing requirements. Power in plant and machinery often needs to be distributed to additional consumers such as motors – as efficiently as possible, of course. Conductor cross-sections of increasing sizes with minimum space requirements have placed the focus squarely on distribution blocks for users. The PDB series of distribution blocks from HORA eTec benefits from a high degree of user-friendliness, cost efficiency and safety, providing an ideal solution wherever power is supplied and distributed through conductors with relatively large cross-sections. Every version in the series has approval for connection to aluminium or copper conductors thanks to a specialised coating on the brass body throughout the component.

The design ensures excellent user-friendliness in HORA eTec distribution blocks. The step design in the brass body leaves conductor insertion in clear view at all times through a transparent cover. This makes assembly of the distribution blocks easy and safe while wiring up the terminals. Users already save costs due to the optimized design. The simplified screw assembly saves significant amounts of time. There are no torque losses during assembly as brake screws are not needed. Special chambers prevent loss of screws in the plastic casing. Whether quick mounting on a TS 35 rail according to IEC 60715 / DIN EN 50022 or directly screwed onto the mounting plate, HORA eTec distribution blocks are always easy and versatile to install.

HORA eTec distribution blocks are ideal for connecting round or flat conductors. The outputs feature a large number of smaller terminals for further power distribution. Apart from that, extending the number of outputs is easy and safe as the distribution blocks can be stacked and extended to any requirement using phase rails for smaller distribution blocks and pre-assembled flat copper bridges as accessories for larger ones. These accessories even make it possible to triple the number of outputs, allowing further power distribution from one input to large numbers of additional conductors instead of installing new supply lines. All distribution blocks can be combined freely with one another in a modular approach making it very easy to construct multipolar systems.

All versions are finger-safe on all sides according to DIN EN 50274, and also feature short-circuit resistance according to the exacting SCCR standard to add to the high level of safety. This means that HORA eTec distribution blocks meet current and constantly increasing safety requirements on terminal technology. Distribution blocks for neutral conductors are equipped with transparent blue covers. The plastic casing also includes individual connection labels. The ergonomic design with rounded edges as goods as eliminates the risk of injury during assembly.



PDB

PRODUCT BENEFITS

- > Suitable for all round and sector-shaped solid, stranded or flexible conductors in copper or aluminium
- > Cost savings from optimized brass body
- > innovative design with rounded edges
- > User-friendliness with simplified screw assembly, captive screws attached to the plastic casing, no brake screws needed
- > Universal round or flat conductor connections on a large number of terminals
- > Horizontal and vertical installation as well as free combination and stacking arrangement with component connections using conductor bridges

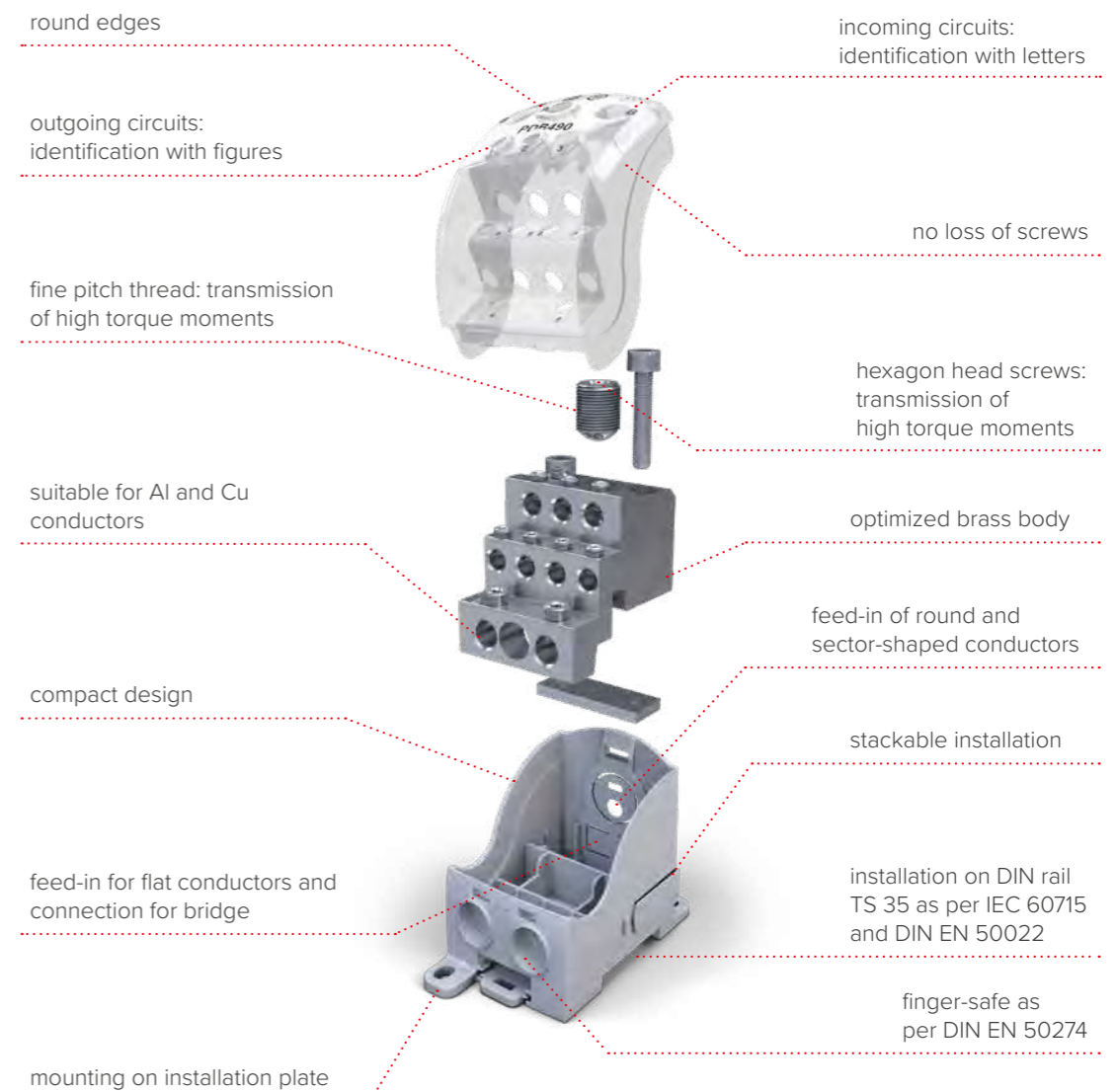

CERTIFICATES

- > IEC 60947-7-1
- > UL-1059
- > CSA C22.2 No.158-10



CONFORMITY



SAFETY



POWER DISTRIBUTION BLOCKS (PDB)

PDB 160 - 1 pole



082040-0-3

INCOMING

- 1 x 25 - 2,5 mm² (4 - 14 AWG)
- 16 - 1,5 mm² (6 - 16 AWG)

OUTGOING/BRIDGE

- 1 x 16 - 1,5 mm² (6 - 16 AWG)
- 10 - 1,5 mm² (8 - 16 AWG)
- 1 x oder
- Gabel M6 / 16 mm²

OUTGOING

- 2 x 16 - 1,5 mm² (6 - 16 AWG)
- 10 - 1,5 mm² (8 - 16 AWG)
- 3 x 10 - 1,5 mm² (8 - 16 AWG)
- 6 - 1,5 mm² (10 - 16 AWG)

- > modular system
- > user-defined stackable
- > to fit on DIN rail TS 35 or installation plate

CONNECTION OF 2 PDBS



082001-2-4

CONNECTION OF 3 PDBS

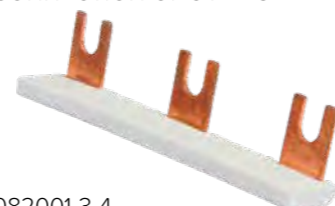

082001-3-4

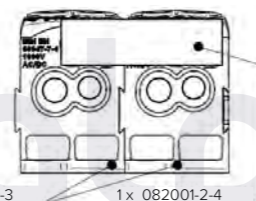

2 x 082040-0-3

1 x 082001-2-4

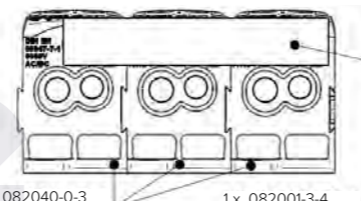

3 x 082040-0-3

1 x 082001-3-4

PDB 160 - 1 pole



082040-9-3

INCOMING

- 1 x 25 - 2,5 mm² (4 - 14 AWG)
- 16 - 1,5 mm² (6 - 16 AWG)

OUTGOING/BRIDGE

- 1 x 16 - 1,5 mm² (6 - 16 AWG)
- 10 - 1,5 mm² (8 - 16 AWG)
- 1 x oder
- Gabel M6 / 16 mm²

OUTGOING

- 2 x 16 - 1,5 mm² (6 - 16 AWG)
- 10 - 1,5 mm² (8 - 16 AWG)
- 3 x 10 - 1,5 mm² (8 - 16 AWG)
- 6 - 1,5 mm² (10 - 16 AWG)

- > modular system
- > user-defined stackable
- > to fit on DIN rail TS 35 or installation plate

CONNECTION OF 2 PDBS



082001-2-4

CONNECTION OF 3 PDBS



082001-3-4



2 x 082040-9-3

1 x 082001-2-4

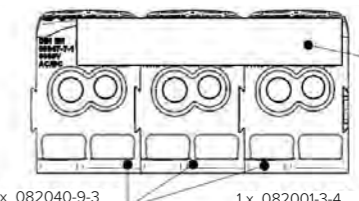

3 x 082040-9-3

1 x 082001-3-4

For aluminium and copper conductors (Al/Cu)



NOMINAL VOLTAGE	NOMINAL CURRENT	STANDARDS
1000 V AC/DC	164 A Cu (Incoming 2 x 16 mm ²)	IEC 60947-7-1
1000 V AC/DC	101 A Cu (Incoming 1 x 25 mm ²)	IEC 60947-7-1
600 V AC	85 A Cu / 65 A Al (Incoming 1 x 4 AWG)	UL-1059

Model	Part no.	Type	PU	GTIN / EAN
PDB 160	082040-0-3	PDB 160	1/36	4051589204033
Accessories				
for aluminium/ copper conductors	082001-2-4	Bridge for PDB 160 - 16mm ² - 2 Modules	20/360	4051589200127
	082001-3-4	Bridge for PDB 160 - 16mm ² - 3 Modules	20/360	4051589200134

For aluminium and copper conductors (Al/Cu)



NOMINAL VOLTAGE	NOMINAL CURRENT	STANDARDS
1000 V AC/DC	164 A Cu (Incoming 2 x 16 mm ²)	IEC 60947-7-1
1000 V AC/DC	101 A Cu (Incoming 1 x 25 mm ²)	IEC 60947-7-1
600 V AC	85 A Cu / 65 A Al (Incoming 1 x 4 AWG)	UL-1059

Model	Part no.	Type	PU	GTIN / EAN
PDB 160	082040-9-3	PDB 160	1/36	4051589204095
Accessories				
for aluminium/ copper conductors	082001-2-4	Bridge for PDB 160 - 16mm ² - 2 Modules	20/360	4051589200127
	082001-3-4	Bridge for PDB 160 - 16mm ² - 3 Modules	20/360	4051589200134

Power loss PDB 160

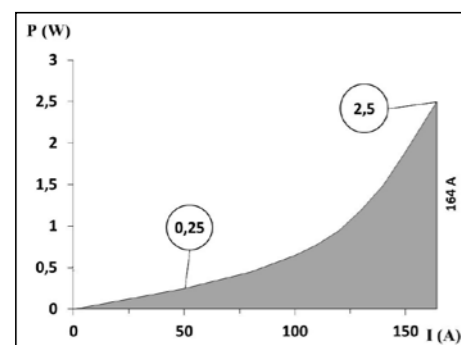

Dimensions:

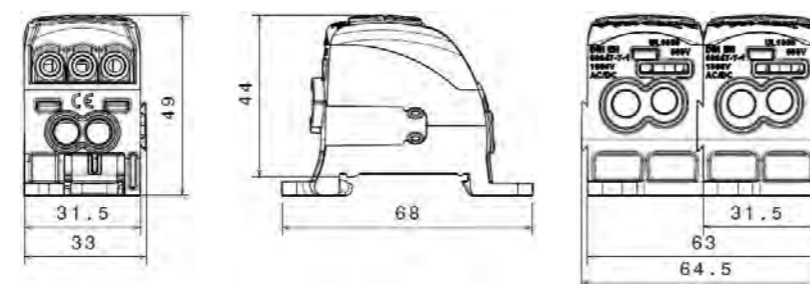

Power loss PDB 160

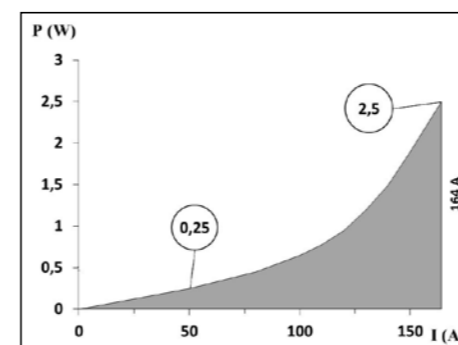

Dimensions:

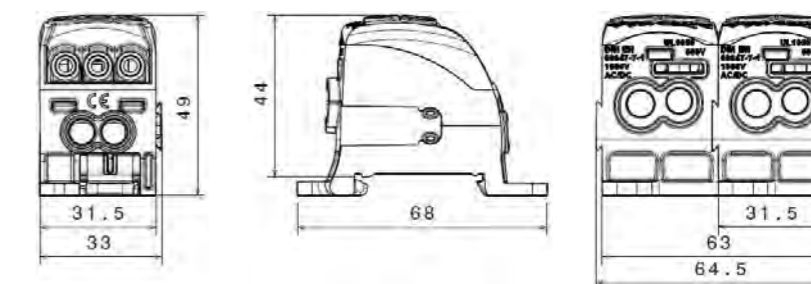

POWER DISTRIBUTION BLOCKS (PDB)

PDB 160 / 2 - double block ready assembled



082040-1-3

INCOMING		BRIDGE (READY ASSEMBLED)	
1 x	25 - 2,5 mm ² (4 - 14 AWG) 16 - 1,5 mm ² (6 - 16 AWG)	1 x	Fork M6 / 16 mm ²
OUTGOING			
4 x	16 - 1,5 mm ² (6 - 16 AWG) 10 - 1,5 mm ² (8 - 16 AWG)		
6 x	10 - 1,5 mm ² (8 - 16 AWG) 6 - 1,5 mm ² (10 - 16 AWG)		

- > modular system
- > user-defined stackable
- > to fit on DIN rail TS 35 or installation plate

PDB 160 / 2 - double block ready assembled



082040-8-3

INCOMING		BRIDGE (READY ASSEMBLED)	
1 x	25 - 2,5 mm ² (4 - 14 AWG) 16 - 1,5 mm ² (6 - 16 AWG)	1 x	Fork M6 / 16 mm ²
OUTGOING			
4 x	16 - 1,5 mm ² (6 - 16 AWG) 10 - 1,5 mm ² (8 - 16 AWG)		
6 x	10 - 1,5 mm ² (8 - 16 AWG) 6 - 1,5 mm ² (10 - 16 AWG)		

- > modular system
- > user-defined stackable
- > to fit on DIN rail TS 35 or installation plate



PDB

PDB 160 / 3 - triple block ready assembled



082040-2-3

INCOMING		BRIDGE (READY ASSEMBLED)	
1 x	25 - 2,5 mm ² (4 - 14 AWG) 16 - 1,5 mm ² (6 - 16 AWG)	1 x	Fork M6 / 16 mm ²
OUTGOING			
6 x	16 - 1,5 mm ² (6 - 16 AWG) 10 - 1,5 mm ² (8 - 16 AWG)		
9 x	10 - 1,5 mm ² (8 - 16 AWG) 6 - 1,5 mm ² (10 - 16 AWG)		

- > modular system
- > user-defined stackable
- > to fit on DIN rail TS 35 or installation plate

PDB 160 / 3 - triple block ready assembled



082040-7-3

INCOMING		BRIDGE (READY ASSEMBLED)	
1 x	25 - 2,5 mm ² (4 - 14 AWG) 16 - 1,5 mm ² (6 - 16 AWG)	1 x	Fork M6 / 16 mm ²
OUTGOING			
6 x	16 - 1,5 mm ² (6 - 16 AWG) 10 - 1,5 mm ² (8 - 16 AWG)		
9 x	10 - 1,5 mm ² (8 - 16 AWG) 6 - 1,5 mm ² (10 - 16 AWG)		

- > modular system
- > user-defined stackable
- > to fit on DIN rail TS 35 or installation plate

For aluminium and copper conductors (Al/Cu)



NOMINAL VOLTAGE	NOMINAL CURRENT	STANDARDS
1000 V AC/DC	164 A Cu (Incoming 2 x 16 mm ²)	IEC 60947-7-1
1000 V AC/DC	101 A Cu (Incoming 1 x 25 mm ²)	IEC 60947-7-1
600 V AC	85 A Cu / 65 A Al (Incoming 1 x 4 AWG)	UL-1059

Model	Part no.	Type	PU	GTIN /EAN
PDB 160	082040-1-3	PDB 160 / 2	1/14	4051589204132
	082040-2-3	PDB 160 / 3	1/14	4051589204231

for aluminium/copper conductors

Configuration:

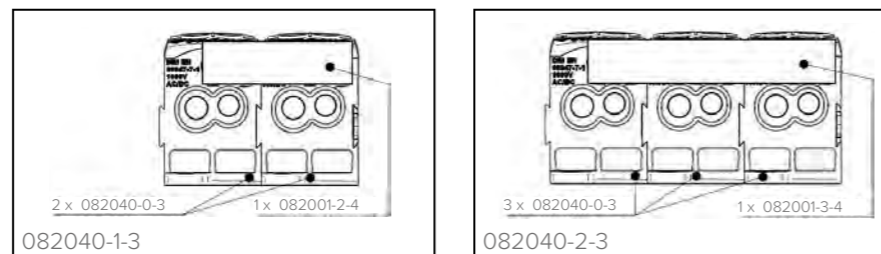

For aluminium and copper conductors (Al/Cu)



NOMINAL VOLTAGE	NOMINAL CURRENT	STANDARDS
1000 V AC/DC	164 A Cu (Incoming 2 x 16 mm ²)	IEC 60947-7-1
1000 V AC/DC	101 A Cu (Incoming 1 x 25 mm ²)	IEC 60947-7-1
600 V AC	85 A Cu / 65 A Al (Incoming 1 x 4 AWG)	UL-1059

Model	Part no.	Type	PU	GTIN /EAN
PDB 160	082040-8-3	PDB 160 / 2	1/14	4051589204088
	082040-7-3	PDB 160 / 3	1/14	4051589204071

for aluminium/copper conductors

Configuration:

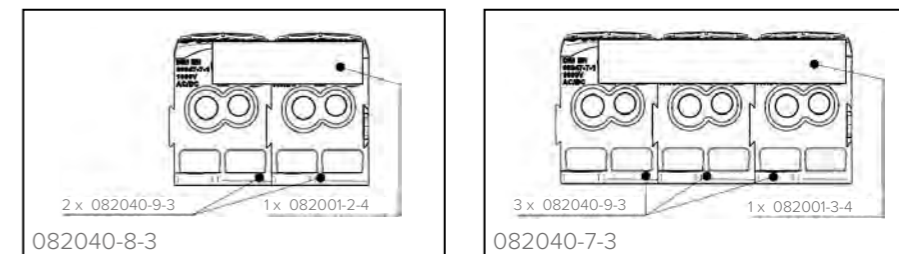

POWER DISTRIBUTION BLOCKS (PDB)

PDB 210 - 1 pole



082050-0-3

INCOMING

- 1 x 35 - 4 mm² (2 - 12 AWG)
- 25 - 2,5 mm² (4 - 14 AWG)

OUTGOING/BRIDGE

- 16 - 1,5 mm² (6 - 16 AWG)
- 10 - 1,5 mm² (8 - 16 AWG)
- 1 x or Fork M6 / 16 mm²

OUTGOING

- 2 x 25 - 2,5 mm² (4 - 14 AWG)
- 16 - 1,5 mm² (6 - 16 AWG)
- 3 x 16 - 1,5 mm² (6 - 16 AWG)
- 10 - 1,5 mm² (8 - 16 AWG)

- > modular system
- > user-defined stackable
- > to fit on DIN rail TS 35 or installation plate

CONNECTION OF 2 PDBS



082002-2-4

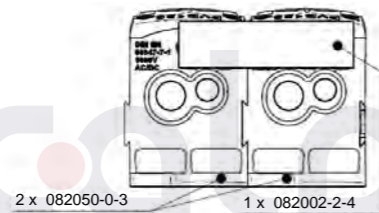

2 x 082050-0-3 1 x 082002-2-4

CONNECTION OF 3 PDBS

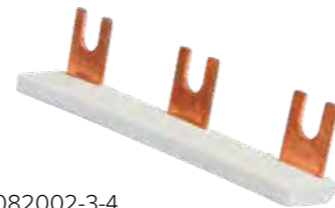

082002-3-4

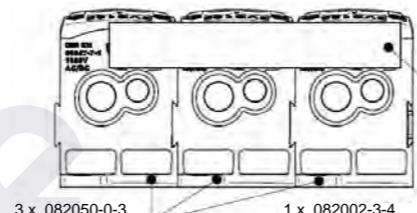

3 x 082050-0-3 1 x 082002-3-4

PDB 210 - 1 pole



082050-9-3

INCOMING

- 1 x 35 - 4 mm² (2 - 12 AWG)
- 25 - 2,5 mm² (4 - 14 AWG)

OUTGOING/BRIDGE

- 16 - 1,5 mm² (6 - 16 AWG)
- 10 - 1,5 mm² (8 - 16 AWG)
- 1 x or Fork M6 / 16 mm²

OUTGOING

- 2 x 25 - 2,5 mm² (4 - 14 AWG)
- 16 - 1,5 mm² (6 - 16 AWG)
- 3 x 16 - 1,5 mm² (6 - 16 AWG)
- 10 - 1,5 mm² (8 - 16 AWG)

- > modular system
- > user-defined stackable
- > to fit on DIN rail TS 35 or installation plate

CONNECTION OF 2 PDBS



082002-2-4

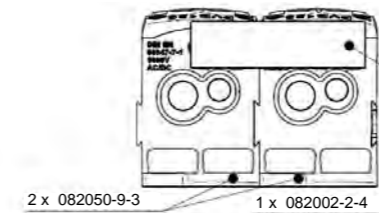

2 x 082050-9-3 1 x 082002-2-4

CONNECTION OF 3 PDBS

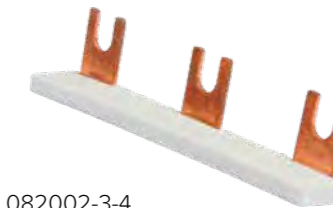

082002-3-4

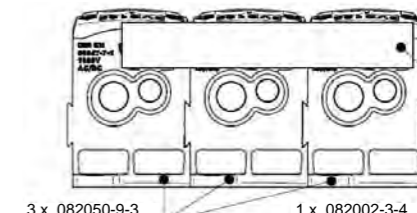

3 x 082050-9-3 1 x 082002-3-4



PDB

For aluminium and copper conductors (Al/Cu)



NOMINAL VOLTAGE	NOMINAL CURRENT	STANDARDS
1000 V AC/DC	214 A Cu Incoming 2 x 25 mm ²	IEC 60947-7-1
1000 V AC/DC	125 A Cu Incoming 1 x 35 mm ²	IEC 60947-7-1
600 V AC	115 A Cu / 90 A Al Incoming 1 x 2 AWG	UL-1059

Model	Part no.	Type	PU	GTIN / EAN
PDB 210	082050-0-3	PDB 210	1/36	4051589205030
Accessories				
for aluminium/ copper conductors	082002-2-4	Bridge for PDB 210 - 16mm ² - 2 modules	20/360	4051589200226
	082002-3-4	Bridge for PDB 210 - 16mm ² - 3 modules	20/360	4051589200233

For aluminium and copper conductors (Al/Cu)



NOMINAL VOLTAGE	NOMINAL CURRENT	STANDARDS
1000 V AC/DC	214 A Cu Incoming 2 x 25 mm ²	IEC 60947-7-1
1000 V AC/DC	125 A Cu Incoming 1 x 35 mm ²	IEC 60947-7-1
600 V AC	115 A Cu / 90 A Al Incoming 1 x 2 AWG	UL-1059

Model	Part no.	Type	PU	GTIN / EAN
PDB 210	082050-9-3	PDB 210	1/36	4051589205092
Accessories				
for aluminium/ copper conductors	082002-2-4	Bridge for PDB 210 - 16mm ² - 2 modules	20/360	4051589200226
	082002-3-4	Bridge for PDB 210 - 16mm ² - 3 modules	20/360	4051589200233

Power loss PDB 210

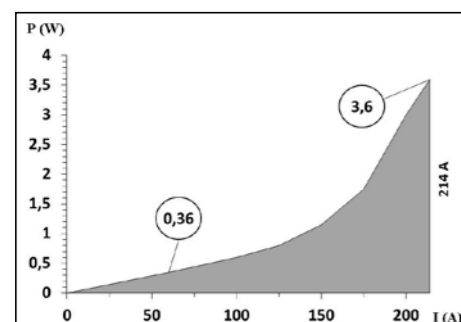

Dimensions:

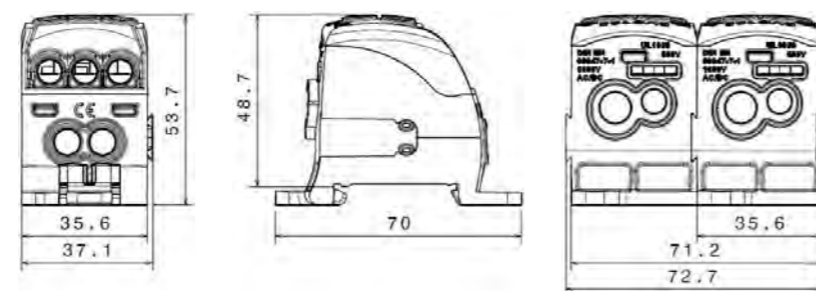

Power loss PDB 210

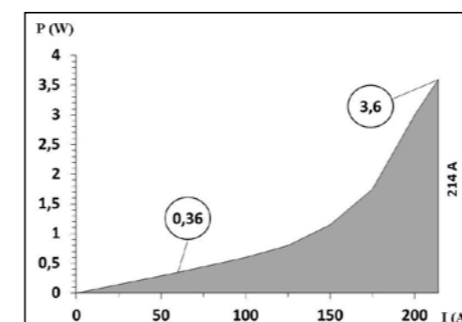

Dimensions:

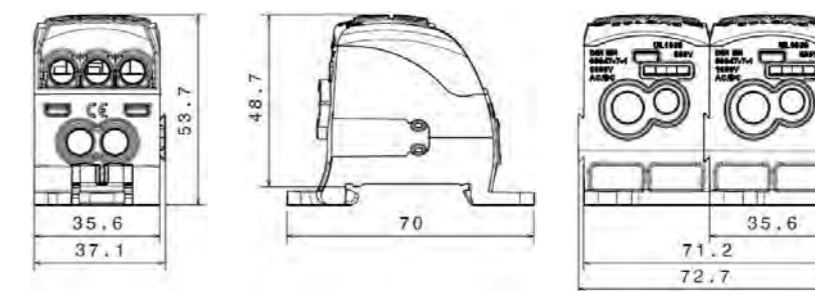

POWER DISTRIBUTION BLOCKS (PDB)

PDB 210 / 2 - double block ready assembled



082050-1-3

INCOMING		BRIDGE (READY ASSEMBLED)	
1 x	35 - 4 mm ² (2 - 12 AWG) 25 - 2,5 mm ² (4 - 14 AWG)	1 x	Fork M6 / 16 mm ²
OUTGOING			
4 x	25 - 2,5 mm ² (4 - 14 AWG) 16 - 1,5 mm ² (6 - 16 AWG)		
6 x	16 - 1,5 mm ² (6 - 16 AWG) 10 - 1,5 mm ² (8 - 16 AWG)		

- > modular system
- > user-defined stackable
- > to fit on DIN rail TS 35 or installation plate

PDB 210 / 2 - double block ready assembled



082050-8-3

INCOMING		BRIDGE (READY ASSEMBLED)	
1 x	35 - 4 mm ² (2 - 12 AWG) 25 - 2,5 mm ² (4 - 14 AWG)	1 x	Fork M6 / 16 mm ²
OUTGOING			
4 x	25 - 2,5 mm ² (4 - 14 AWG) 16 - 1,5 mm ² (6 - 16 AWG)		
6 x	16 - 1,5 mm ² (6 - 16 AWG) 10 - 1,5 mm ² (8 - 16 AWG)		

- > modular system
- > user-defined stackable
- > to fit on DIN rail TS 35 or installation plate



PDB

PDB 210 / 3 - triple block ready assembled



082050-2-3

INCOMING		BRIDGE (READY ASSEMBLED)	
1 x	35 - 4 mm ² (2 - 12 AWG) 25 - 2,5 mm ² (4 - 14 AWG)	1 x	Fork M6 / 16 mm ²
OUTGOING			
6 x	25 - 2,5 mm ² (4 - 14 AWG) 16 - 1,5 mm ² (6 - 16 AWG)		
9 x	16 - 1,5 mm ² (6 - 16 AWG) 10 - 1,5 mm ² (8 - 16 AWG)		

- > modular system
- > user-defined stackable
- > to fit on DIN rail TS 35 or installation plate

PDB 210 / 3 - triple block ready assembled



082050-7-3

INCOMING		BRIDGE (READY ASSEMBLED)	
1 x	35 - 4 mm ² (2 - 12 AWG) 25 - 2,5 mm ² (4 - 14 AWG)	1 x	Fork M6 / 16 mm ²
OUTGOING			
6 x	25 - 2,5 mm ² (4 - 14 AWG) 16 - 1,5 mm ² (6 - 16 AWG)		
9 x	16 - 1,5 mm ² (6 - 16 AWG) 10 - 1,5 mm ² (8 - 16 AWG)		

- > modular system
- > user-defined stackable
- > to fit on DIN rail TS 35 or installation plate

For aluminium and copper conductors (Al/Cu)



NOMINAL VOLTAGE	NOMINAL CURRENT		STANDARDS
1000 V AC/DC	214 A Cu	Incoming 2 x 25 mm ²	IEC 60947-7-1
1000 V AC/DC	125 A Cu	Incoming 1 x 35 mm ²	IEC 60947-7-1
600 V AC	115 A Cu / 90 A Al	Incoming 1 x 2 AWG	UL-1059

Model	Part no.	Type	PU	GTIN /EAN
PDB 210 for aluminium/ copper conductors	082050-1-3	PDB 210 / 2	1/14	4051589205139
	082050-2-3	PDB 210 / 3	1/14	4051589205238

Configuration:

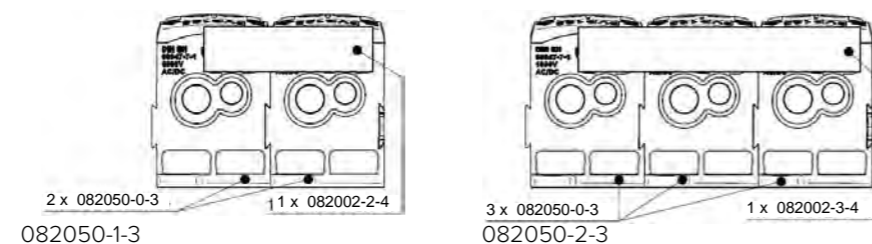

For aluminium and copper conductors (Al/Cu)



NOMINAL VOLTAGE	NOMINAL CURRENT		STANDARDS
1000 V AC/DC	214 A Cu	Incoming 2 x 25 mm ²	IEC 60947-7-1
1000 V AC/DC	125 A Cu	Incoming 1 x 35 mm ²	IEC 60947-7-1
600 V AC	115 A Cu / 90 A Al	Incoming 1 x 2 AWG	UL-1059

Model	Part no.	Type	PU	GTIN /EAN
PDB 210 for aluminium/ copper conductors	082050-8-3	PDB 210 / 2	1/14	4051589205085
	082050-7-3	PDB 210 / 3	1/14	4051589205078

Configuration:

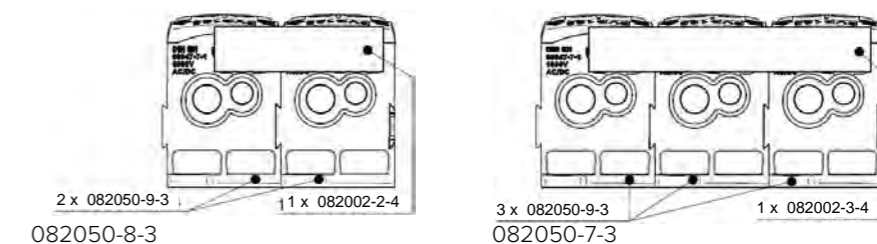

POWER DISTRIBUTION BLOCKS (PDB)

PDB 220



082060-0-3

INCOMING		OUTGOING	
1 x	70 - 10 mm ² (2/0 - 8 AWG) 50 - 6 mm ² (1/0 - 10 AWG)	2 x	25 - 2,5 mm ² (4 - 14 AWG) 16 - 1,5 mm ² (6 - 16 AWG)
1 x	Flat conductor 15,5 x 5 mm	3 x	16 - 1,5 mm ² (6 - 16 AWG) 10 - 1,5 mm ² (8 - 16 AWG)

- > modular system
- > user-defined stackable
- > to fit on DIN rail TS 35 or installation plate

CONNECTION OF 2 PDBS



ROUND OR FLAT CONDUCTOR FEED-IN



082003-2-4

PDB 220



082060-9-3

INCOMING		OUTGOING	
1 x	70 - 10 mm ² (2/0 - 8 AWG) 50 - 6 mm ² (1/0 - 10 AWG)	2 x	25 - 2,5 mm ² (4 - 14 AWG) 16 - 1,5 mm ² (6 - 16 AWG)
1 x	Flat conductor 15,5 x 5 mm	3 x	16 - 1,5 mm ² (6 - 16 AWG) 10 - 1,5 mm ² (8 - 16 AWG)

- > modular system
- > user-defined stackable
- > to fit on DIN rail TS 35 or installation plate

CONNECTION OF 2 PDBS



ROUND OR FLAT CONDUCTOR FEED-IN



082003-2-4



PDB

For aluminium and copper conductors (Al/Cu)



NOMINAL VOLTAGE	NOMINAL CURRENT	STANDARDS
1000 V AC/DC	215 A Cu Incoming Flexi Bar 4 x 15,5 mm	IEC 60947-7-1
1000 V AC/DC	192 A Cu Incoming 1 x 70 mm ²	IEC 60947-7-1
600 V AC	160 A Cu / 135 A Al Incoming 1 x 2/0 AWG	UL-1059

Model	Part no.	Type	PU	GTIN /EAN
PDB 220	082060-0-3	PDB 220	1/36	4051589206037
for aluminium/copper conductors	Accessories			
	082003-2-4	Bridge for PDB 220 - 35 mm ² - 2 modules	10/360	4051589200325

For aluminium and copper conductors (Al/Cu)



NOMINAL VOLTAGE	NOMINAL CURRENT	STANDARDS
1000 V AC/DC	215 A Cu Incoming Flexi Bar 4 x 15,5 mm	IEC 60947-7-1
1000 V AC/DC	192 A Cu Incoming 1 x 70 mm ²	IEC 60947-7-1
600 V AC	160 A Cu / 135 A Al Incoming 1 x 2/0 AWG	UL-1059

Model	Part no.	Type	PU	GTIN /EAN
PDB 220	082060-9-3	PDB 220	1/36	4051589206099
for aluminium/copper conductors	Accessories			
	082003-2-4	Bridge for PDB 220 - 35 mm ² - 2 modules	10/360	4051589200325

Power loss PDB 220

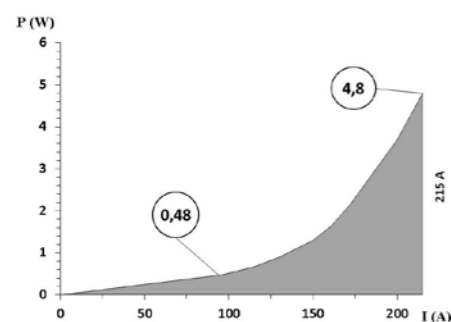

Dimensions:

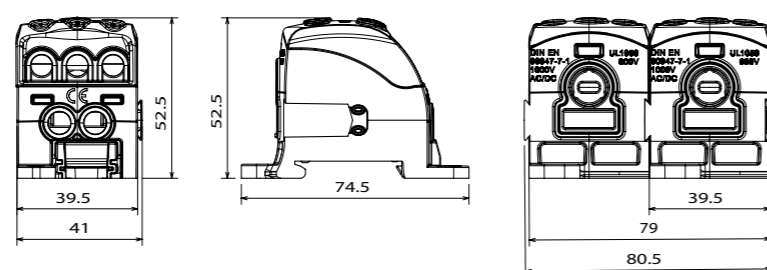

Power loss PDB 220

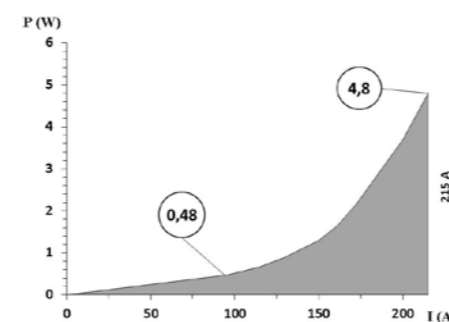

Dimensions:

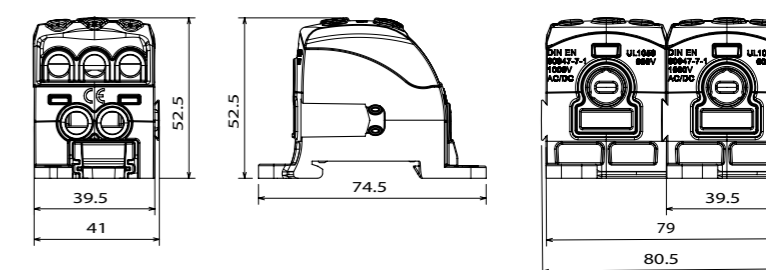

POWER DISTRIBUTION BLOCKS (PDB)

PDB 270



082070-0-3

INCOMING		OUTGOING/BRIDGE	
1 x	95 - 16 mm ² (3/0 - 6 AWG) 70 - 10 mm ² (2/0 - 8 AWG)	2 x	35 - 4 mm ² (2 - 12 AWG) 25 - 2,5 mm ² (4 - 14 AWG)
		OUTGOING	
8 x		25 - 2,5 mm ² (4 - 14 AWG) 16 - 1,5 mm ² (6 - 16 AWG)	

- > modular system
- > user-defined stackable
- > to fit on DIN rail TS 35 or installation plate

PDB 270



082070-9-3

INCOMING		OUTGOING/BRIDGE	
1 x	95 - 16 mm ² (3/0 - 6 AWG) 70 - 10 mm ² (2/0 - 8 AWG)	2 x	35 - 4 mm ² (2 - 12 AWG) 25 - 2,5 mm ² (4 - 14 AWG)
		OUTGOING	
8 x		25 - 2,5 mm ² (4 - 14 AWG) 16 - 1,5 mm ² (6 - 16 AWG)	

- > modular system
- > user-defined stackable
- > to fit on DIN rail TS 35 or installation plate



PDB



For aluminium and copper conductors (Al/Cu)



NOMINAL VOLTAGE	NOMINAL CURRENT	STANDARDS
1000 V AC/DC	270 A Cu Incoming 2 x 35 mm ²	IEC 60947-7-1
1000 V AC/DC	232 A Cu Incoming 1 x 95 mm ²	IEC 60947-7-1
600 V AC	200 A Cu / 155 A Al Incoming 1 x 3/0 AWG	UL-1059

Model	Part no.	Type	PU	GTIN /EAN
PDB 270	082070-0-3	PDB 270	1/18	4051589207034

for aluminium/copper conductors

For aluminium and copper conductors (Al/Cu)



NOMINAL VOLTAGE	NOMINAL CURRENT	STANDARDS
1000 V AC/DC	270 A Cu Incoming 2 x 35 mm ²	IEC 60947-7-1
1000 V AC/DC	232 A Cu Incoming 1 x 95 mm ²	IEC 60947-7-1
600 V AC	200 A Cu / 155 A Al Incoming 1 x 3/0 AWG	UL-1059

Model	Part no.	Type	PU	GTIN /EAN
PDB 270	082070-9-3	PDB 270	1/18	4051589207096

for aluminium/copper conductors

Power loss PDB 270

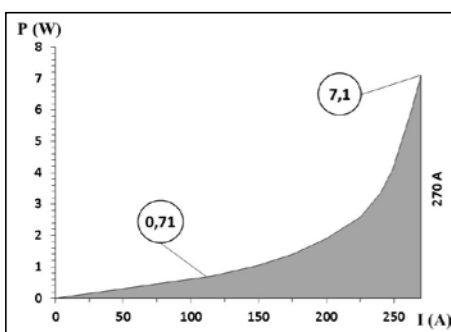

Dimensions:

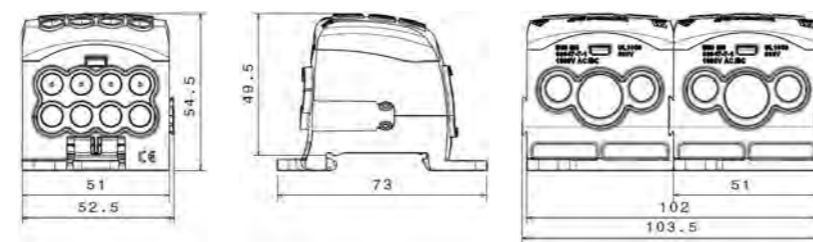

Power loss PDB 270

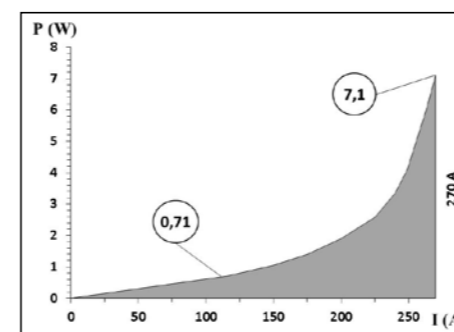

Dimensions:

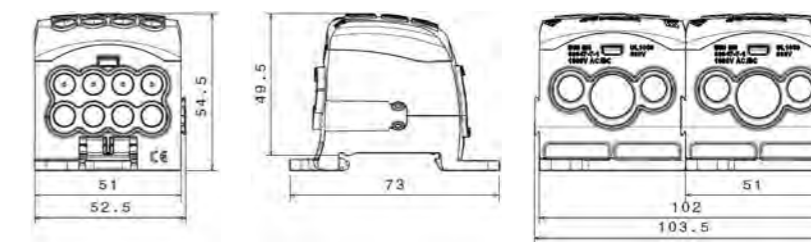

POWER DISTRIBUTION BLOCKS (PDB)

PDB 400



082080-0-3

INCOMING		OUTGOING	
1 x	120 - 35 mm ² (250 - 2 AWG) 95 - 25 mm ² (3/0 - 4 AWG)	2 x	35 - 4 mm ² (2 - 12 AWG) 25 - 2,5 mm ² (4 - 14 AWG)
1 x	Flat conductor 24 x 10 mm	3 x	25 - 2,5 mm ² (4 - 14 AWG) 16 - 1,5 mm ² (6 - 16 AWG)
		4 x	16 - 1,5 mm ² (6 - 16 AWG) 10 - 1,5 mm ² (8 - 16 AWG)

- > modular system
- > user-defined stackable
- > to fit on DIN rail TS 35 or installation plate



ROUND OR FLAT CONDUCTOR FEED-IN

CONNECTION OF 2 PDBS



082004-2-4

PDB 400



082080-9-3

INCOMING		OUTGOING	
1 x	120 - 35 mm ² (250 - 2 AWG) 95 - 25 mm ² (3/0 - 4 AWG)	2 x	35 - 4 mm ² (2 - 12 AWG) 25 - 2,5 mm ² (4 - 14 AWG)
1 x	Flat conductor 24 x 10 mm	3 x	25 - 2,5 mm ² (4 - 14 AWG) 16 - 1,5 mm ² (6 - 16 AWG)
		4 x	16 - 1,5 mm ² (6 - 16 AWG) 10 - 1,5 mm ² (8 - 16 AWG)

- > modular system
- > user-defined stackable
- > to fit on DIN rail TS 35 or installation plate



ROUND OR FLAT CONDUCTOR FEED-IN

CONNECTION OF 2 PDBS



082004-2-4



PDB

For aluminium and copper conductors (Al/Cu)



NOMINAL VOLTAGE	NOMINAL CURRENT	STANDARDS
1000 V AC / 1500 V DC	400 A Cu Incoming Flexi Bar 24x10 mm	IEC 60947-7-1
1000 V AC / 1500 V DC	250 A Cu Incoming 1 x 120 mm ²	IEC 60947-7-1
600 V AC	250 A Cu / 205 A Al Incoming 1 x 250 kcmil	UL-1059

Model	Part no.	Type	PU	GTIN /EAN
PDB 400	082080-0-3	PDB 400	1/18	4051589208031
for aluminium/ copper conductors	Accessories			
	082004-2-4	Bridge for PDB 400/490 - 95 mm ² - 2 modules	5/180	4051589200424

Power loss PDB 400

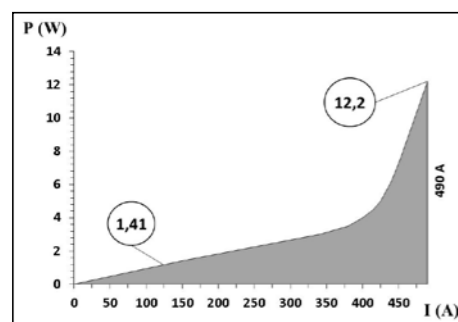

Dimensions:

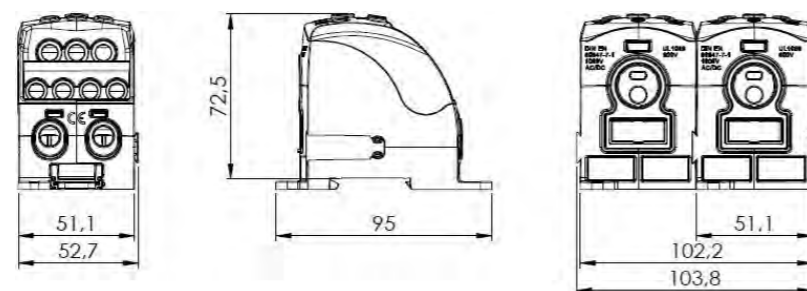

For aluminium and copper conductors (Al/Cu)



NOMINAL VOLTAGE	NOMINAL CURRENT	STANDARDS
1000 V AC / 1500 V DC	400 A Cu Incoming Flexi Bar 24x10 mm	IEC 60947-7-1
1000 V AC / 1500 V DC	250 A Cu Incoming 1 x 120 mm ²	IEC 60947-7-1
600 V AC	250 A Cu / 205 A Al Incoming 1 x 250 kcmil	UL-1059

Model	Part no.	Type	PU	GTIN /EAN
PDB 400	082080-9-3	PDB 400	1/18	4051589208093
for aluminium/ copper conductors	Accessories			
	082004-2-4	Bridge for PDB 400/490 - 95 mm ² - 2 modules	5/180	4051589200424

Power loss PDB 400

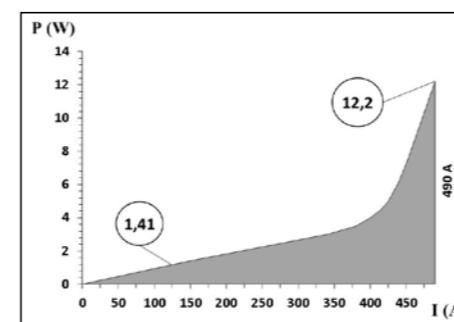

Dimensions:

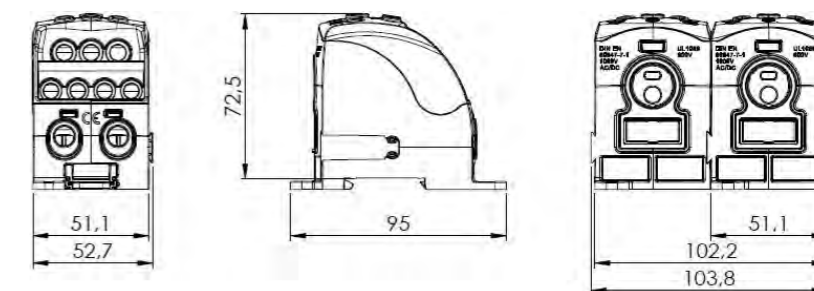

POWER DISTRIBUTION BLOCKS (PDB)

PDB 490



082090-0-3

INCOMING		OUTGOING	
1 x	185 - 95 mm ² (350 - 3/0 AWG) 150 - 70 mm ² (300 - 2/0 AWG)	2 x	35 - 4 mm ² (2 - 12 AWG) 25 - 2,5 mm ² (4 - 14 AWG)
1 x	Flat conductor 24 x 10 mm	3 x	25 - 2,5 mm ² (4 - 14 AWG) 16 - 1,5 mm ² (6 - 16 AWG)
		4 x	16 - 1,5 mm ² (6 - 16 AWG) 10 - 1,5 mm ² (8 - 16 AWG)

- > modular system
- > user-defined stackable
- > to fit on DIN rail TS 35 or installation plate



ROUND OR FLAT CONDUCTOR FEED-IN

CONNECTION OF 2 PDBS



082004-2-4

PDB 490



082090-9-3

INCOMING		OUTGOING	
1 x	185 - 95 mm ² (350 - 3/0 AWG) 150 - 70 mm ² (300 - 2/0 AWG)	2 x	35 - 4 mm ² (2 - 12 AWG) 25 - 2,5 mm ² (4 - 14 AWG)
1 x	Flat conductor 24 x 10 mm	3 x	25 - 2,5 mm ² (4 - 14 AWG) 16 - 1,5 mm ² (6 - 16 AWG)
		4 x	16 - 1,5 mm ² (6 - 16 AWG) 10 - 1,5 mm ² (8 - 16 AWG)

- > modular system
- > user-defined stackable
- > to fit on DIN rail TS 35 or installation plate



ROUND OR FLAT CONDUCTOR FEED-IN

CONNECTION OF 2 PDBS



082004-2-4



PDB

For aluminium and copper conductors (Al/Cu)



NOMINAL VOLTAGE	NOMINAL CURRENT	STANDARDS
1000 V AC / 1500 V DC	490 A Cu Incoming Flexi Bar 24 x 10 mm	IEC 60947-7-1
1000 V AC / 1500 V DC	353 A Cu Incoming 1 x 185 mm ²	IEC 60947-7-1
600 V AC	310 A Cu / 250 A Al Incoming 1 x 350 kcmil	UL-1059

Model	Part no.	Type	PU	GTIN /EAN
PDB 490	082090-0-3	PDB 490	1/18	4051589209038
for aluminium/copper conductors	Accessories			
	082004-2-4	Bridge for PDB 400/490 - 95 mm ² - 2 modules	5/180	4051589200424

For aluminium and copper conductors (Al/Cu)



NOMINAL VOLTAGE	NOMINAL CURRENT	STANDARDS
1000 V AC / 1500 V DC	490 A Cu Incoming Flexi Bar 24 x 10 mm	IEC 60947-7-1
1000 V AC / 1500 V DC	353 A Cu Incoming 1 x 185 mm ²	IEC 60947-7-1
600 V AC	310 A Cu / 250 A Al Incoming 1 x 350 kcmil	UL-1059

Model	Part no.	Type	PU	GTIN /EAN
PDB 490	082090-9-3	PDB 490	1/18	4051589209090
for aluminium/copper conductors	Accessories			
	082004-2-4	Bridge for PDB 400/490 - 95 mm ² - 2 modules	5/180	4051589200424

Power loss PDB 490

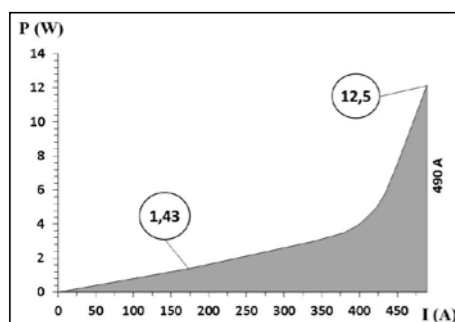

Dimensions:

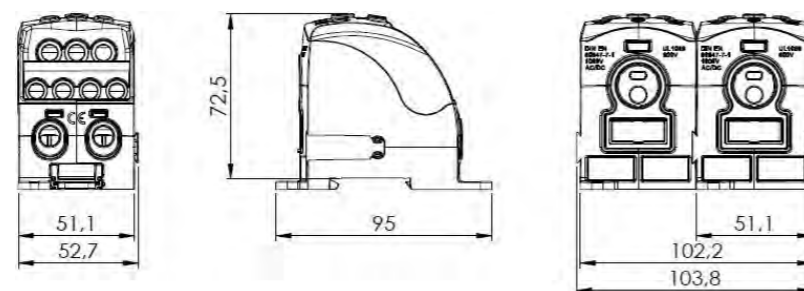

Power loss PDB 490

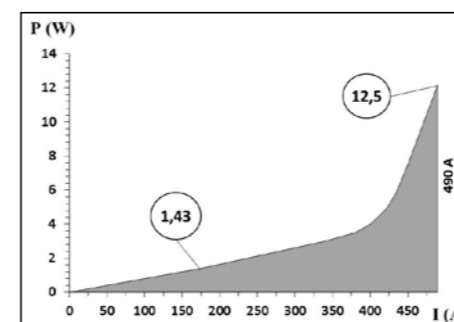

Dimensions:

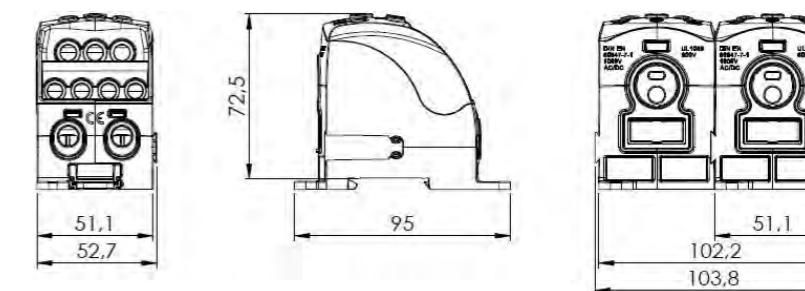

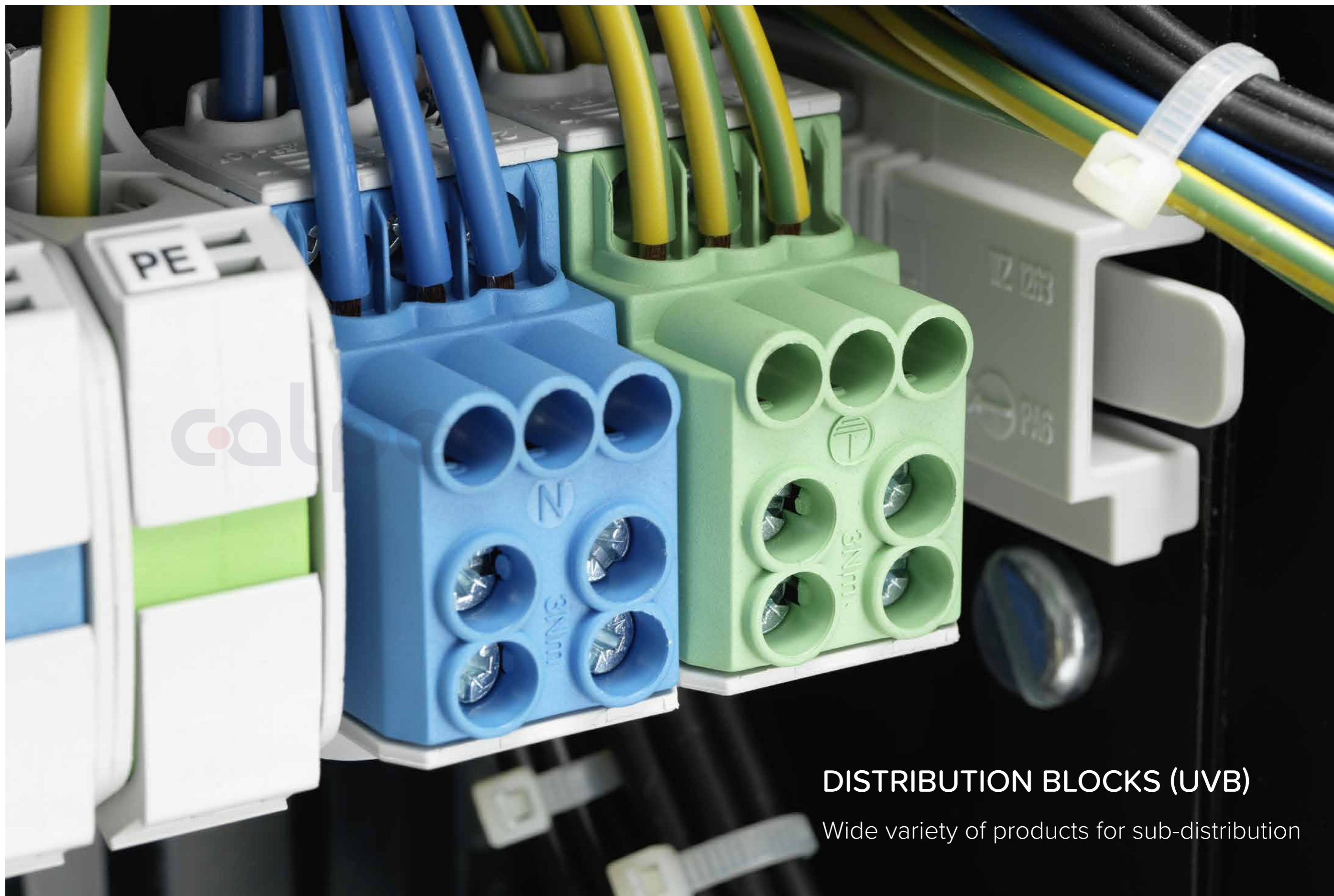

DISTRIBUTION BLOCKS (UVB)

Wide variety of products for sub-distribution

DISTRIBUTION BLOCKS (UVB)

Sub-distribution blocks are often used in sub-distribution and localised systems. HORA eTec UVB series models are also suitable for a host of other power distribution systems. The HORA eTec range includes a large product family accommodating a variety of cross-sections. All models are suitable for round or sector-shaped solid, stranded or flexible conductors in copper or aluminium.

HORA eTec supplies a new sub-distribution block model for up to 50 mm cross-section and a maximum capacity of 200A alongside common sub-distribution blocks with conductor cross-sections of up to 25 mm and rated current of 100A. The new UVB 200 sub-distribution block model is fitted with a hollow (square) main connector, allowing wire-end ferrules of any shape to be installed and connected with ease. HORA eTec sub-distribution blocks benefit from a highly compact design. This alone saves costs due to the low footprint.

This compactness and optimized brass body saves additional costs, not only from the space savings but also the additional user-friendly features sustainably reducing installation times. The simplified screw mounting with captive screws makes sub-distribution block installation easy and safe. There are no torque losses during assembly as brake screws are not needed.

Sub-distribution blocks are highly versatile, as they are already fitted with numerous terminals. Apart from that, the sub-distribution blocks are easy to extend by stacking and bridging with conductors. HORA eTec sub-distribution blocks in combinations of at least two can be mounted horizontally or vertically on TS 35 rails according to IEC 60715/DIN EN 50022 using specialised click-in technology.

All new sub-distribution block models are marked on the surface of the plastic casing at the terminals for the respective conductors, an additional feature that makes installation so much easier. The innovative step design on the brass body provides an unrestricted view of conductor insertions.

All sub-distribution blocks fulfil the EC Directive on the Restriction of Hazardous Substances in Electrical and Electronic Equipment (RoHS). These sub-distribution blocks have multiple approvals for use with aluminium and copper conductors. HORA eTec also provides optional custom branding, and custom industrial packaging is also available for product delivery.



PRODUCT BENEFITS

- > Suitable for all round and sector-shaped solid, stranded or flexible conductors in copper or aluminium
- > Cost savings from optimized brass body and compact design
- > User-friendliness with simplified screw assembly, captive screws attached to the plastic casing, no brake screws needed
- > Universal connection for conductors on large numbers of terminals
- > Horizontal installation as well as free combination and stacking arrangement with component connections using conductor bridges



UVB

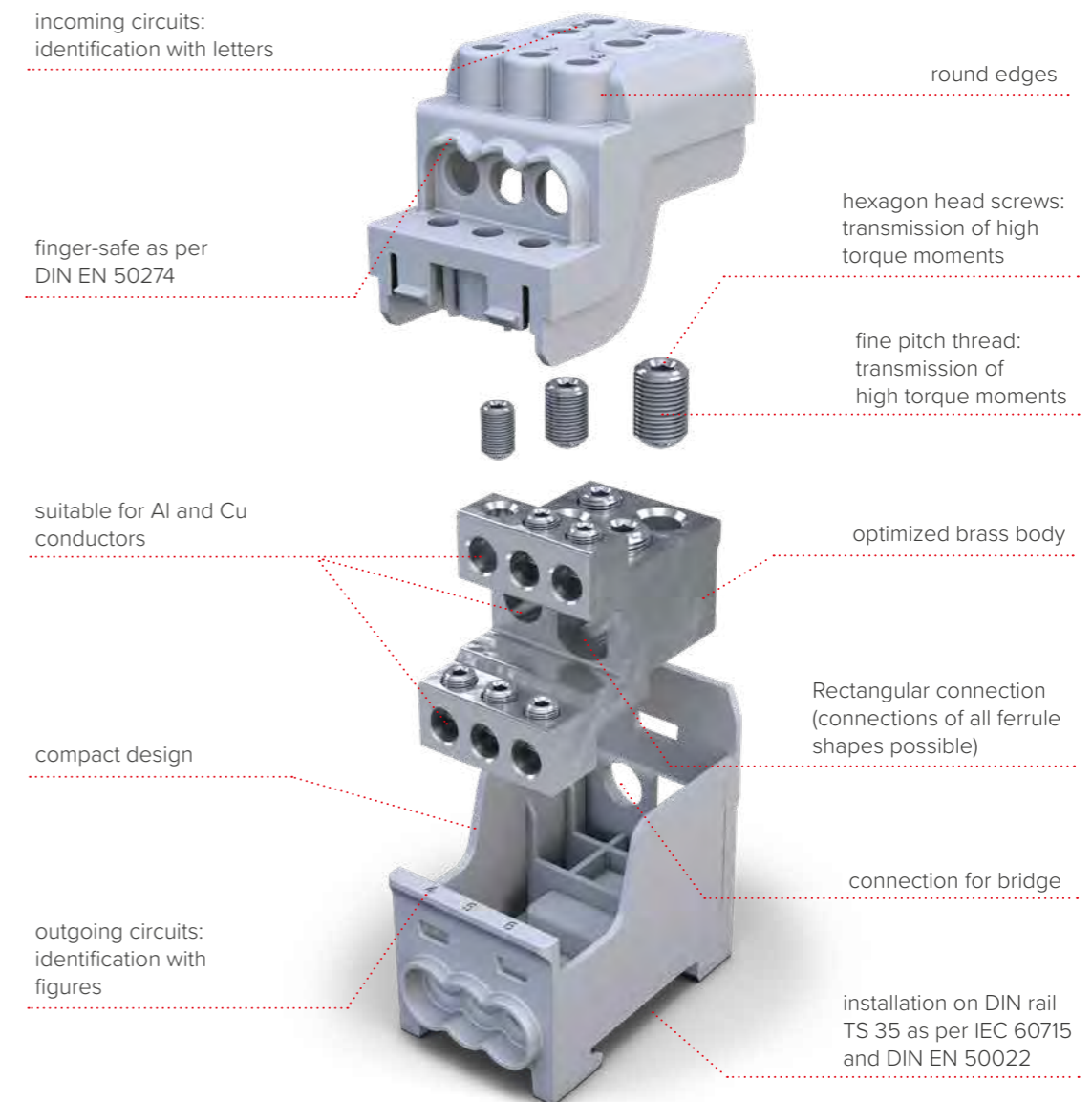

CERTIFICATES

- > IEC 60947-7-1
- > IEC 60998-1
- > IEC 61238-1 (Class A)



CONFORMITY



SAFETY



DISTRIBUTION BLOCKS (UVB)

UVB 100 - 1 pole



080010-0-X

INCOMING/BRIDGE

2 x 25 mm² - 2,5 mm²
16 mm² - 1,5 mm²



OUTGOING

6 x 10 mm² - 1,5 mm²
6 mm² - 1,5 mm²



- > modular system
- > user-defined stackable
- > to fit on DIN rail TS 35



AL/CU



080010-1-X



080010-2-X



080010-3-X



080010-4-X

UVB 200 - 1 pole



080030-0-X

INCOMING

1 x 70 - 10 mm²
50 - 6 mm²



OUTGOING/BRIDGE

1 x 35 - 4 mm²
25 - 2,5 mm²



- > modular system
- > user-defined stackable
- > to fit on DIN rail TS 35

AL/CU



080030-1-X



080030-2-X



080030-3-X



080030-4-X



For aluminium and copper conductors (Al/Cu)



NOMINAL VOLTAGE	NOMINAL CURRENT	STANDARDS
1000 V AC	100 A Al	IEC 61238-1 (Class A)
1000 V AC	101 A Cu	EN 60998-2-1

Model	Part no.	Type	PU	GTIN / EAN
UVB 100 for aluminium/ copper conductors	080010-0-3	UVB 100 L G	3/54	4051589001038
	080010-1-3	UVB 100 N	3/54	4051589001137
	080010-2-3	UVB 100 PE	3/54	4051589001236
	080010-3-3	UVB 100 L B	3/54	4051589001335
	080010-4-3	UVB 100 L S	3/54	4051589001434

For copper conductors (Cu)



NOMINAL VOLTAGE	NOMINAL CURRENT	STANDARDS
1000 V AC	101 A	EN 60998-2-1

Model	Part no.	Type	PU	GTIN / EAN
UVB 100 for copper conductors	080010-0-4	UVB 100 L G	3/54	4051589800105
	080010-1-4	UVB 100 N	3/54	4051589800112
	080010-2-4	UVB 100 PE	3/54	4051589800129
	080010-3-4	UVB 100 L B	3/54	4051589800136
	080010-4-4	UVB 100 L S	3/54	4051589800143

For aluminium and copper conductors (Al/Cu)



NOMINAL VOLTAGE	NOMINAL CURRENT	STANDARDS
1000 V AC / 1500 V DC	185 A Al	IEC 61238-1 (Class A)
1000 V AC / 1500 V DC	200 A Cu	IEC 60947-7-1

Model	Part no.	Type	PU	GTIN / EAN
UVB 200 for aluminium/ copper conductors	080030-0-3	UVB 200 L G	3/18	4051589003032
	080030-1-3	UVB 200 N	3/18	4051589003131
	080030-2-3	UVB 200 PE	3/18	4051589003230
	080030-3-3	UVB 200 L B	3/18	4051589003339
	080030-4-3	UVB 200 L S	3/18	4051589003438

For copper conductors (Cu)



NOMINAL VOLTAGE	NOMINAL CURRENT	STANDARDS
1000 V AC / 1500 V DC	200 A	IEC 60947-7-1

Model	Part no.	Type	PU	GTIN / EAN
UVB 200 for copper conductors	080030-0-4	UVB 200 L G	3/18	4051589800303
	080030-1-4	UVB 200 N	3/18	4051589800310
	080030-2-4	UVB 200 PE	3/18	4051589800327
	080030-3-4	UVB 200 L B	3/18	4051589800334
	080030-4-4	UVB 200 L S	3/18	4051589800341

Power loss UVB 100

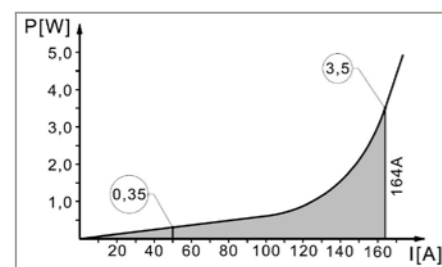

Dimensions:

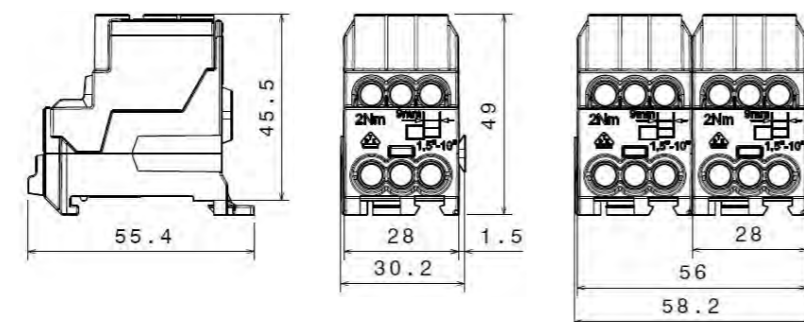

Dimensions:

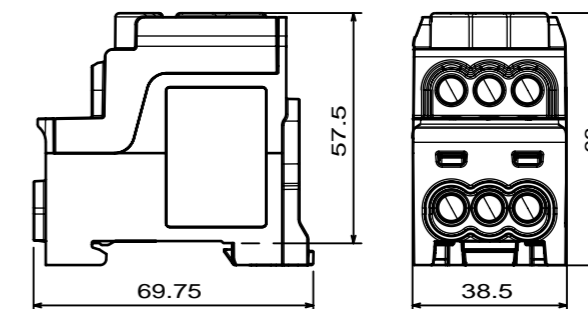



HLAK

MAIN LINE BRANCH TERMINALS (HLAK)

Cost efficiency, simplicity and safety

MAIN LINE BRANCH TERMINALS (HLAK)

Main line branch terminals are the first choice for connecting mains supply conductors. HORA eTec components are also suitable for use in other application areas, such as junction boxes. Main line branch terminals feature an optimized design, with the HORA eTec range covering both A and part-safe B designs as well as C designs that are finger-safe on all sides. These last designs have since come to dominate the field in electrical engineering solutions.

HORA eTec main line branch terminals benefit from huge savings in costs due to the optimized design in the brass body, and simplified screw mounting cuts installation times. Dome technology keeps screws attached to the plastic casing, preventing loss. No brake screws are needed, eliminating torque loss during installation. The rounded edges ensure a user-friendly design. The plastic casings are self-extinguishing and halogen-free. Identical design in every 25 mm² and 35 mm² main line branch terminal ensures free stacking and combination arrangements. All main line branch terminals can be horizontally and, in most cases, vertically mounted on TS 35 rails according to IEC 60715 / DIN EN 50022. The mature technology used is suitable for voltages up to 1.000V AC or DC.

The entire main line branch terminal range has been certified and approved according to IEC, VDE, UL, CSA and FI. All versions have also been subjected to independent power-loss testing at SGS Fimko. All C-versions of the HORA eTec main line branch terminals are approved for round or sector-shaped solid, stranded and flexible conductors in copper or aluminium; a specialised triple coating on the brass body makes this possible.

HORA eTec main line branch terminals are currently the narrowest on the market. The module width of 17.8 mm on 25 mm² main branch terminals saves lots of space and therefore huge costs. HORA eTec will optionally custom-label your main line branch terminals with your customer brand on request. Delivery in custom industrial packaging is also available. All main line branch terminals fulfil the EC Directive on the Restriction of Hazardous Substances in Electrical and Electronic Equipment (RoHS). Covers in the respective live, neutral, and earth colours are available.

Apart from the C-type models, HORA eTec supplies non-finger-proof A-type and the vertically finger-proof B-type main line branch terminals, each available in 25 mm², 35 mm²/25 mm² and 35 mm² versions. All the non-finger-safe main line branch terminals are available in single, double, four and five-pole versions.

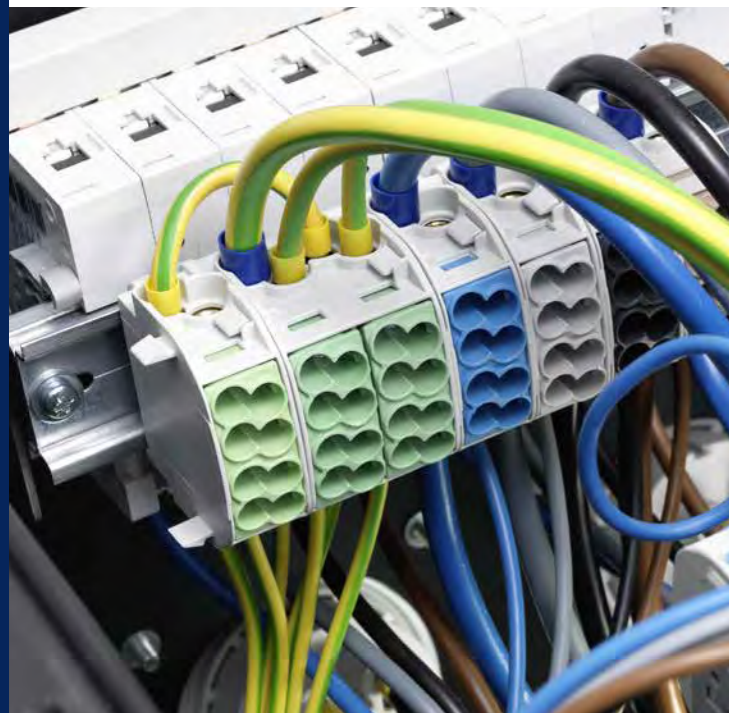

PRODUCT BENEFITS

- > Suitable for all round and sector-shaped solid, stranded or flexible conductors in copper or aluminium
- > Cost savings from optimized brass body, as well as extremely narrow and compact design with rounded corners
- > User-friendliness with simplified screw assembly, captive screws attached to the plastic casing, no brake screws needed
- > Horizontal and vertical installation
- > Self-extinguishing halogen-free plastic housing



HLAK

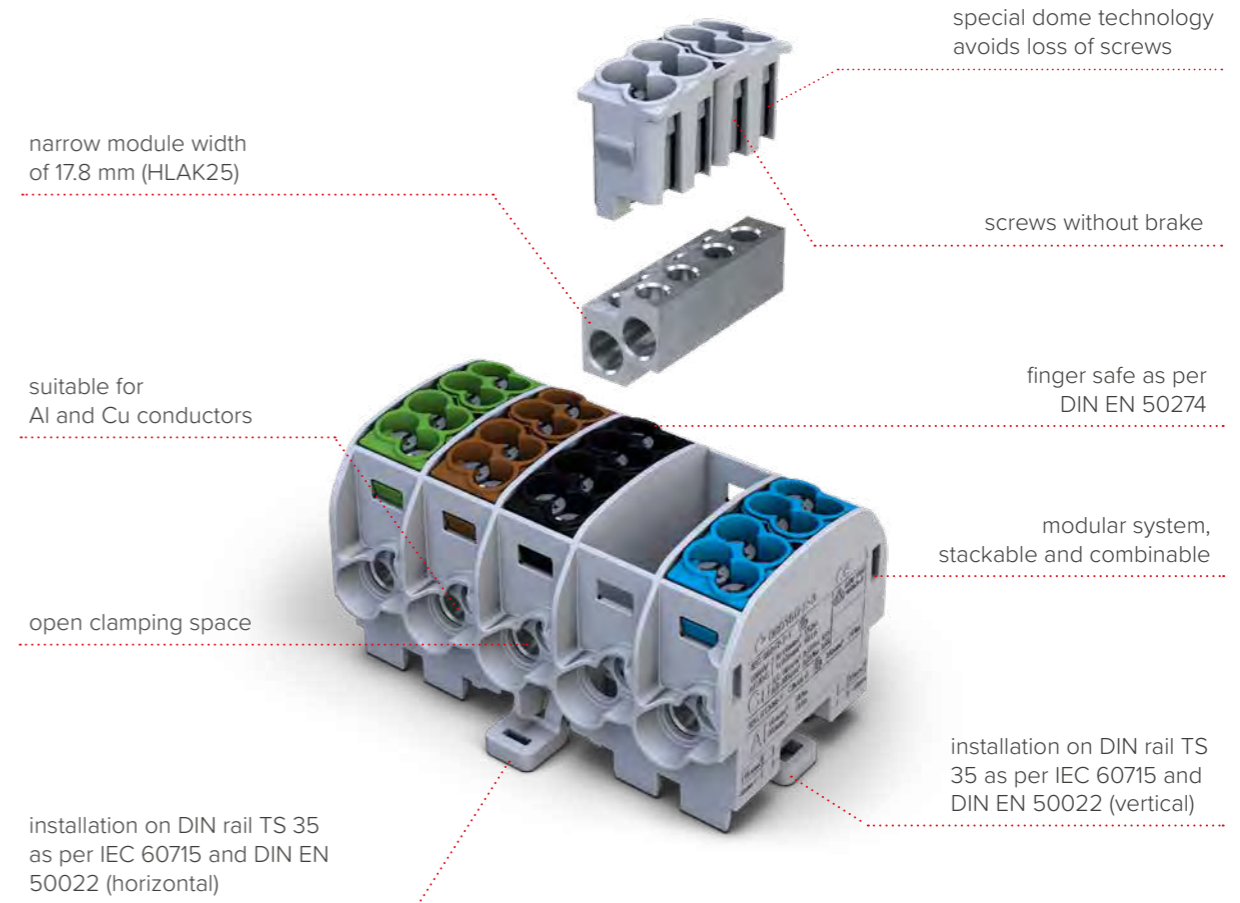

CERTIFICATES

- > IEC 60947-7-1
- > IEC 61238-1 (Class A)
- > UL-1059
- > CSA C22.2 No.158-10
- > DIN VDE 0603-2



CONFORMITY



SAFETY



MAIN LINE BRANCH TERMINALS (HLAK)

HLAK 25 TYPE C - 1 POLE



MAIN LINE

2 x 25 mm² - 2,5 mm² (4 - 14 AWG)
16 mm² - 1,5 mm² (6 - 16 AWG)



BRANCH LINE

2 x 16 mm² - 2,5 mm² (6 - 14 AWG)
10 mm² - 1,5 mm² (8 - 16 AWG)



- > modular system, module width 17,8 mm
- > user-defined stackable
- > to fit on DIN rail TS 35



AL/CU



HLAK 25D TYPE C - 1 POLE



MAIN LINE

4 x 25 mm² - 2,5 mm² (4 - 14 AWG)
16 mm² - 1,5 mm² (6 - 16 AWG)



BRANCH LINE

4 x 16 mm² - 2,5 mm² (6 - 14 AWG)
10 mm² - 1,5 mm² (8 - 16 AWG)



- > modular system
- > user-defined stackable
- > to fit on DIN rail TS 35



AL/CU



FOR ALUMINIUM AND COPPER CONDUCTORS (AL/CU)



NOMINAL VOLTAGE	NOMINAL CURRENT	STANDARDS
1000 V AC/DC	152 A Cu	IEC 60947-7-1
1000 V AC/DC	100 A Al	IEC 61238-1 (Class A)
600 V	90 A Cu / 70 A Al	UL-1059 / CSA C22.2 No.158-10

Model	Part No. *	Type	PU	GTIN / EAN
HLAK 25/16 for aluminium/ copper conductors	080110-0-3	HLAK 25/16 L G	5/60	4051589011037
	080110-1-3	HLAK 25/16 N	5/60	4051589011136
	080110-2-3	HLAK 25/16 PE	5/60	4051589011235
	080110-3-3	HLAK 25/16 L B	5/60	4051589011334
	080110-4-3	HLAK 25/16 L S	5/60	4051589011433

* Other colours available on request

FOR COPPER CONDUCTORS (CU)



NOMINAL VOLTAGE	NOMINAL CURRENT	STANDARDS
1000 V AC/DC	152 A	IEC 60947-7-1
690 V	100 A	DIN VDE 0603-2

Model	Part No. *	Type	PU	GTIN / EAN
HLAK 25/16 for copper conductors	080110-0-4	HLAK 25/16 L G	5/60	4051589801102
	080110-1-4	HLAK 25/16 N	5/60	4051589801119
	080110-2-4	HLAK 25/16 PE	5/60	4051589801126
	080110-3-4	HLAK 25/16 L B	5/60	4051589801133
	080110-4-4	HLAK 25/16 L S	5/60	4051589801140

* Other colours available on request

FOR ALUMINIUM AND COPPER CONDUCTORS (AL/CU)



NOMINAL VOLTAGE	NOMINAL CURRENT	STANDARDS
1000 V AC/DC	152 A Cu	IEC 60947-7-1
1000 V AC/DC	100 A Al	IEC 61238-1 (Class A)
600 V	90 A Cu / 70 A Al	UL-1059 / CSA C22.2 No.158-10

Model	Part No. *	Type	PU	GTIN / EAN
HLAK 25/16-D for aluminium/ copper conductors	080120-0-3	HLAK 25/16-D L G	2/36	4051589012034
	080120-1-3	HLAK 25/16-D N	2/36	4051589012133
	080120-2-3	HLAK 25/16-D PE	2/36	4051589012232
	080120-3-3	HLAK 25/16-D L B	2/36	4051589012331
	080120-4-3	HLAK 25/16-D S	2/36	4051589012430

* Other colours available on request

FOR COPPER CONDUCTORS (CU)



NOMINAL VOLTAGE	NOMINAL CURRENT	STANDARDS
1000 V AC/DC	152 A	IEC 60947-7-1
690 V	100 A	DIN VDE 0603-2

Model	Part No. *	Type	PU	GTIN / EAN
HLAK 25/16-D for copper conductors	080120-0-4	HLAK 25/16-D L G	2/36	4051589801201
	080120-1-4	HLAK 25/16-D N	2/36	4051589801218
	080120-2-4	HLAK 25/16-D PE	2/36	4051589801225
	080120-3-4	HLAK 25/16-D L B	2/36	4051589801232
	080120-4-4	HLAK 25/16-D L S	2/36	4051589801249

* Other colours available on request

Power loss HLAK 25/16

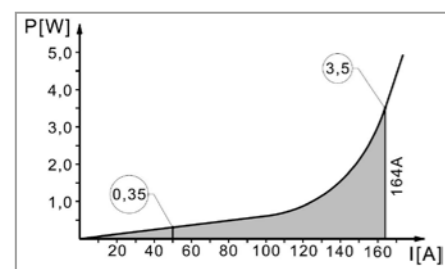

Dimensions:

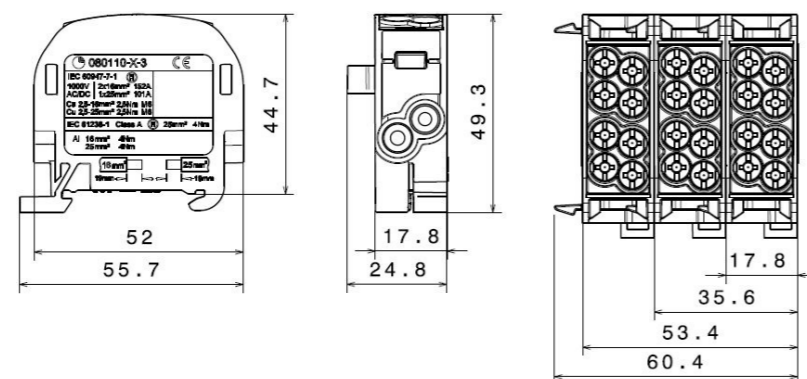

Power loss HLAK 25/16-D

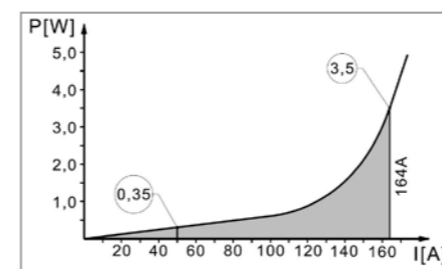

Dimensions:

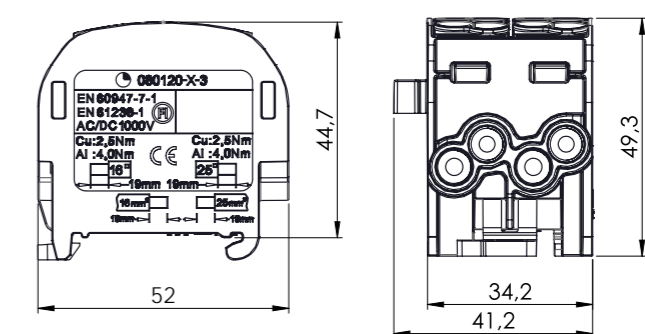

MAIN LINE BRANCH TERMINALS (HLAK)

HLAK 25 3/2 Type C - 3 pole



MAINLINE (PER POLE)		BRANCHLINE (PER POLE)	
2 x	25 mm ² - 2,5 mm ² (4 - 14 AWG)	2 x	16 mm ² - 2,5 mm ² (6 - 14 AWG)
	16 mm ² - 1,5 mm ² (6 - 16 AWG)		10 mm ² - 1,5 mm ² (8 - 16 AWG)

- > modular system, module width 17,8 mm
- > user-defined stackable
- > to fit on DIN rail TS 35



080130-0-X



080130-1-X



080130-5-X

AL / CU

For aluminium and copper conductors (Al/Cu)

NOMINAL VOLTAGE	NOMINAL CURRENT	STANDARDS
1000 V AC/DC	152 A Cu	IEC 60947-7-1
1000 V AC/DC	100 A Al	IEC 61238-1 (Class A)
600 V	90 A Cu / 70 A Al	UL-1059 / CSA C22.2 No.158-10

Model	Part No. *	Type	PU	GTIN / EAN
HLAK 25/16 for aluminium/ copper conductors	080130-0-3	HLAK 25/16 3/2 3L G	2/24	4051589013031
	080130-1-3	HLAK 25/16 3/2 L G/N/PE	2/24	4051589013130
	080130-5-3	HLAK 25/16 3/2 3L BSG	2/24	4051589013536

* Other colours/colour combinations available on request

For copper conductors (Cu)

NOMINAL VOLTAGE	NOMINAL CURRENT	STANDARDS
1000 V AC/DC	152 A	IEC 60947-7-1
690 V	100 A	DIN VDE 0603-2

Model	Part No. *	Type	PU	GTIN / EAN
HLAK 25/16 for copper conductors	080130-0-4	HLAK 25/16 3/2 3L G	2/24	4051589801300
	080130-1-4	HLAK 25/16 3/2 L G/N/PE	2/24	4051589801317
	080130-5-4	HLAK 25/16 3/2 3L BSG	2/24	4051589801355

* Other colours/colour combinations available on request

Power loss HLAk 25/16

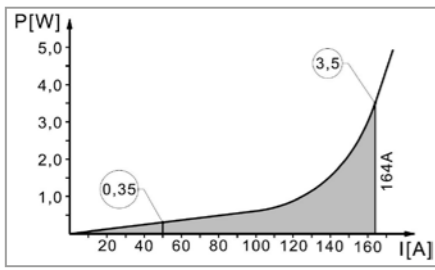

Dimensions:

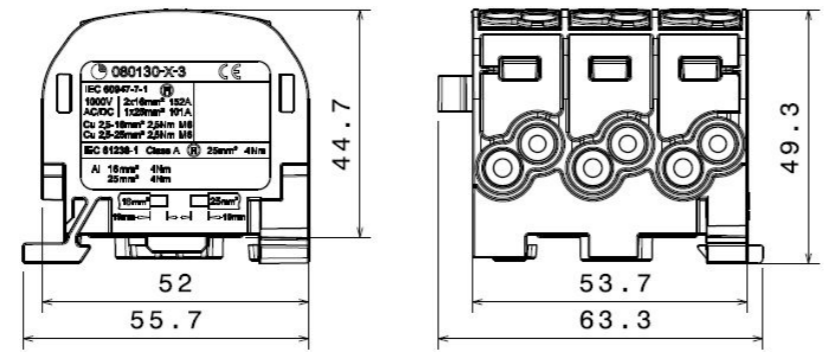

HLAK 25 Type C - 4 pole



MAIN LINE		BRANCH LINE	
2 x	25 mm ² - 2,5 mm ² (4 - 14 AWG)	2 x	16 mm ² - 2,5 mm ² (6 - 14 AWG)
	16 mm ² - 1,5 mm ² (6 - 16 AWG)		10 mm ² - 1,5 mm ² (8 - 16 AWG)

- > modular system, module width 17,8 mm
- > user-defined stackable
- > to fit on DIN rail TS 35



080140-0-X



080140-1-X



080140-5-X

AL / CU

For aluminium and copper conductors (Al/Cu)

NOMINAL VOLTAGE	NOMINAL CURRENT	STANDARDS
1000 V AC/DC	152 A Cu	IEC 60947-7-1
1000 V AC/DC	100 A Al	IEC 61238-1 (Class A)
600 V	90 A Cu / 70 A Al	UL-1059 / CSA C22.2 No.158-10

Model	Part No. *	Type	PU	GTIN / EAN
HLAK 25/16 for aluminium/ copper conductors	080140-0-3	HLAK 25/16 4L G	1/12	4051589014038
	080140-1-3	HLAK 25/16 3L G/N	1/12	4051589014137
	080140-5-3	HLAK 25/16 3L BSG/N	1/12	4051589014533

* Other colours/colour combinations available on request

For copper conductors (Cu)

NOMINAL VOLTAGE	NOMINAL CURRENT	STANDARDS
1000 V AC/DC	152 A	IEC 60947-7-1
690 V	100 A	DIN VDE 0603-2

Model	Part No. *	Type	PU	GTIN / EAN
HLAK 25/16 for copper conductors	080140-0-4	HLAK 25/16 4L G	1/12	4051589801409
	080140-1-4	HLAK 25/16 3L G/N	1/12	4051589801416
	080140-5-4	HLAK 25/16 3L BSG/N	1/12	4051589801454

* Other colours/colour combinations available on request

Power loss HLAk 25/16

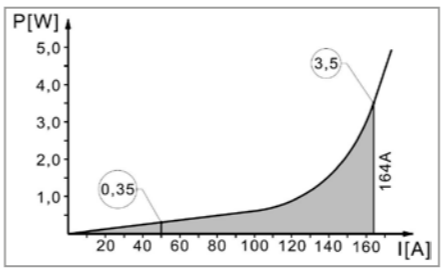

Dimensions:

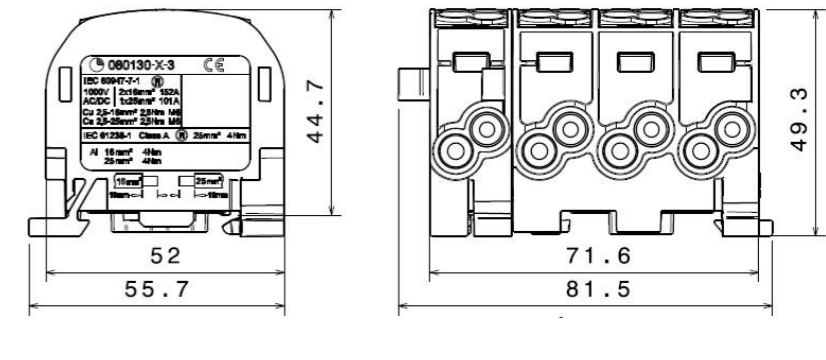

MAIN LINE BRANCH TERMINALS (HLAK)

HLAK 25 Type C - 5 pole



080150-0-X

MAINLINE (PER POLE)

2 x 25 mm² - 2,5 mm²
16 mm² - 1,5 mm²



BRANCHLINE (PER POLE)

2 x 16 mm² - 2,5 mm²
10 mm² - 1,5 mm²



- > modular system, module width 17,8 mm
- > user-defined stackable
- > to fit on DIN rail TS 35



080150-3-X



080150-5-X

AL / CU

HLAK 35 Type C - 1 pole



080210-0-X

MAIN LINE

2 x 35 mm² - 4 mm² (2 - 12 AWG)
25 mm² - 2,5 mm² (4 - 14 AWG)



BRANCH LINE

2 x 25 mm² - 2,5 mm² (4 - 14 AWG)
16 mm² - 1,5 mm² (6 - 16 AWG)



- > modular system
- > user-defined stackable
- > to fit on DIN rail TS 35



080210-1-X



080210-2-X



080210-3-X



080210-4-X



HLAK

AL / CU

For aluminium and copper conductors (Al/Cu)



NOMINAL VOLTAGE	NOMINAL CURRENT	STANDARDS
1000 V AC/DC	152 A Cu	IEC 60947-7-1
1000 V AC/DC	100 A Al	IEC 61238-1 (Class A)

Model	Part No. *	Type	PU	GTIN / EAN
HLAK 25/16 for aluminium/ copper conductors	080150-0-3	HLAK 25/16 5L G	1/12	4051589015035
	080150-1-3	HLAK 25/16 3L G/N/PE	1/12	4051589015134
	080150-3-3	HLAK 25/16 PE/3L G/N	1/12	4051589015332
	080150-5-3	HLAK 25/16 PE/3L BSG/N	1/12	4051589015530

* Other colours/colour combinations available on request

For aluminium and copper conductors (Al/Cu)



NOMINAL VOLTAGE	NOMINAL CURRENT	STANDARDS
1000 V AC/DC	202 A Cu	IEC 60947-7-1
1000 V AC/DC	125 A Al	IEC 61238-1 (Class A)
600 V	125 A Cu / 100 A Al	UL-1059 / CSA C22.2 No.158-10

Model	Part No. *	Type	PU	GTIN / EAN
HLAK 35/25 for aluminium/ copper conductors	080210-0-3	HLAK 35/25 L G	5/60	4051589021036
	080210-1-3	HLAK 35/25 N	5/60	4051589021135
	080210-2-3	HLAK 35/25 PE	5/60	4051589021234
	080210-3-3	HLAK 35/25 L B	5/60	4051589021333
	080210-4-3	HLAK 35/25 L S	5/60	4051589021432

* Other colours available on request

For copper conductors (Cu)



NOMINAL VOLTAGE	NOMINAL CURRENT	STANDARDS
1000 V AC/DC	152 A	IEC 60947-7-1
690 V	100 A	DIN VDE 0603-2

Model	Part No. *	Type	PU	GTIN / EAN
HLAK 25/16 for copper conductors	080150-0-4	HLAK 25/16 5L G	1/12	4051589801508
	080150-1-4	HLAK 25/16 3L G/N/PE	1/12	4051589801515
	080150-3-4	HLAK 25/16 PE/3L G/N	1/12	4051589801539
	080150-5-4	HLAK 25/16 PE/3L BSG/N	1/12	4051589801553

* Other colours/colour combinations available on request

For copper conductors (Cu)



NOMINAL VOLTAGE	NOMINAL CURRENT	STANDARDS
1000 V AC/DC	202 A	IEC 60947-7-1
690 V	125 A	DIN VDE 0603-2

Model	Part No. *	Type	PU	GTIN / EAN
HLAK 35/25 for copper conductors	080210-0-4	HLAK 35/25 L G	5/60	4051589802109
	080210-1-4	HLAK 35/25 N	5/60	4051589802116
	080210-2-4	HLAK 35/25 PE	5/60	4051589802123
	080210-3-4	HLAK 35/25 L B	5/60	4051589802130
	080210-4-4	HLAK 35/25 L S	5/60	4051589802147

* Other colours available on request

Power loss HLAk 25/16

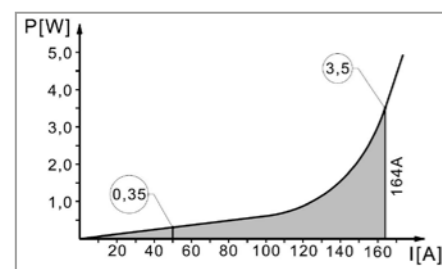

Dimensions:

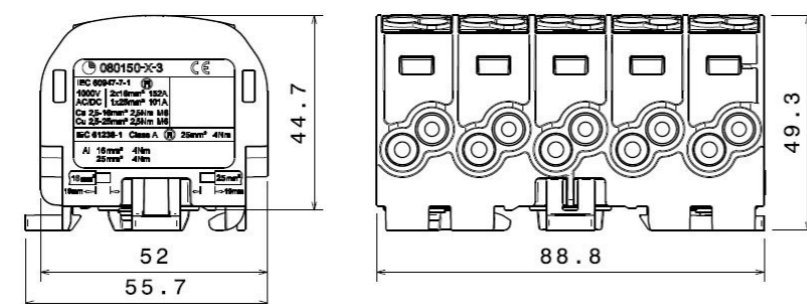

Power loss HLAk 35/25

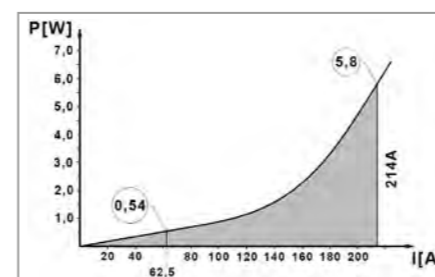

Dimensions:

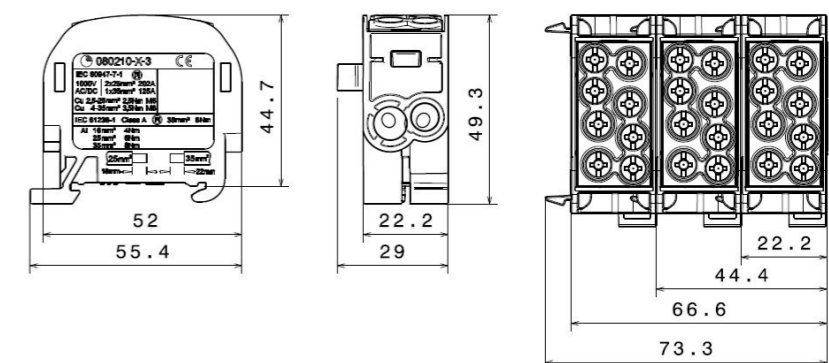

MAIN LINE BRANCH TERMINALS (HLAK)

HLAK 35D Type C - 1 pole



080220-0-X

MAIN LINE

4 x 35 mm² - 4 mm²
25 mm² - 2,5 mm²



BRANCH LINE

4 x 25 mm² - 2,5 mm²
16 mm² - 1,5 mm²



- > modular system
- > user-defined stackable
- > to fit on DIN rail TS 35



AL / CU



080220-1-X



080220-2-X



080220-3-X



080220-4-X

HLAK 35 Type C - 3 pole



080230-0-X

MAINLINE (PER POLE)

2 x 35 mm² - 4 mm²
25 mm² - 2,5 mm²



BRANCHLINE (PER POLE)

2 x 25 mm² - 2,5 mm²
16 mm² - 1,5 mm²



- > modular system
- > user-defined stackable
- > to fit on DIN rail TS 35



AL / CU



080230-1-X



080230-5-X



HLAK

For aluminium and copper conductors (Al/Cu)



NOMINAL VOLTAGE	NOMINAL CURRENT	STANDARDS
1000 V AC/DC	428 A Cu	IEC 60947-7-1
1000 V AC/DC	125 A Al	IEC 61238-1 (Class A)

Model	Part No. *	Type	PU	GTIN / EAN
HLAK 35/25-D for aluminium/ copper conductors	080220-0-3	HLAK 35/25-D L G	2/24	4051589022033
	080220-1-3	HLAK 35/25-D N	2/24	4051589022132
	080220-2-3	HLAK 35/25-D PE	2/24	4051589022231
	080220-3-3	HLAK 35/25-D L B	2/24	4051589022330
	080220-4-3	HLAK 35/25-D L S	2/24	4051589022439

* Other colours available on request

For copper conductors (Cu)



NOMINAL VOLTAGE	NOMINAL CURRENT	STANDARDS
1000 V AC/DC	428 A	IEC 60947-7-1
690 V	125 A	DIN VDE 0603-2

Model	Part No. *	Type	PU	GTIN / EAN
HLAK 35/25-D for copper conductors	080220-0-4	HLAK 35/25-D L G	2/24	4051589802208
	080220-1-4	HLAK 35/25-D N	2/24	4051589802215
	080220-2-4	HLAK 35/25-D PE	2/24	4051589802222
	080220-3-4	HLAK 35/25-D L B	2/24	4051589802239
	080220-4-4	HLAK 35/25-D L S	2/24	4051589802246

* Other colours available on request

For aluminium and copper conductors (Al/Cu)



NOMINAL VOLTAGE	NOMINAL CURRENT	STANDARDS
1000 V AC/DC	202 A Cu	IEC 60947-7-1
1000 V AC/DC	125 A Al	IEC 61238-1 (Class A)

Model	Part No. *	Type	PU	GTIN / EAN
HLAK 35/25 for aluminium/ copper conductors	080230-0-3	HLAK 35/25 3L G	2/24	4051589023030
	080230-1-3	HLAK 35/25 L G/N/PE	2/24	4051589023139
	080230-5-3	HLAK 35/25 3L BSG	2/24	4051589023535

* Other colours/colour combinations available on request

For copper conductors (Cu)



NOMINAL VOLTAGE	NOMINAL CURRENT	STANDARDS
1000 V AC/DC	202 A	IEC 60947-7-1
690 V	125 A	DIN VDE 0603-2

Model	Part No. *	Type	PU	GTIN / EAN
HLAK 35/25 for copper conductors	080230-0-4	HLAK 35/25 3L G	2/24	4051589802307
	080230-1-4	HLAK 35/25 L G/N/PE	2/24	4051589802314
	080230-5-4	HLAK 35/25 3L BSG	2/24	4051589802352

* Other colours/colour combinations available on request

Power loss HLAK 35/25-D

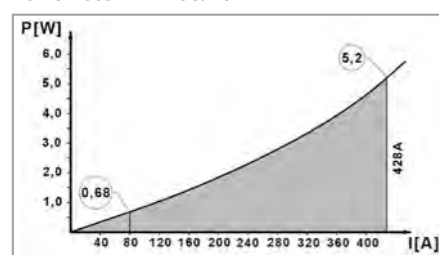

Dimensions:

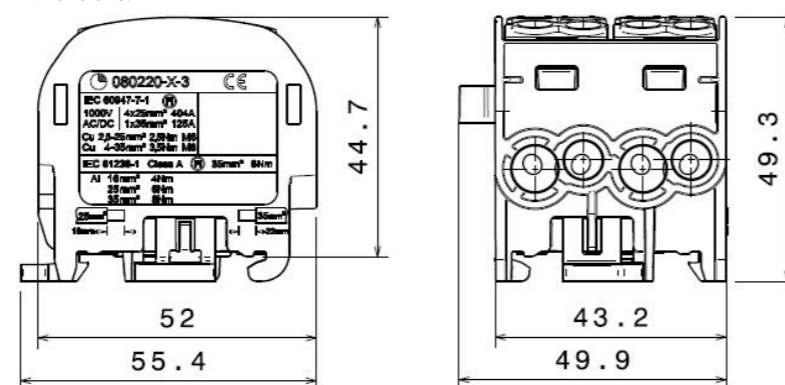

Power loss HLAK 35/25

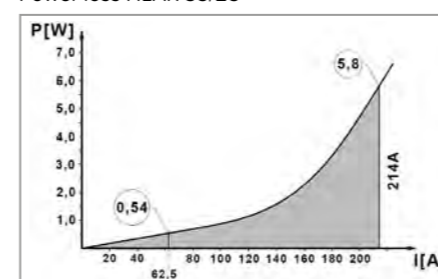

Dimensions:

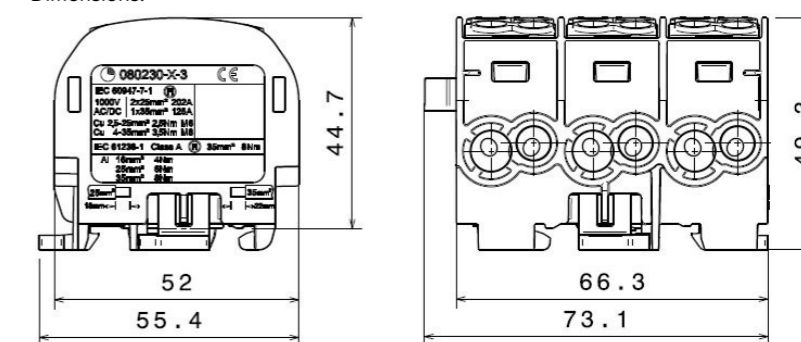

MAIN LINE BRANCH TERMINALS (HLAK)

HLAK 35 Type C - 4 pole



080240-0-X

MAINLINE (PER POLE)		BRANCHLINE (PER POLE)	
2 x	35 mm ² - 4 mm ² 25 mm ² - 2,5 mm ²	2 x	25 mm ² - 2,5 mm ² 16 mm ² - 1,5 mm ²

- > modular system
- > user-defined stackable
- > to fit on DIN rail TS 35



AL / CU



080240-1-X



080240-5-X

For aluminium and copper conductors (Al/Cu)

NOMINAL VOLTAGE	NOMINAL CURRENT	STANDARDS
1000 V AC/DC	202 A Cu	IEC 60947-7-1
1000 V AC/DC	125 A Al	IEC 61238-1 (Class A)

Model	Part No. *	Type	PU	GTIN / EAN
HLAK 35/25 for aluminium/ copper conductors	080240-0-3	HLAK 35/25 4L G	1/12	4051589024037
	080240-1-3	HLAK 35/25 3L G/N	1/12	4051589024136
	080240-5-3	HLAK 35/25 3L BSG/N	1/12	4051589024532

* Other colours/colour combinations available on request

For copper conductors (Cu)

NOMINAL VOLTAGE	NOMINAL CURRENT	STANDARDS
1000 V AC/DC	202 A	IEC 60947-7-1
690 V	125 A	DIN VDE 0603-2

Model	Part No. *	Type	PU	GTIN / EAN
HLAK 35/25 for copper conductors	080240-0-4	HLAK 35/25 4L G	1/12	4051589802406
	080240-1-4	HLAK 35/25 3L G/N	1/12	4051589802413
	080240-5-4	HLAK 35/25 3L BSG/N	1/12	4051589802451

* Other colours/colour combinations available on request

Power loss HLAk 35/25

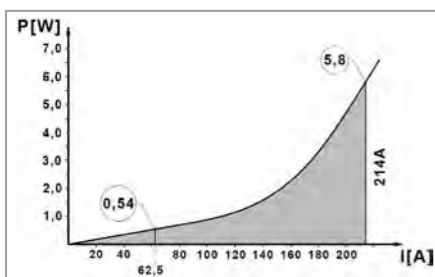

Dimensions:

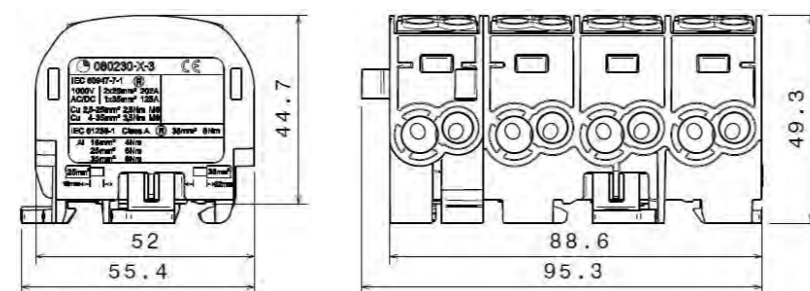

HLAK 35 Type C - 5 pole



080250-0-X

MAINLINE (PER POLE)		BRANCHLINE (PER POLE)	
2 x	35 mm ² - 4 mm ² 25 mm ² - 2,5 mm ²	2 x	25 mm ² - 2,5 mm ² 16 mm ² - 1,5 mm ²

- > modular system
- > user-defined stackable
- > to fit on DIN rail TS 35



AL / CU



080250-3-X



080250-5-X



HLAK

For aluminium and copper conductors (Al/Cu)

NOMINAL VOLTAGE	NOMINAL CURRENT	STANDARDS
1000 V AC/DC	202 A Cu	IEC 60947-7-1
1000 V AC/DC	125 A Al	IEC 61238-1 (Class A)

Model	Part No. *	Type	PU	GTIN / EAN
HLAK 35/25 for aluminium/ copper conductors	080250-0-3	HLAK 35/25 5L G	1/12	4051589025034
	080250-3-3	HLAK 35/25 PE/3L G/N	1/12	4051589025331
	080250-5-3	HLAK 35/25 PE/3L BSG/N	1/12	4051589025539

* Other colours/colour combinations available on request

For copper conductors (Cu)

NOMINAL VOLTAGE	NOMINAL CURRENT	STANDARDS
1000 V AC/DC	202 A	IEC 60947-7-1
690 V	125 A	DIN VDE 0603-2

Model	Part No. *	Type	PU	GTIN / EAN
HLAK 35/25 for copper conductors	080250-0-4	HLAK 35/25 5L G	1/12	4051589802505
	080250-3-4	HLAK 35/25 PE/3L G/N	1/12	4051589802536
	080250-5-4	HLAK 35/25 PE/3L BSG/N	1/12	4051589802550

* Other colours/colour combinations available on request

Power loss HLAk 35/25

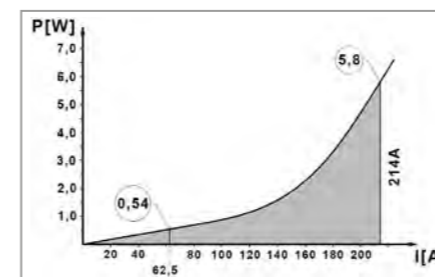

Dimensions:

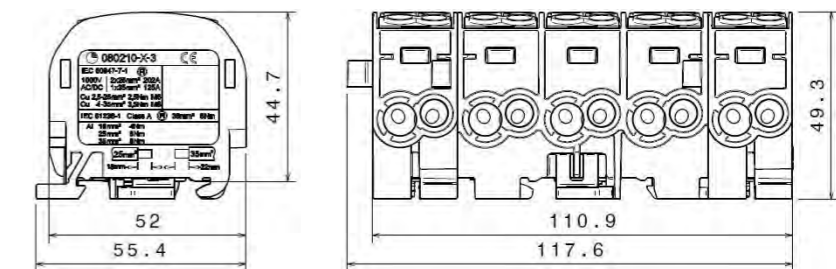

MAIN LINE BRANCH TERMINALS (HLAK)

HLAK 70 Type C - 1 pole



080310-0-X

MAIN LINE

2 x 70 mm² - 10 mm² (2/0 - 8 AWG)
 50 mm² - 6 mm² (1/0 - 10 AWG)



BRANCH LINE

2 x 50 mm² - 6 mm² (1/0 - 10 AWG)
 35 mm² - 4 mm² (2 - 12 AWG)



- > modular system
- > user-defined stackable
- > to fit on DIN rail TS 35



AL / CU



080310-1-X



080310-2-X



080310-3-X



080310-4-X

For aluminium and copper conductors (Al/Cu)



NOMINAL VOLTAGE	NOMINAL CURRENT	STANDARDS
1000 V AC/DC	300 A Cu	IEC 60947-7-1
1000 V AC/DC	185 A Al	IEC 61238-1 (Class A)
600 V	160 A Cu / 120 A Al	UL-1059 / CSA C22.2 No.158-10

Model	Part No. *	Type	PU	GTIN / EAN
HLAK 70/50 for aluminium/ copper conductors	080310-0-3	HLAK 70/50 L G	3/36	4051589031035
	080310-1-3	HLAK 70/50 N	3/36	4051589031134
	080310-2-3	HLAK 70/50 PE	3/36	4051589031233
	080310-3-3	HLAK 70/50 L B	3/36	4051589031332
	080310-4-3	HLAK 70/50 L S	3/36	4051589031431

* Other colours available on request

For copper conductors (Cu)



NOMINAL VOLTAGE	NOMINAL CURRENT	STANDARDS
1000 V AC/DC	300 A	IEC 60947-7-1
690 V	160 A	DIN VDE 0603-2

Model	Part No. *	Type	PU	GTIN / EAN
HLAK 70/50 for copper conductors	080310-0-4	HLAK 70/50 L G	3/36	4051589803106
	080310-1-4	HLAK 70/50 N	3/36	4051589803113
	080310-2-4	HLAK 70/50 PE	3/36	4051589803120
	080310-3-4	HLAK 70/50 L B	3/36	4051589803137
	080310-4-4	HLAK 70/50 L S	3/36	4051589803144

* Other colours available on request

Power loss HLAK 70/50

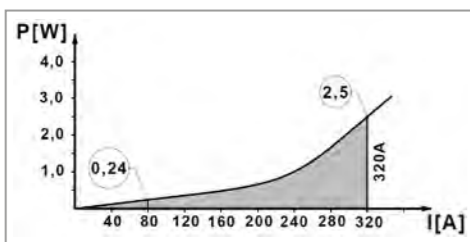

Dimensions:

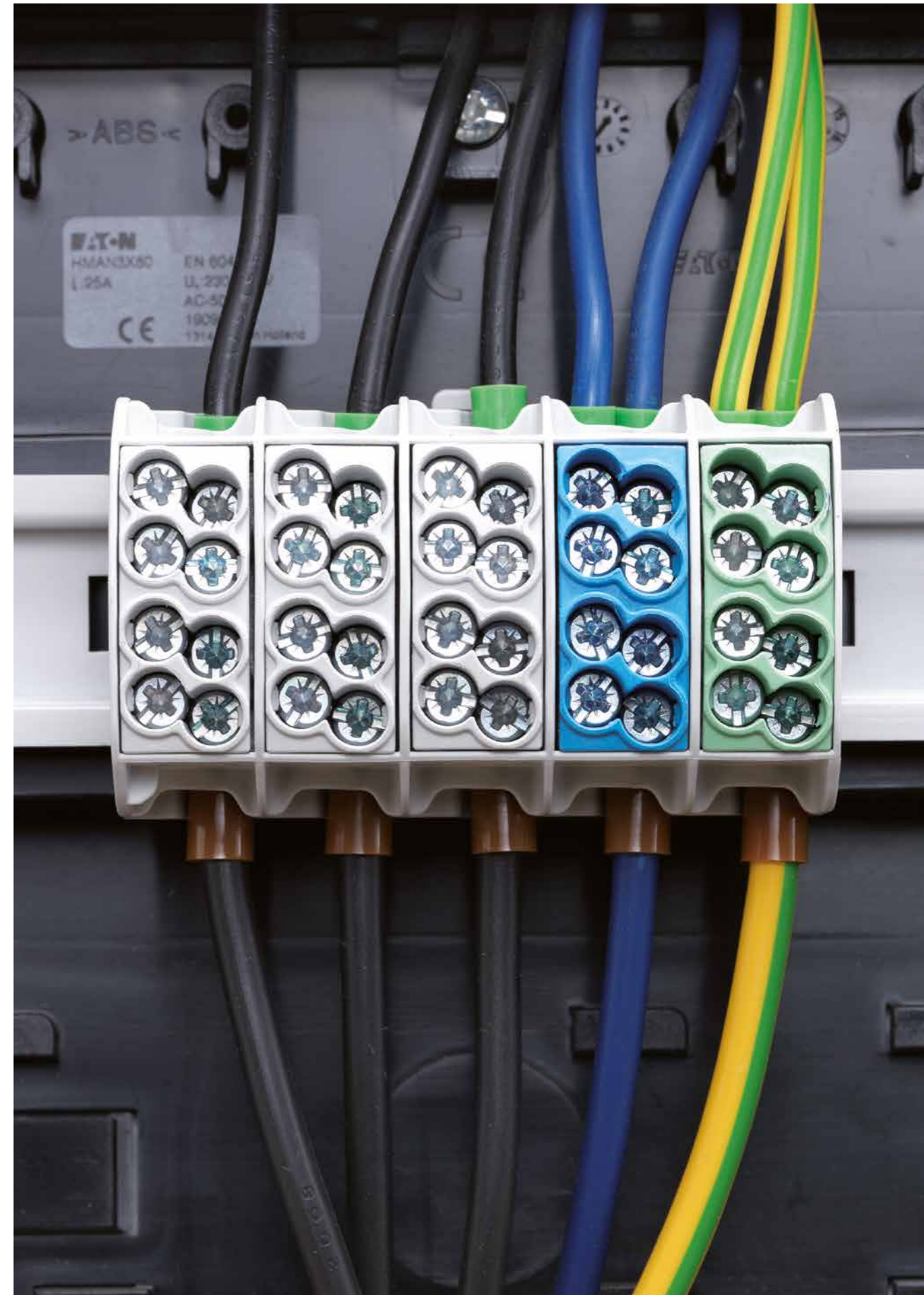
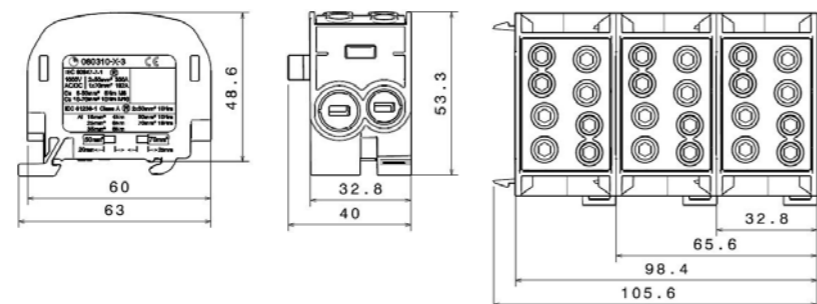

HLAK

MAIN LINE BRANCH TERMINALS (HLAK)

HLAK 25 TYPE A - 1 POLE



MAIN LINE (PER POLE)		BRANCH LINE (PER POLE)	
25 mm ² - 2,5 mm ²		16 mm ² - 2,5 mm ²	
16 mm ² - 1,5 mm ²		10 mm ² - 1,5 mm ²	

- > outgoing terminals on both sides
- > "open" incoming terminal due to slidetechnology
- > to fit on DIN rail TS 35

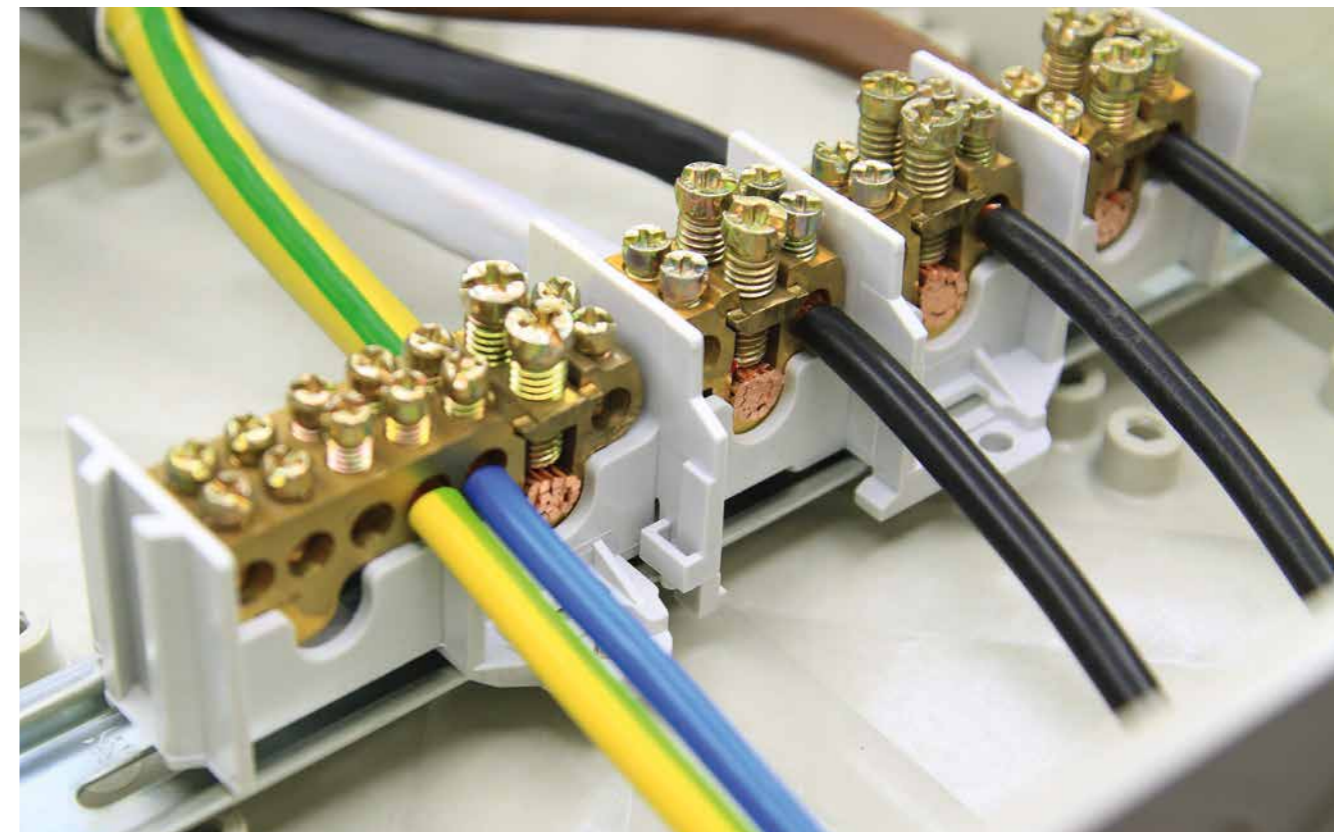
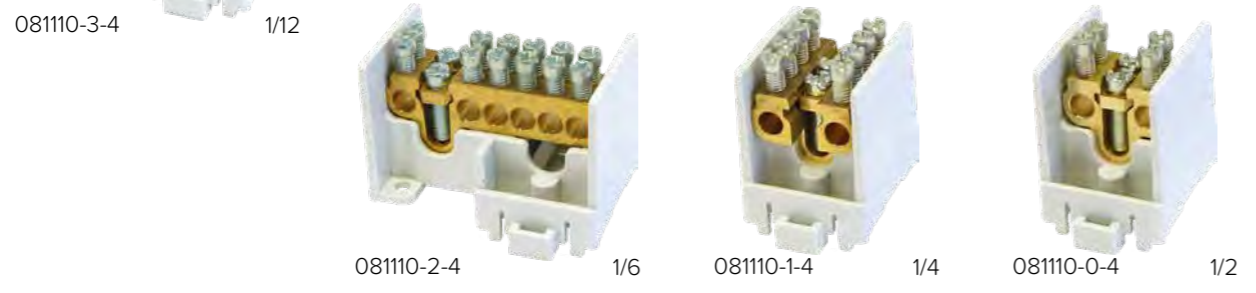

2 POLE



4 POLE

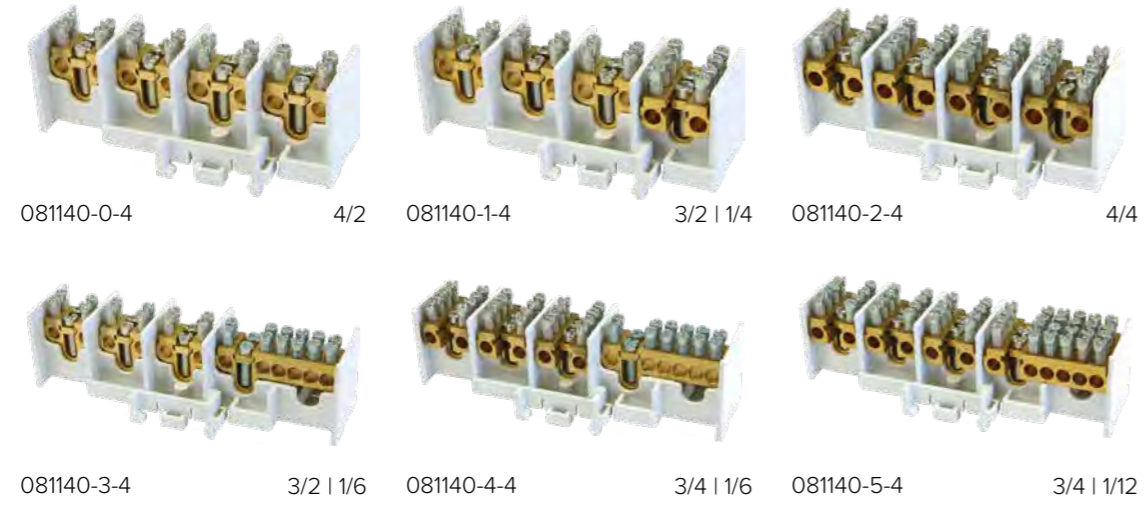

5 POLE

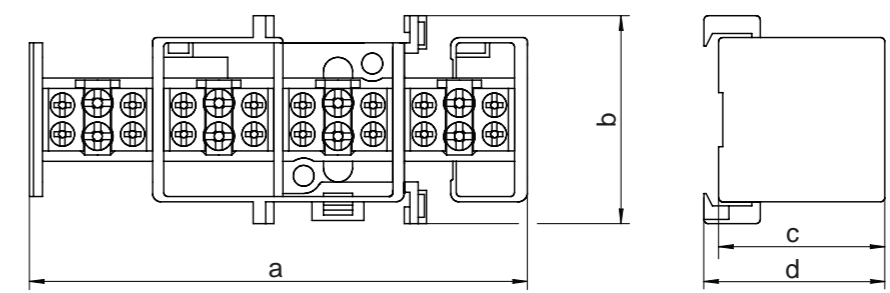

For copper conductors (Cu) CE

NOMINAL VOLTAGE		NOMINAL CURRENT		STANDARDS				
500 V		80 A		as per DIN VDE 0603-2				
Part No.	Pole No.	Inserts/Outgoings*	a	b	c	d	PU	GTIN /EAN
081110-0-4	1	1 / 2	32,5	50	40	46	20	4051589811101
081110-1-4	1	1 / 4	32,5	50	40	46	20	4051589811118
081110-2-4	1	1 / 6	62	50	40	46	10	4051589811125
081110-3-4	1	1 / 12	62	50	40	46	10	4051589811132
081120-0-4	2	2 / 2	62	50	40	46	10	4051589811200
081120-1-4	2	2 / 4	62	50	40	46	10	4051589811217
081140-0-4	4	4 / 2	121	50	40	46	10	4051589811408
081140-1-4	4	3 / 2 1 / 4	121	50	40	46	10	4051589811415
081140-2-4	4	4 / 4	121	50	40	46	10	4051589811422
081140-3-4	4	3 / 2 1 / 6	150,5	50	40	46	10	4051589811439
081140-4-4	4	3 / 4 1 / 6	150,5	50	40	46	10	4051589811446
081140-5-4	4	3 / 4 1 / 12	150,5	50	40	46	10	4051589811453
081150-0-4	5	5 / 2	150,5	50	40	46	10	4051589811507
081150-1-4	5	5 / 4	150,5	50	40	46	10	4051589811514

*Example: 3/4 | 1/12 = 3 Inserts / 4 Outgoings | 1 Insert / 12 Outgoings

MAIN LINE BRANCH TERMINALS (HLAK)

HLAK 35/25 TYPE A - 1 POLE



081210-1-4 1/4

MAIN LINE (PER POLE)		BRANCH LINE (PER POLE)	
35 mm ² - 4 mm ²		25 mm ² - 2,5 mm ²	
25 mm ² - 2,5 mm ²		16 mm ² - 1,5 mm ²	

- > modular system, module width 17,8 mm
- > user-defined stackable
- > to fit on DIN rail TS 35



081210-0-4 1/2

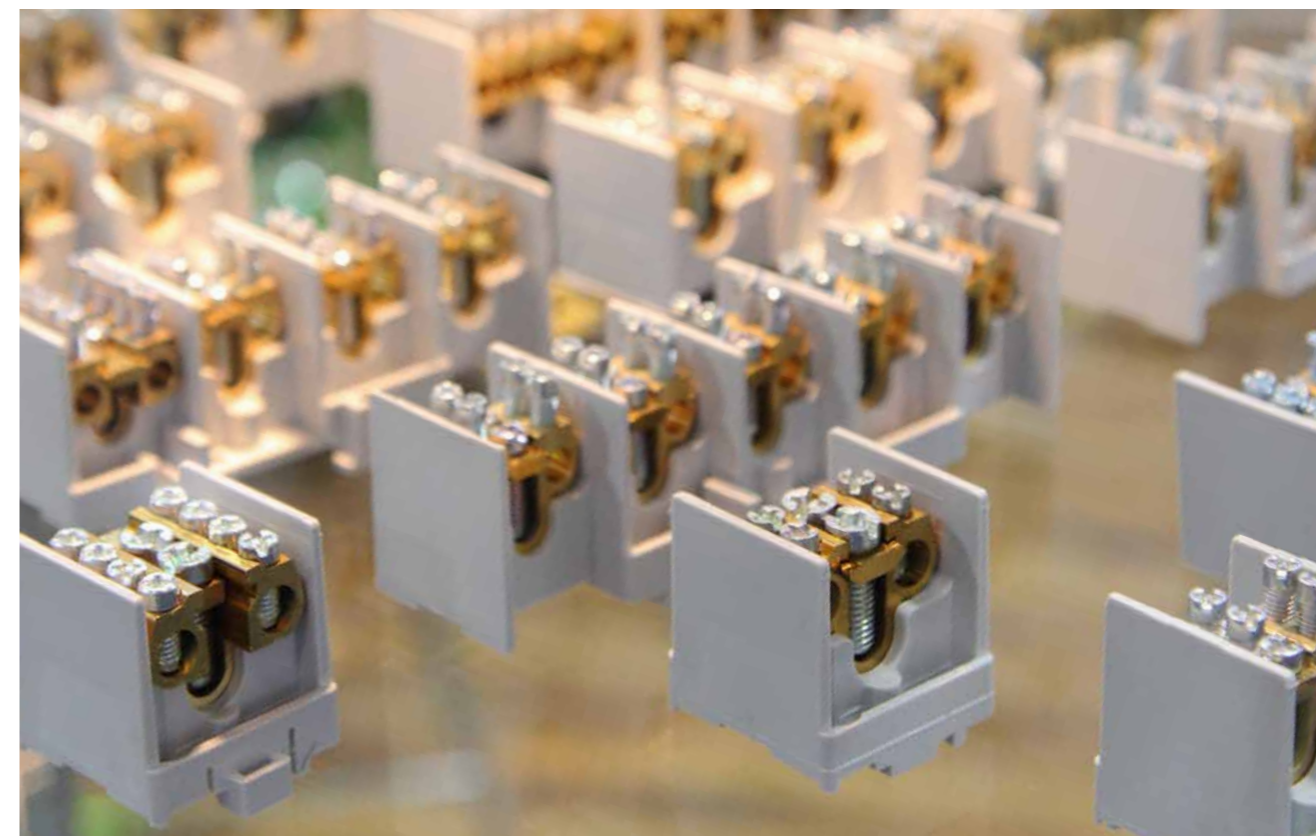

HLAK

2 POLE



081220-0-4 2/2



081220-1-4 2/4

4 POLE



081240-0-4 4/2



081240-1-4 3/2 | 1/6



081240-2-4 3/4 | 1/6



081240-3-4 3/2 | 1/4



081240-4-4 4/4

5 POLE



081250-0-4 5/2



081250-1-4 5/4

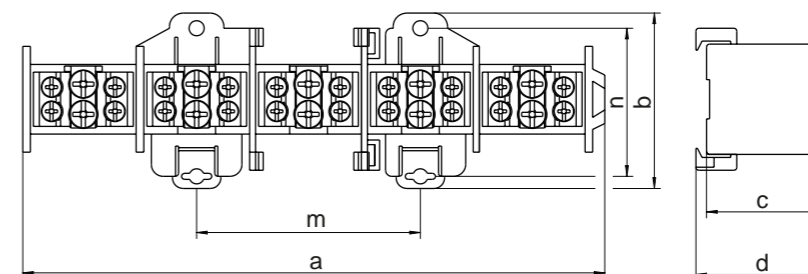

For copper conductors (Cu) CE

NOMINAL VOLTAGE		NOMINAL CURRENT		STANDARDS						
500 V		100 A		as per DIN VDE 0603-2						
Part No.	Pole No.	Inserts/Outgoings*	a	b	c	d	m	n	PU	GTIN /EAN
081210-0-4	1	1 / 2	40	44	40	44			20	4051589812108
081210-1-4	1	1 / 4	40	44	40	44			20	4051589812115
081220-0-4	2	2 / 2	77	44	40	44			10	4051589812207
081220-1-4	2	2 / 4	77	44	40	44			10	4051589812214
081240-0-4	4	4 / 2	154,5	60	40	46	74	48	1	4051589812405
081240-1-4	4	3 / 2 1 / 6	192	60	40	46	74	48	1	4051589812412
081240-2-4	4	3 / 4 1 / 6	192	60	40	46	74	48	1	4051589812429
081240-3-4	4	3 / 2 1 / 4	154,5	60	40	46	74	48	1	4051589812436
081240-4-4	4	4 / 4	154,5	60	40	46	74	48	1	4051589812443
081250-0-4	5	5 / 2	192	60	40	46	74	48	1	4051589812504
081250-1-4	5	5 / 4	192	60	40	46	74	48	1	4051589812511

*Example: 3/4 | 1/12 = 3 Inserts / 4 Outgoings | 1 Insert / 12 Outgoings

MAIN LINE BRANCH TERMINALS (HLAK)

HLAK 35/35 TYPE A - 1 POLE



081310-1-4 1/4

MAIN LINE (PER POLE)		BRANCH LINE (PER POLE)	
35 mm ² - 4 mm ²		35 mm ² - 4 mm ²	
25 mm ² - 2,5 mm ²		25 mm ² - 2,5 mm ²	

- > modular system, module width 17,8 mm
- > user-defined stackable
- > to fit on DIN rail TS 35



081310-0-4 1/2

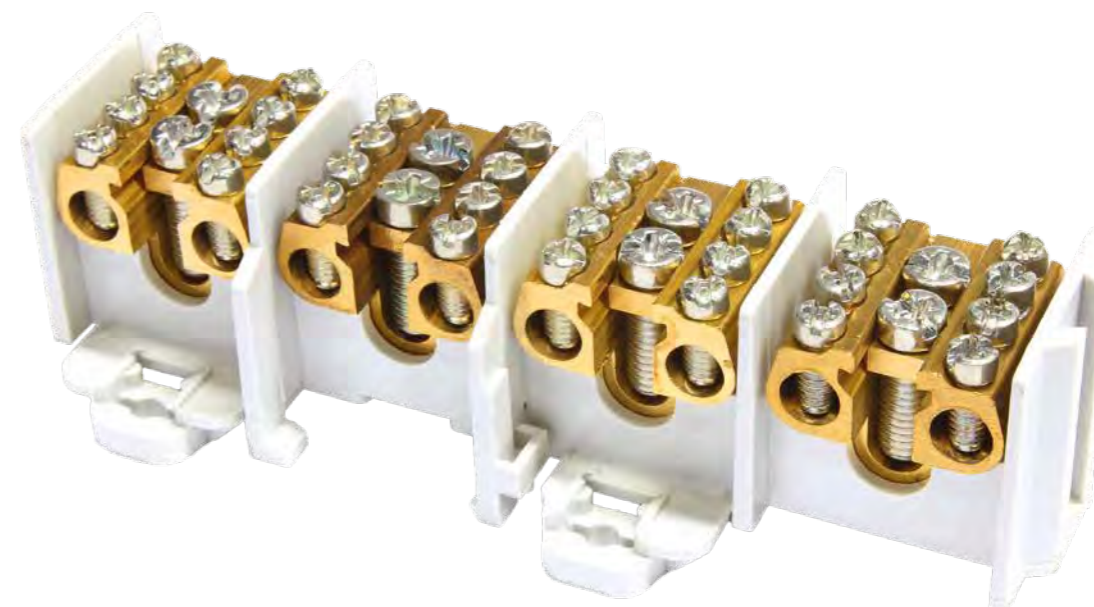

HLAK

2 POLE



081320-1-4

2/2



081320-0-4

2/4

4 POLE



081340-0-4

4/2



081340-1-4

4/4

5 POLE



081350-0-4

5/2



081350-1-4

5/4

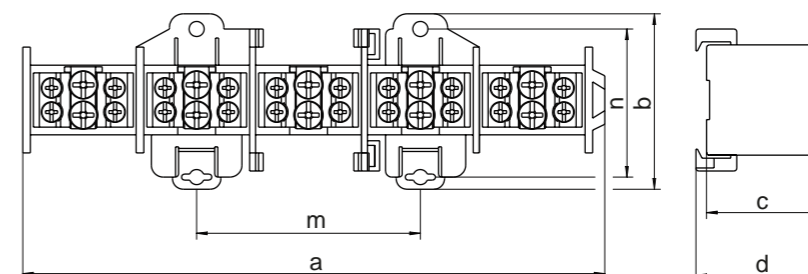

For copper conductors (Cu) CE

NOMINAL VOLTAGE	NOMINAL CURRENT	STANDARDS
500 V	100 A	as per DIN VDE 0603-2

Part No.	Pole No.	Inserts/Outgoings*	a	b	c	d	m	n	PU	GTIN /EAN
081310-0-4	1	1 / 2	40	44	40	44			20	4051589813105
081310-1-4	1	1 / 4	40	44	40	44			20	4051589813112
081320-1-4	2	2 / 2	77	44	40	44			10	4051589813211
081320-0-4	2	2 / 4	77	44	40	44			10	4051589813204
081340-0-4	4	4 / 2	154,5	60	40	46	74	48	1	4051589813402
081340-1-4	4	4 / 4	154,5	60	40	46	74	48	1	4051589813419
081350-0-4	5	5 / 2	192	60	40	46	74	48	1	4051589813501
081350-1-4	5	5 / 4	192	60	40	46	74	48	1	4051589813518

*Example: 3/4 | 1/2 = 3 Inserts / 4 Outgoings | 1 Insert / 2 Outgoings



TERMINAL BLOCKS (RKA)

Large cross sections
for a variety of applications

TERMINAL BLOCKS (RKA)

The HORA eTec RKA series of aluminium terminal blocks covers a wide variety of applications. Mechanical engineering, industrial equipment, automation, wind turbines, solar energy or other electrical engineering switchgear – HORA eTec terminal blocks are a highly versatile solution. A multitude of features presents major benefits in connection technology. All HORA eTec aluminium terminal blocks are of course finger-safe on all sides according to DIN EN 50274.

Unlike other product families from HORA eTec, the terminal blocks have aluminium bodies. A special coating ensures that the terminals are not only suitable for aluminium conductors, but also copper conductors. HORA eTec terminal blocks have worldwide approval for conductors in either material. An added benefit can be found in the substantially lower weight of HORA eTec terminal blocks due to the aluminium body, compared to more conventional terminal blocks. HORA eTec has focused on relatively large cross-sections to make it far easier to connect large cables; conductor cross-sections of up to 300 mm² are supported in various versions.

There is a certain reason for these relatively large cross-sections: whether round or sector-shaped, solid, stranded or flexible conductors, the added space allows all these cables to be installed. HORA eTec terminal blocks not only allow conductor connections, but are also perfectly capable of power distribution. The HORA eTec RKA series is very user-friendly mainly due to the compact, space-saving and robust nature of these terminal blocks. All types can be mounted on mounting plates or TS 35 rails according to IEC 60715 / DIN EN 50022.

All terminal blocks have push-through protection throughout to keep conductors from touching in the middle, and possibly oxidising. The screws have hex heads allowing the constant high torque required while installing the conductors using an Allen key. The turned screw ends prevent damage to the relatively soft aluminium conductor material on installation. The body and the plastic housing are designed to ensure effective heat dissipation while in use.

All versions integrate measurement connection as standard in all RKA 95 models at sizes 95 mm² and above, and are therefore optimized for power supply or monitoring connections for uninterrupted monitoring in HORA eTec terminal blocks without disconnecting previously connected supply conductors.

The accessories also make installation easier – dust covers keep unwanted particles out, and have breakouts for the required conductor sizes. Users may label the terminal blocks with the respective RAL colours for live, earth and neutral. Unique labels with clips for identifying connections for different conductors round off the accessory range.

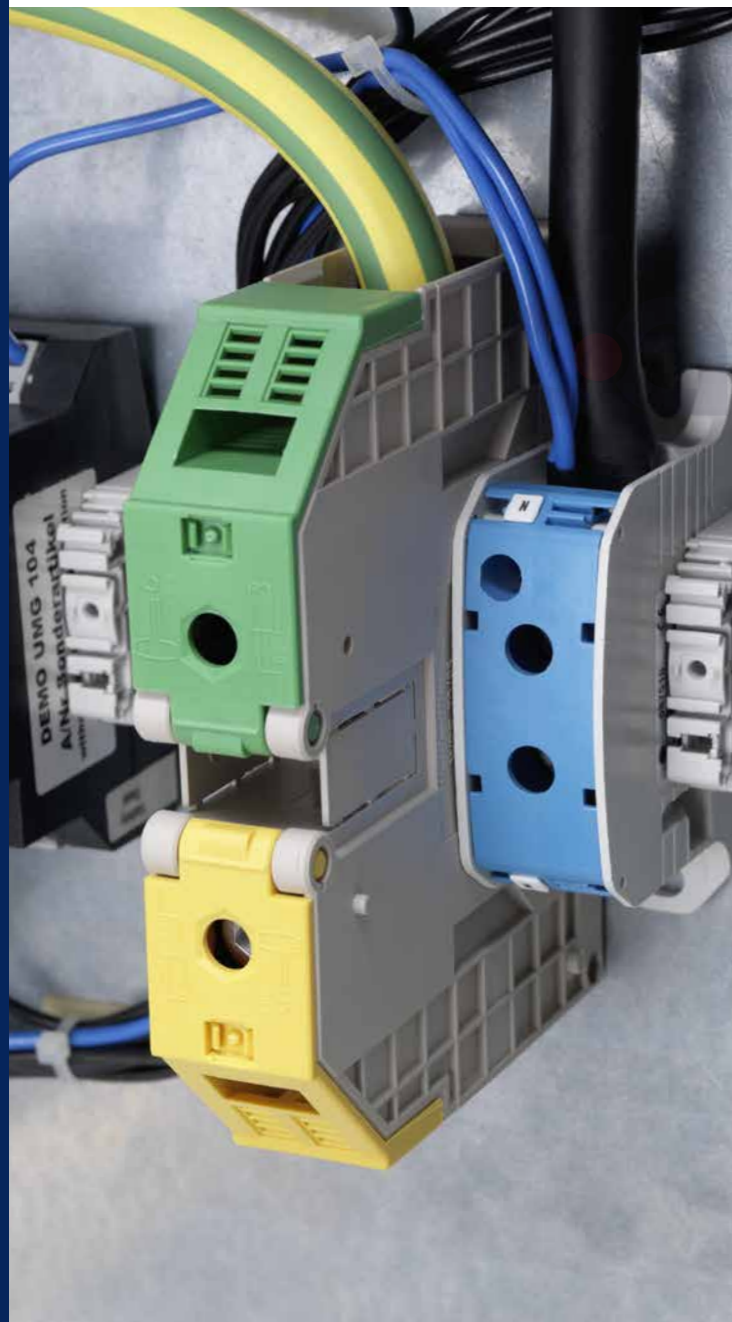

PRODUCT BENEFITS

- > Cost, weight and space savings from optimized aluminium body and compact design
- > Suitable for all round and sector-shaped solid, stranded or flexible conductors in copper or aluminium in a variety of applications ranging from industry to energy
- > User-friendliness with easy installation as well as additional features and extensive accessories
- > Measurement and control line tapping as standard from RKA 95

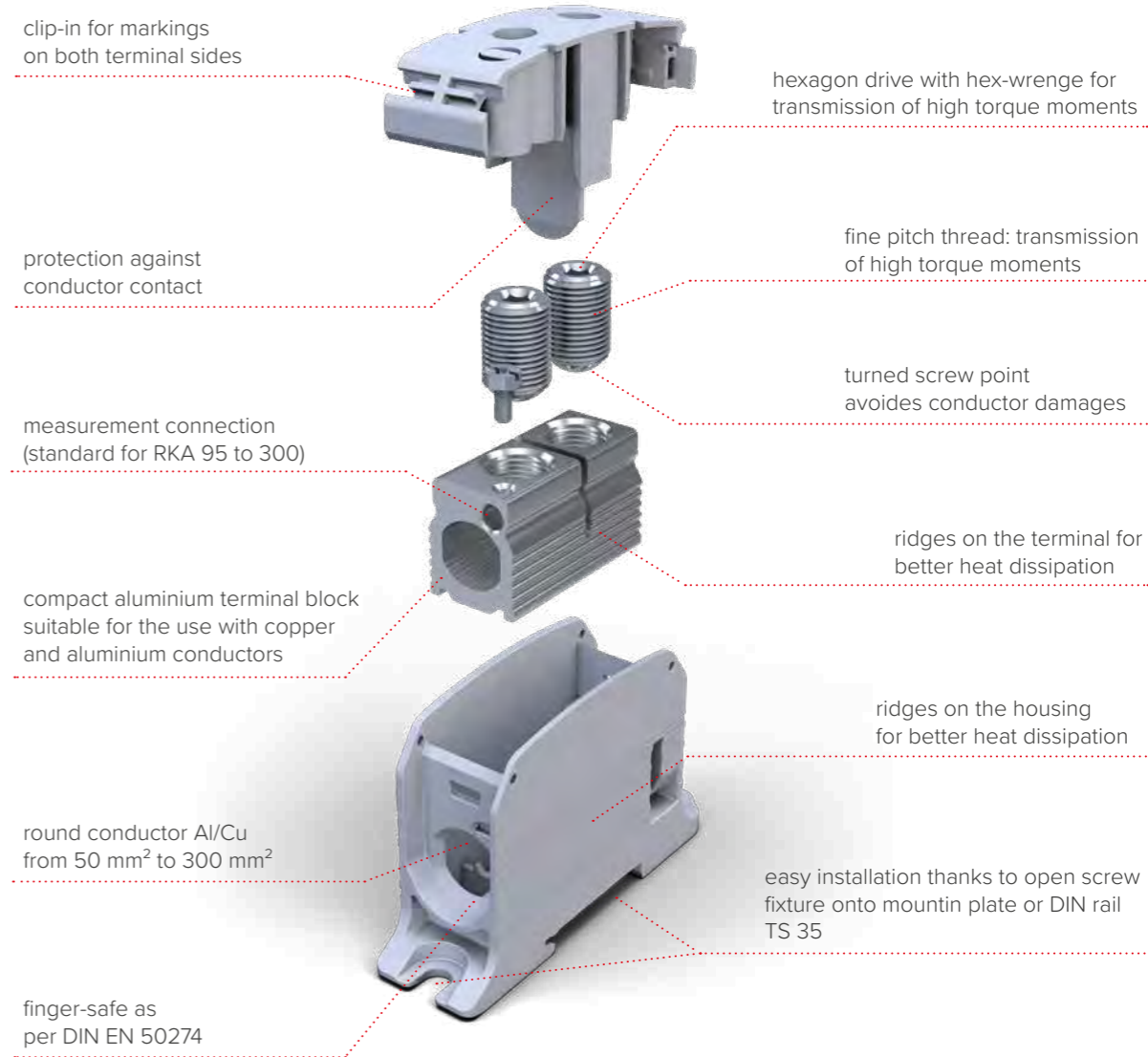

CERTIFICATES

- > IEC 60947-7-1
- > IEC 61238-1 (Class A)
- > UL-1059
- > UL 486E
- > CSA C22.2No.158-10



CONFORMITY



SAFETY



TERMINAL BLOCKS (RKA)

RKA 50 - 1 POLE



087310-0-3

TERMINAL CROSS SECTION

2 x 50 mm² - 6 mm² (1/0 - 10 AWG)
35 mm² - 4 mm²



- > modular system
- > user-defined stackable
- > to fit on DIN rail TS 35 or installation plate



087310-1-3



087310-2-3



087310-3-3



087310-4-3

AL/CU

For aluminium and copper conductors (Al/Cu)

NOMINAL VOLTAGE	NOMINAL CURRENT	STANDARDS
1000 V AC/DC	150 A Cu	IEC 60947-7-1
1000 V AC/DC	150 A Al	EN 61238-1
600 V	150 A Cu / 120 A Al	UL-1059 / CSA C22.2 No.158-10

Model	Part No.	Type	PU	GTIN /EAN
RKA 50 for aluminium/ copper conductors	087310-0-3	RKA 50 L G	9/72	4051589873109
	087310-1-3	RKA 50 N	9/72	4051589873116
	087310-2-3	RKA 50 PE	9/72	4051589873123
	087310-3-3	RKA 50 L B	9/72	4051589873130
	087310-4-3	RKA 50 L S	9/72	4051589873147
Accessories				
	087300-0-0	dust cover for RKA 50 series	54/972	4051589873000



087300-0-0

Dimensions:

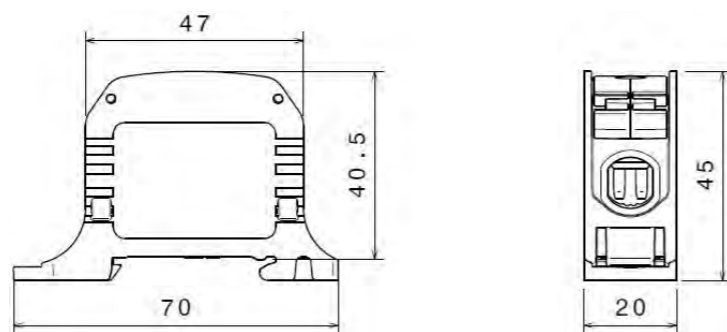

RKA 50 1/4 - 1 POLE



087320-0-3

TERMINAL CROSS SECTION

4 x 50 mm² - 6 mm² (1/0 - 10 AWG)
35 mm² - 4 mm²



- > modular system
- > user-defined stackable
- > to fit on DIN rail TS 35 or installation plate



087320-1-3



087320-2-3



087320-3-3



087320-4-3

AL/CU

For aluminium and copper conductors (Al/Cu)

NOMINAL VOLTAGE	NOMINAL CURRENT	STANDARDS
1000 V AC/DC	150 A Cu	IEC 60947-7-1
1000 V AC/DC	150 A Al	EN 61238-1
600 V	150 A Cu / 120 A Al	UL-1059 / CSA C22.2 No.158-10

Model	Part No.	Type	PU	GTIN /EAN
RKA 50 1/4 for aluminium/ copper conductors	087320-0-3	RKA 50 1/4 L G	5/40	4051589873208
	087320-1-3	RKA 50 1/4 N	5/40	4051589873215
	087320-2-3	RKA 50 1/4 PE	5/40	4051589873222
	087320-3-3	RKA 50 1/4 L B	5/40	4051589873239
	087320-4-3	RKA 50 1/4 L S	5/40	4051589873246
Accessories				
	087300-0-0	dust cover for RKA 50 series	54/972	4051589873000



087300-0-0

Dimensions:

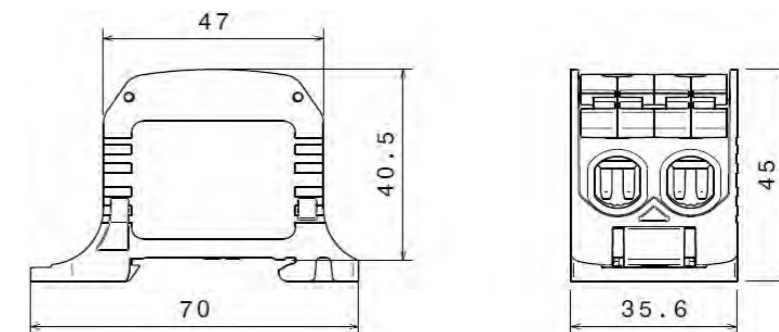

TERMINAL BLOCKS (RKA)

RKA 50 1/6 - 1 POLE



087360-0-3

TERMINAL CROSS SECTION

6 x 50 mm² - 6 mm² (1/0 - 10 AWG)
35 mm² - 4 mm²



- > modular system
- > user-defined stackable
- > to fit on DIN rail TS 35 or installation plate



AL/CU



087360-1-3



087360-2-3



087360-3-3



087360-4-3

For aluminium and copper conductors (Al/Cu)

NOMINAL VOLTAGE	NOMINAL CURRENT	STANDARDS
1000 V AC/DC	150 A Cu	IEC 60947-7-1
1000 V AC/DC	150 A Al	EN 61238-1
600 V	150 A Cu / 120 A Al	UL-1059 / CSA C22.2 No.158-10

Model	Part No.	Type	PU	GTIN /EAN
RKA 50 1/6 for aluminium/ copper conductors	087360-0-3	RKA 50 1/6 L G	3/24	4051589873604
	087360-1-3	RKA 50 1/6 N	3/24	4051589873611
	087360-2-3	RKA 50 1/6 PE	3/24	4051589873628
	087360-3-3	RKA 50 1/6 L B	3/24	4051589873635
	087360-4-3	RKA 50 1/6 L S	3/24	4051589873642
Accessories				
	087300-0-0	dust cover for RKA 50 series	54/972	4051589873000



087300-0-0

Dimensions:

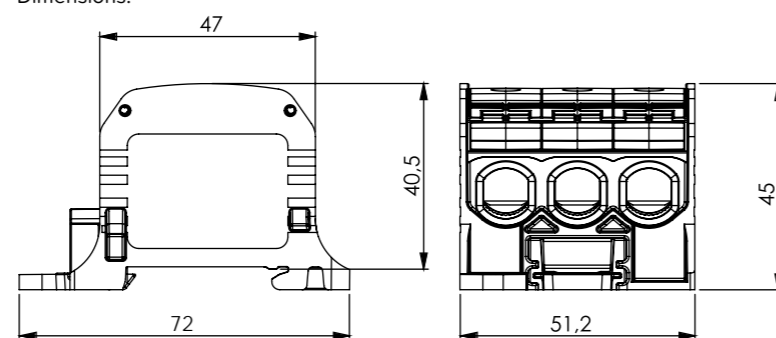

RKA 50 - 3 POLE



087330-0-3

TERMINAL CROSS SECTION (PER POLE)

2 x 50 mm² - 6 mm² (1/0 - 10 AWG)
35 mm² - 4 mm²



- > modular system
- > user-defined stackable
- > to fit on DIN rail TS 35 or installation plate



AL/CU



087330-1-3



087330-5-3

For aluminium and copper conductors (Al/Cu)

NOMINAL VOLTAGE	NOMINAL CURRENT	STANDARDS
1000 V AC/DC	150 A Cu	IEC 60947-7-1
1000 V AC/DC	150 A Al	EN 61238-1
600 V	150 A Cu / 120 A Al	UL-1059 / CSA C22.2 No.158-10

Model	Part No.	Type	PU	GTIN /EAN
RKA 50 3P for aluminium/ copper conductors	087330-0-3	RKA 50 3P 3L G	3/24	4051589873307
	087330-1-3	RKA 50 3P L G/N/PE	3/24	4051589873314
	087330-2-3	RKA 50 3P PE/ L G/N	3/24	4051589873321
	087330-5-3	RKA 50 3P 3L BSG	3/24	4051589873352
	Accessories			
	087300-0-0	dust cover for RKA 50 series	54/972	4051589873000



087300-0-0

Dimensions:

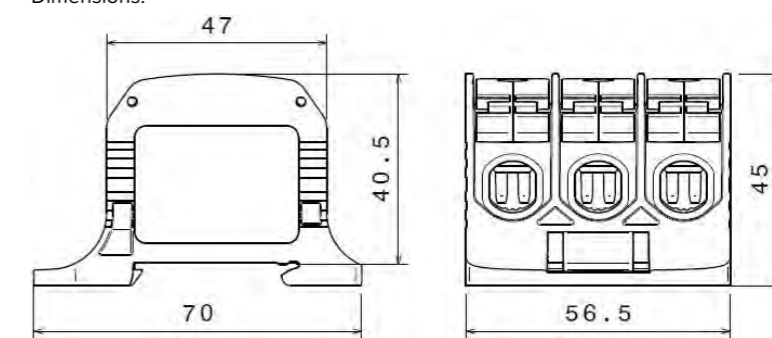

TERMINAL BLOCKS (RKA)

RKA 95 - 1 POLE



087510-0-3

TERMINAL CROSS SECTION

2 x 95 mm² - 16 mm² (3/0 - 6 AWG)
70 mm² - 10 mm²



MEASUREMENT CONNECTION

1 x 10 mm² - 1,5 mm² (8 - 16 AWG)
6 mm² - 1,5 mm² (10 - 16 AWG)



- > modular system
- > user-defined stackable
- > to fit on DIN rail TS 35 or installation plate



AL / CU



087510-1-3



087510-2-3



087510-3-3



087510-4-3

For aluminium and copper conductors (Al/Cu)



NOMINAL VOLTAGE

1000 V AC/DC
1000 V AC/DC
600 V

NOMINAL CURRENT

232 A Cu
200 A Al
200 A Cu / 155 A Al

STANDARDS

IEC 60947-7-1
EN 61238-1
UL-1059 / CSA C22.2 No.158-10



Model	Part No.	Type	PU	GTIN / EAN
RKA 95 for aluminium/ copper conductors	087510-0-3	RKA 95 L G	2/36	4051589875103
	087510-1-3	RKA 95 N	2/36	4051589875110
	087510-2-3	RKA 95 PE	2/36	4051589875127
	087510-3-3	RKA 95 L B	2/36	4051589875134
	087510-4-3	RKA 95 L S	2/36	4051589875141
Accessories				
	087500-0-0	dust cover for RKA 95 series	20/360	4051589875004



087500-0-0

Dimensions:

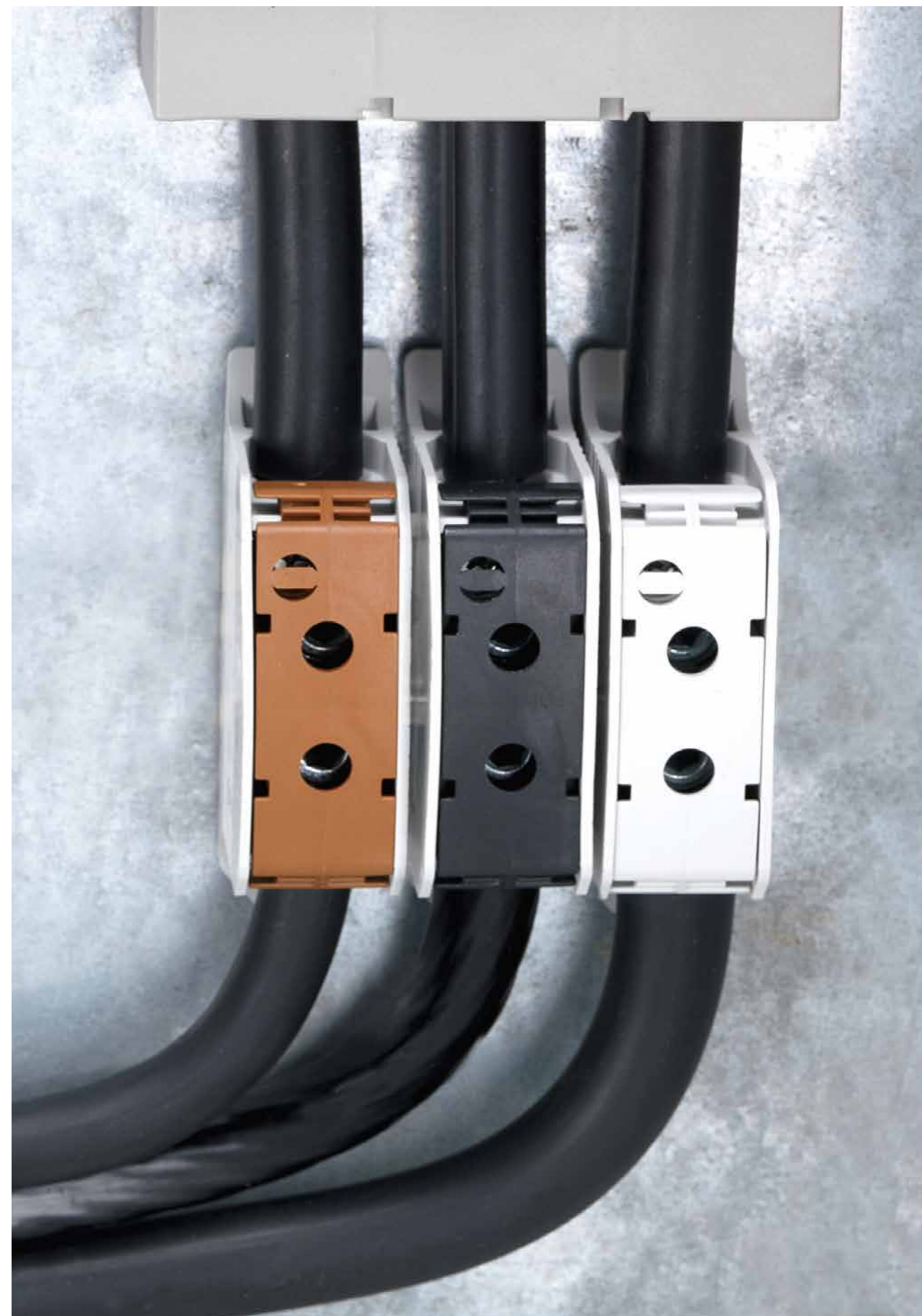
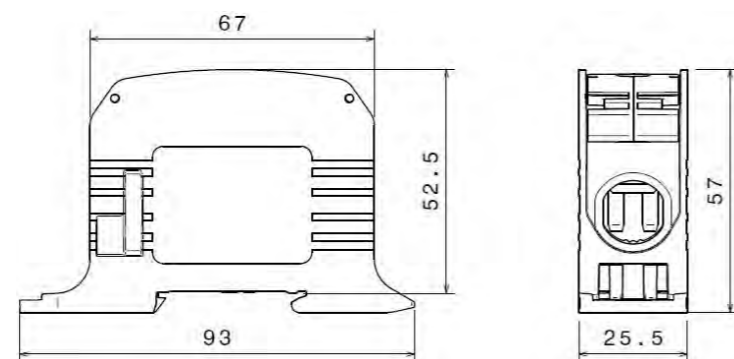

RKA

TERMINAL BLOCKS (RKA)

RKA 95 1/4 - 1 POLE



087520-0-3

TERMINAL CROSS SECTION

4 x 95 mm² - 16 mm² (3/0 - 6 AWG)
70 mm² - 10 mm²



MEASUREMENT CONNECTION

2 x 10 mm² - 1,5 mm² (8 - 16 AWG)
6 mm² - 1,5 mm² (10 - 16 AWG)



- > modular system
- > user-defined stackable
- > to fit on DIN rail TS 35 or installation plate



AL/CU



087520-1-3



087520-2-3



087520-3-3



087520-4-3

RKA 95 1/6 - 1 POLE



087560-0-3

TERMINAL CROSS SECTION

6 x 95 mm² - 16 mm² (3/0 - 6 AWG)
70 mm² - 10 mm²



MEASUREMENT CONNECTION

3 x 10 mm² - 1,5 mm² (8 - 16 AWG)
6 mm² - 1,5 mm² (10 - 16 AWG)



- > modular system
- > user-defined stackable
- > to fit on DIN rail TS 35 or installation plate



AL/CU



087560-1-3



087560-2-3



087560-3-3



087560-4-3

For aluminium and copper conductors (Al/Cu)



NOMINAL VOLTAGE	NOMINAL CURRENT	STANDARDS
1000 V AC/DC	232 A Cu	IEC 60947-7-1
1000 V AC/DC	200 A Al	EN 61238-1
600 V	200 A Cu / 155 A Al	UL-1059 / CSA C22.2 No.158-10

Model	Part No.	Type	PU	GTIN / EAN
RKA 95 1/4 for aluminium/ copper conductors	087520-0-3	RKA 95 1/4 L G	1/18	4051589875202
	087520-1-3	RKA 95 1/4 N	1/18	4051589875219
	087520-2-3	RKA 95 1/4 PE	1/18	4051589875226
	087520-3-3	RKA 95 1/4 L B	1/18	4051589875233
	087520-4-3	RKA 95 1/4 L S	1/18	4051589875240

Accessories

Model	Part No.	Type	PU	GTIN / EAN
087500-0-0	dust cover for RKA 95 series		20/360	4051589875004



087500-0-0

Dimensions:

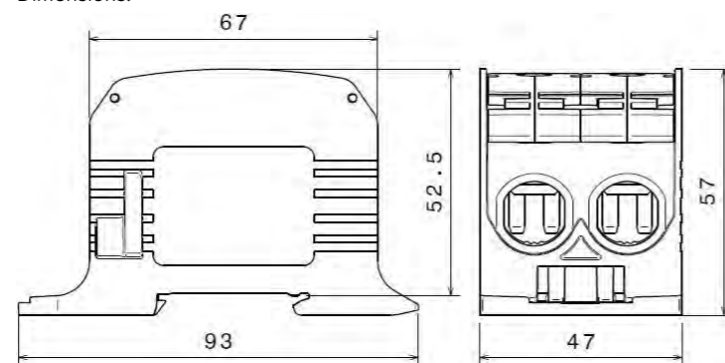

For aluminium and copper conductors (Al/Cu)



NOMINAL VOLTAGE	NOMINAL CURRENT	STANDARDS
1000 V AC/DC	232 A Cu	IEC 60947-7-1
1000 V AC/DC	200 A Al	EN 61238-1
600 V	200 A Cu / 155 A Al	UL-1059 / CSA C22.2 No.158-10

Model	Part No.	Type	PU	GTIN / EAN
RKA 95 1/6 for aluminium/ copper conductors	087560-0-3	RKA 95 1/6 L G	1/12	4051589875608
	087560-1-3	RKA 95 1/6 N	1/12	4051589875615
	087560-2-3	RKA 95 1/6 PE	1/12	4051589875622
	087560-3-3	RKA 95 1/6 L B	1/12	4051589875639
	087560-4-3	RKA 95 1/6 L S	1/12	4051589875646

Accessories

Model	Part No.	Type	PU	GTIN / EAN
087500-0-0	dust cover for RKA 95 series		20/360	4051589875004



087500-0-0

Dimensions:

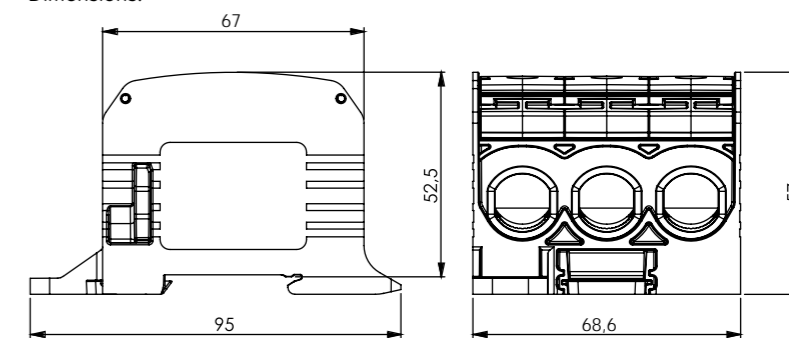

TERMINAL BLOCKS (RKA)

RKA 185 - 1 POLE



087810-0-3

TERMINAL CROSS SECTION

2 x 185 mm² - 95 mm² (350 kcmil - 3/0 AWG)
150 mm² - 70 mm²



MEASUREMENT CONNECTION

1 x 10 mm² - 1,5 mm² (8 - 16 AWG)
6 mm² - 1,5 mm² (10 - 16 AWG)



- > modular system
- > user-defined stackable
- > to fit on DIN rail TS 35 or installation plate



AL / CU



087810-1-3



087810-2-3



087810-3-3



087810-4-3

For aluminium and copper conductors (Al/Cu)



NOMINAL VOLTAGE

1000 V AC/DC
600 V

NOMINAL CURRENT

353 A Cu
310 A Cu / 250 A Al

STANDARDS

IEC 60947-7-1
UL-1059 / CSA C22.2 No.158-10

Model	Part No.	Type	PU	GTIN / EAN
RKA 185	087810-0-3	RKA 185 L G	1/12	4051589878104
	087810-1-3	RKA 185 N	1/12	4051589878111
	087810-2-3	RKA 185 PE	1/12	4051589878128
	087810-3-3	RKA 185 L B	1/12	4051589878135
	087810-4-3	RKA 185 L S	1/12	4051589878142

for aluminium/
copper conductors

Accessories

087800-0-0	dust cover for RKA 185 series	12/216	4051589878005
------------	-------------------------------	--------	---------------



087800-0-0

Dimensions:

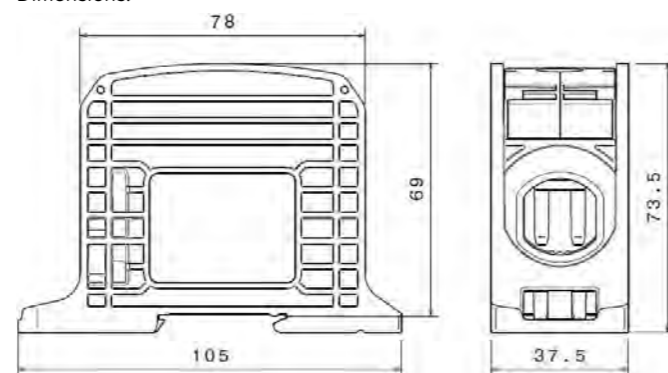

RKA 185 1/4 - 1 POLE



087820-0-3

TERMINAL CROSS SECTION

4 x 185 mm² - 95 mm² (350 kcmil - 3/0 AWG)
150 mm² - 70 mm²



MEASUREMENT CONNECTION

2 x 10 mm² - 1,5 mm² (8 - 16 AWG)
6 mm² - 1,5 mm² (10 - 16 AWG)



- > modular system
- > user-defined stackable
- > to fit on DIN rail TS 35 or installation plate



AL / CU



087820-1-3

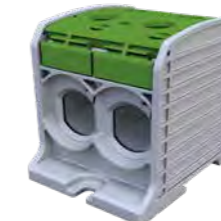

087820-2-3



087820-3-3



087820-4-3

For aluminium and copper conductors (Al/Cu)



NOMINAL VOLTAGE

1000 V AC/DC
600 V

NOMINAL CURRENT

353 A Cu
310 A Cu / 250 A Al

STANDARDS

IEC 60947-7-1
UL-1059 / CSA C22.2 No.158-10

Model	Part No.	Type	PU	GTIN / EAN
RKA 185 1/4	087820-0-3	RKA 185 1/4 L G	1/6	4051589878203
	087820-1-3	RKA 185 1/4 N	1/6	4051589878210
	087820-2-3	RKA 185 1/4 PE	1/6	4051589878227
	087820-3-3	RKA 185 1/4 L B	1/6	4051589878234
	087820-4-3	RKA 185 1/4 L S	1/6	4051589878241

for aluminium/
copper conductors

Accessories

087800-0-0	dust cover for RKA 185 series	12/216	4051589878005
------------	-------------------------------	--------	---------------



087800-0-0

Dimensions:

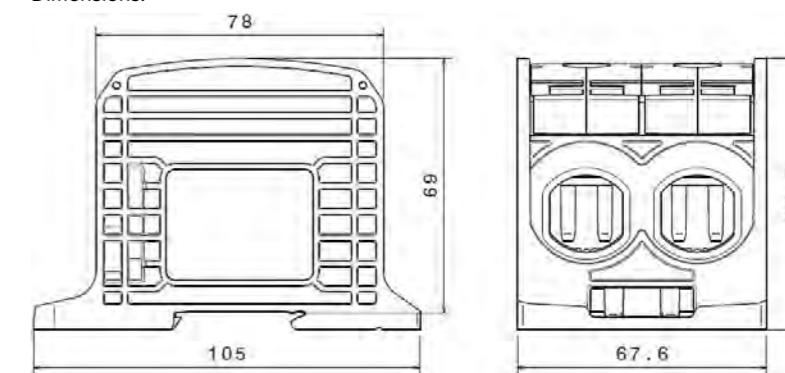

TERMINAL BLOCKS (RKA)

RKA 300 - 1 POLE



087910-0-3

TERMINAL CROSS SECTION

2 x 300 mm² - 150 mm² (600 - 300 kcmil)
240 mm² - 120 mm²



MEASUREMENT CONNECTION

1 x 10 mm² - 1,5 mm² (8 - 16 AWG)
6 mm² - 1,5 mm² (10 - 16 AWG)



- > modular system
- > user-defined stackable
- > to fit on DIN rail TS 35 or installation plate



AL/CU



087910-1-3



087910-2-3



087910-3-3



087910-4-3

RKA 300 1/4 - 1 POLE



087920-0-3

TERMINAL CROSS SECTION

4 x 300 mm² - 150 mm² (600 - 300 kcmil)
240 mm² - 120 mm²



MEASUREMENT CONNECTION

2 x 10 mm² - 1,5 mm² (8 - 16 AWG)
6 mm² - 1,5 mm² (10 - 16 AWG)



- > modular system
- > user-defined stackable
- > to fit on DIN rail TS 35 or installation plate



AL/CU



087920-1-3



087920-2-3



087920-3-3



087920-4-3

For aluminium and copper conductors (Al/Cu)



NOMINAL VOLTAGE
1000 V AC/DC
600 V

NOMINAL CURRENT
520 A Cu
420 A Cu / 340 A Al

STANDARDS
IEC 60947-7-1
UL-1059 / CSA C22.2 No.158-10



Model	Part No.	Type	PU	GTIN /EAN
RKA 300 for aluminium/ copper conductors	087910-0-3	RKA 300 L G	1/12	4051589879101
	087910-1-3	RKA 300 N	1/12	4051589879118
	087910-2-3	RKA 300 PE	1/12	4051589879125
	087910-3-3	RKA 300 L B	1/12	4051589879132
	087910-4-3	RKA 300 L S	1/12	4051589879149
	Accessories			
	087900-0-0	dust cover for RKA 300 series	8/144	4051589879002



087900-0-0

Dimensions:

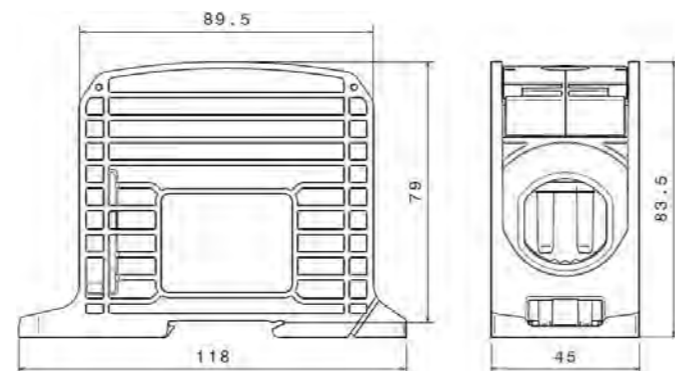

For aluminium and copper conductors (Al/Cu)



NOMINAL VOLTAGE
1000 V AC/DC
600 V

NOMINAL CURRENT
520 A Cu
420 A Cu / 340 A Al

STANDARDS
IEC 60947-7-1
UL-1059 / CSA C22.2 No.158-10



Model	Part No.	Type	PU	GTIN /EAN
RKA 300 1/4 für Aluminium/ Kupferleiter	087920-0-3	RKA 300 1/4 L G	1/6	4051589879200
	087920-1-3	RKA 300 1/4 N	1/6	4051589879217
	087920-2-3	RKA 300 1/4 PE	1/6	4051589879224
	087920-3-3	RKA 300 1/4 L B	1/6	4051589879231
	087920-4-3	RKA 300 1/4 L S	1/6	4051589879248
	Accessories			
	087900-0-0	dust cover for RKA 300 series	8/144	4051589879002



087900-0-0

Dimensions:

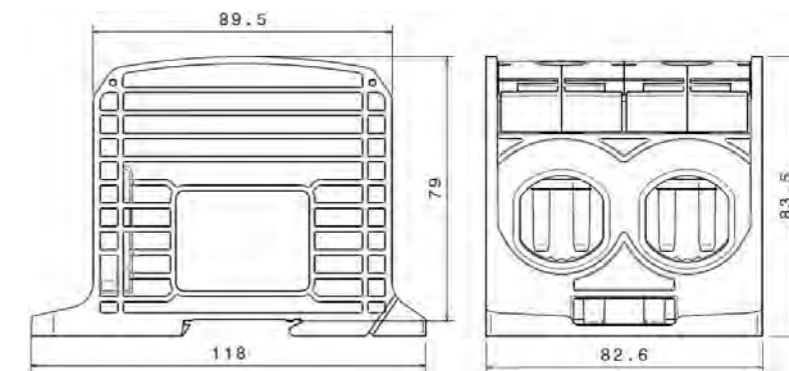

CONDUCTOR CONNECTION TERMINALS (SSAK)



SSAK 16 - fingersafe



086105-0-4

BUSBAR CROSS SECTION / INCOMING

1 x Cu busbar strength (height) 3 - 10 mm
depth (width) minimum 10 mm



OUTGOING

2 x 16 mm² - 1,5 mm²
10 mm² - 1 mm²



086105-1-4



086105-2-4



086105-3-4



086105-4-4

For copper conductors (Cu)

NOMINAL VOLTAGE	NOMINAL CURRENT	STANDARDS
690 V	114 A	IEC 60947-7-1

Model	Part No. *	Type	PU	GTIN /EAN
SSAK 16 for copper conductors	086105-0-4	SSAK 16 L G	12	4051589610506
	086105-1-4	SSAK 16 N	12	4051589610513
	086105-2-4	SSAK 16 PE	12	4051589610520
	086105-3-4	SSAK 16 L B	12	4051589610537
	086105-4-4	SSAK 16 L S	12	4051589610544

* Other colours available on request

Dimensions:

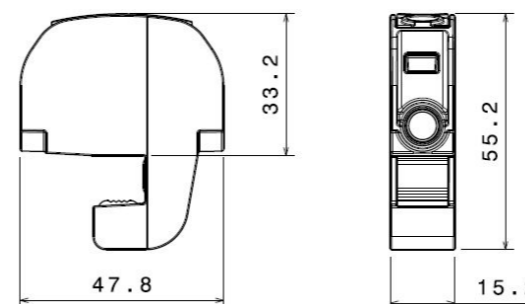

SSAK 10 & 16 - unisolated



NOMINAL VOLTAGE	NOMINAL CURRENT	OUTGOING
690 V	82 A	2 x 10 mm ² SSAK 10
690 V	114 A	2 x 16 mm ² SSAK 16

BUSBAR CROSS SECTION / INCOMING
Cu busbar strength (height) 3 - 10 mm / depth (width) minimum 10 mm

Part no.	Type	PU	GTIN /EAN
086005-9-2	SSAK 10	12	4051589600590
086105-9-2	SSAK 16	12	4051589610599



SSAK

NEUTRAL CONDUCTOR RAIL (NPES)

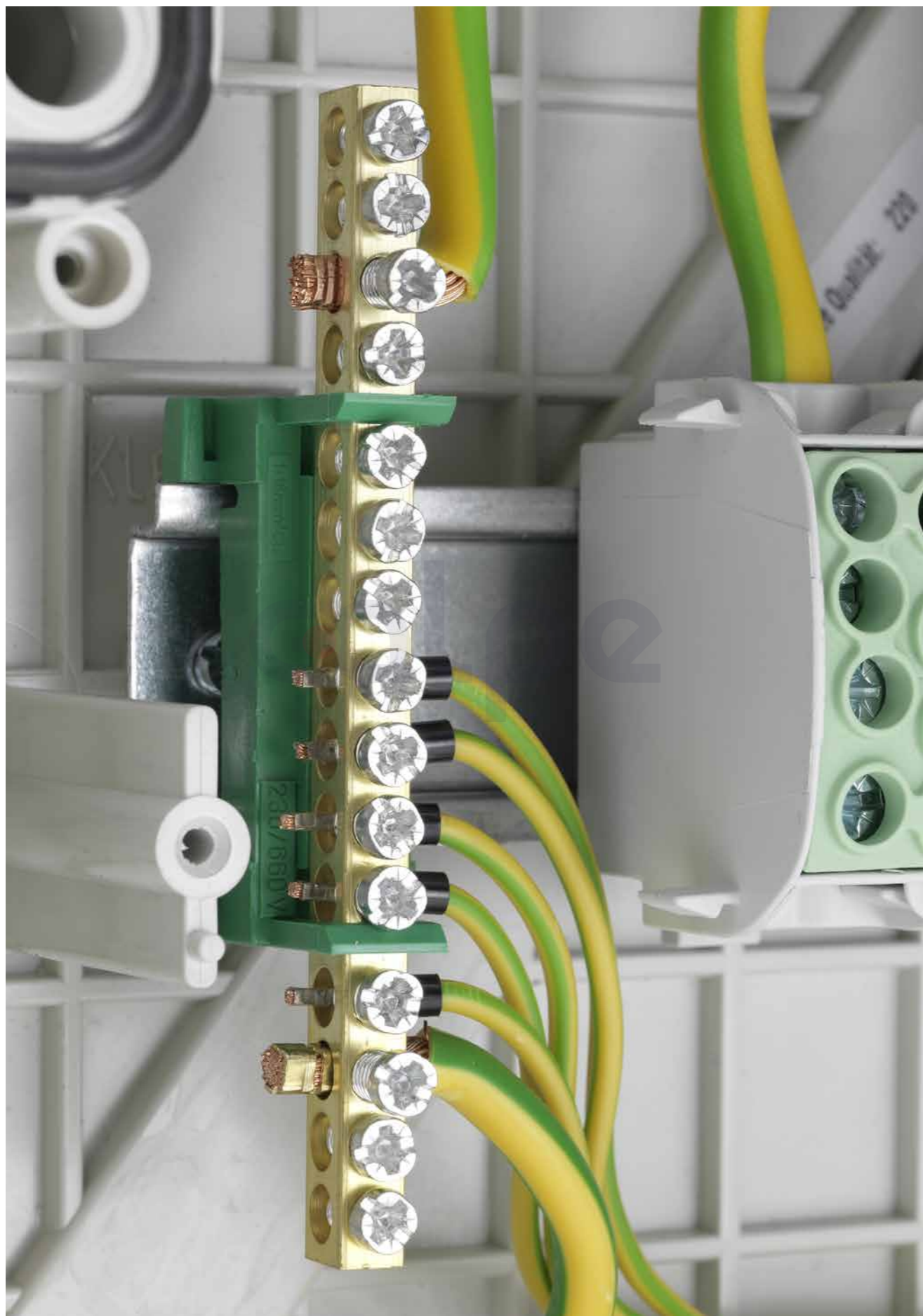

NEUTRAL CONDUCTOR RAIL N 7



NOMINAL VOLTAGE	NOMINAL CURRENT
400 V AC	63 A

TERMINAL CROSS SECTION	DIMENSIONS
7 x 16 mm ²	L x W: 51 x 23 mm

Part no.	PU	GTIN /EAN	Technical Data
083120-0-4	10	4051589312004	-

EARTHING CONDUCTOR RAIL PE 7



NOMINAL VOLTAGE	NOMINAL CURRENT
400 V AC	63 A

TERMINAL CROSS SECTION	DIMENSIONS
7 x 16 mm ²	L x W: 51 x 23 mm

Part no.	PU	GTIN /EAN	Technical Data
083220-0-4	10	4051589322003	-



NPES

UNIVERSAL CONDUCTOR RAIL U 7



NOMINAL VOLTAGE	NOMINAL CURRENT
400 V AC	63 A

TERMINAL CROSS SECTION	DIMENSIONS
7 x 16 mm ²	L x W: 51 x 23 mm

Part no.	PU	GTIN /EAN	Technical Data
083320-0-4	10	4051589332002	-

NEUTRAL CONDUCTOR RAIL (NPES)

NEUTRAL CONDUCTOR RAIL N 12



NOMINAL VOLTAGE	NOMINAL CURRENT
400 V AC	63 A

TERMINAL CROSS SECTION	DIMENSIONS
12 × 16 mm ²	L x W: 85 × 23 mm

Part no.	PU	GTIN /EAN	Technical Data
083120-1-4	10	4051589312011	-

NEUTRAL CONDUCTOR RAIL N 15



NOMINAL VOLTAGE	NOMINAL CURRENT
400 V AC	63 A

TERMINAL CROSS SECTION	DIMENSIONS
15 × 16 mm ²	L x W: 104 × 23 mm

Part no.	PU	GTIN /EAN	Technical Data
083120-2-4	10	4051589312028	-

EARTHING CONDUCTOR RAIL PE 12



NOMINAL VOLTAGE	NOMINAL CURRENT
400 V AC	63 A

TERMINAL CROSS SECTION	DIMENSIONS
12 × 16 mm ²	L x W: 85 × 23 mm

Part no.	PU	GTIN /EAN	Technical Data
083220-1-4	10	4051589322010	-

EARTHING CONDUCTOR RAIL PE 15



NOMINAL VOLTAGE	NOMINAL CURRENT
400 V AC	63 A

TERMINAL CROSS SECTION	DIMENSIONS
15 × 16 mm ²	L x W: 104 × 23 mm

Part no.	PU	GTIN /EAN	Technical Data
083220-2-4	10	4051589322027	-



NPES

UNIVERSAL CONDUCTOR RAIL U 12



NOMINAL VOLTAGE	NOMINAL CURRENT
400 V AC	63 A

TERMINAL CROSS SECTION	DIMENSIONS
12 × 16 mm ²	L x W: 85 × 23 mm

Part no.	PU	GTIN /EAN	Technical Data
083320-1-4	10	4051589332019	-

UNIVERSAL CONDUCTOR RAIL U 15



NOMINAL VOLTAGE	NOMINAL CURRENT
400 V AC	63 A

TERMINAL CROSS SECTION	DIMENSIONS
15 × 16 mm ²	L x W: 104 × 23 mm

Part no.	PU	GTIN /EAN	Technical Data
083320-2-4	10	4051589332026	-

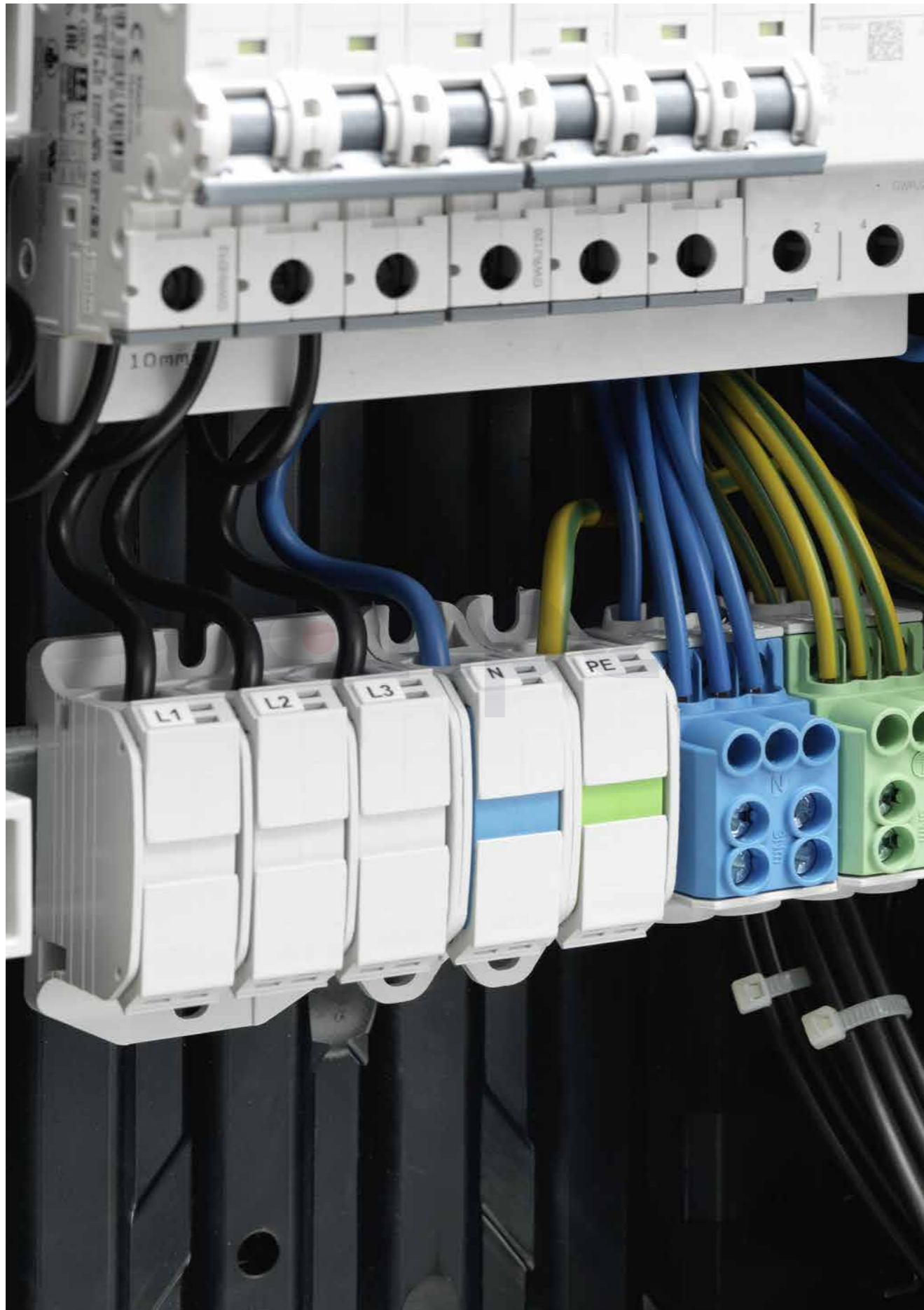

Safe connections for all circuit breakers The HORA eTec busbars

HORA eTec busbars provide a safe and quick connection of circuit breakers, residual current devices and other installation devices. All types are available in two versions: with pin or with fork. The complete HORA eTec busbar portfolio has been tested by VDE. As of today there is no special test standard for busbars.

This is why we configured in accordance with DIN EN 61439-1:2012-06 and DIN EN 61439-6:2013-06 the complete test setup and checked all pin and fork types – the

test report from VDE is available for you on request. The busbars from HORA eTec are allside fingersafe acc. to DIN EN 50274. Accessories such as end caps and feed-in terminals you will find in our portfolio, too. Apart from the standard version we can also offer different pitch lengths, cross sections, special designs and combinations on inquiry.

Tested: VDE Prüf- und Zertifizierungsinstitut GmbH
Technical data: see data sheets

CURRENT RATING

Busbar cross-section in mm ²	1-phase						2,3 and 4-phase			
	10	12	16	20	25	36	10	16	25	36
Feed-in from side maximum busbar current I_s / Phase A	63	65	80	90	100	130	63	80	100	130
Feed-in from middle maximum current per branch I_e / Phase A	100	110	130	150	180	220	100	130	180	220
maximum feed-in current I_e / Phase A	Dependent on the cross section									

Feed-in at start of busbar

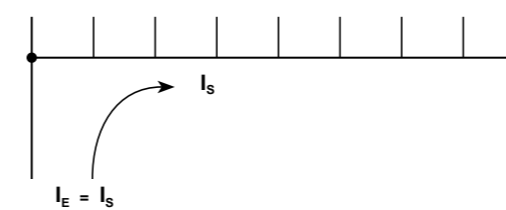

Feeding along the busbar or central feed-in

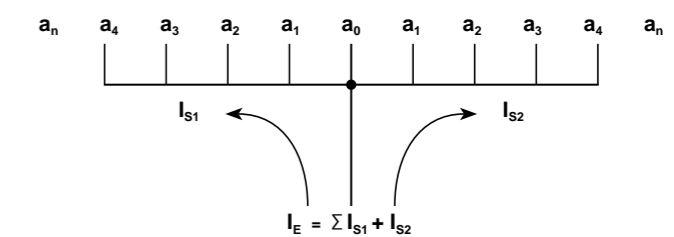

For central supply, it has to be made sure that the sum of the outgoing currents a_0 at each bus branch is not bigger than the above-mentioned max. busbar current I_s / phase

BUSBARS FOR MCBS, MCBS + AUXILIARY CONTACT AND DO

1-pole Fork (M6)



- > cuttable
- > Fingersafe according to DIN EN 50274

SUITABLE END CAP EK 1

EK	mm ²	Part no.	PU	GTIN /EAN
EK 1/10-16	10/16	085931-0-4	10	4051589593106

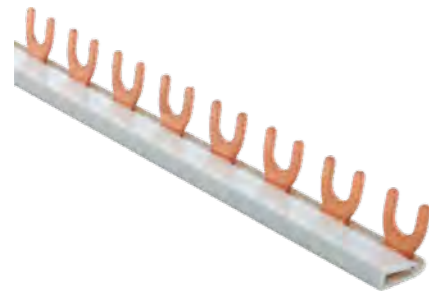

EK 1/10-16

Type	Part no.	Cross section	Nominal Current	Modules	Pitch	PU	GTIN /EAN
G-1L-106/10	085139-9-4	10 mm ²	63 A	6	17,8 + 9 mm	20	4051589513999
G-1L-106/16	085140-9-4	16 mm ²	80 A	6	17,8 mm	20	4051589514095
G-1L-160/10	085141-9-4	10 mm ²	63 A	9	17,8 mm	20	4051589514194
G-1L-160/16	085142-9-4	16 mm ²	80 A	9	17,8 mm	20	4051589514293
G-1L-210/10	085133-9-4	10 mm ²	63 A	12	17,8 mm	20	4051589513395
G-1L-210/16	085134-9-4	16 mm ²	80 A	12	17,8 mm	20	4051589513494
G-1L-268/10	085135-9-4	10 mm ²	63 A	15	17,8 mm	20	4051589513593
G-1L-268/16	085136-9-4	16 mm ²	80 A	15	17,8 mm	20	4051589513692
G-1L-320/10	085137-9-4	10 mm ²	63 A	18	17,8 mm	20	4051589513791
G-1L-320/16	085138-9-4	16 mm ²	80 A	18	17,8 mm	20	4051589513890
G-1L-1000/10	085131-9-4	10 mm ²	63 A	57	17,8 mm	50	4051589513197
G-1L-1000/16	085132-9-4	16 mm ²	80 A	57	17,8 mm	50	4051589513296
G-1L+9-1000/10	085162-9-4	10 mm ²	63 A	37	17,8 + 9 mm	50	4051589516297
G-1L+9-1000/16	085163-9-4	16 mm ²	80 A	37	17,8 + 9 mm	50	4051589516396
G-1L-27-1000/10	085160-9-4	10 mm ²	63 A	37	27 mm	50	4051589516099
G-1L-27-1000/16	085161-9-4	16 mm ²	80 A	37	27 mm	50	4051589516198

BUSBARS FOR MCBS, MCBS + AUXILIARY CONTACT AND DO

1-pole Pin



- > cuttable
- > Fingersafe according to DIN EN 50274

SUITABLE END CAP EK 1

EK	mm ²	Part no.	PU	GTIN /EAN
EK 1/10-16	10/16	085931-0-4	10	4051589593106

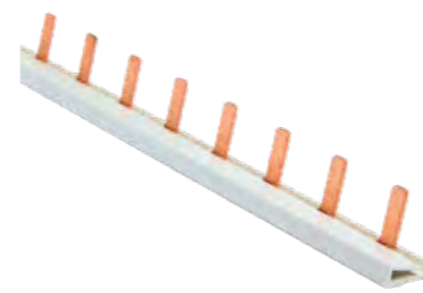

EK 1/10-16

Type	Part no.	Cross section	Nominal Current	Modules	Pitch	PU	GTIN /EAN
S-1L-106/10	085507-9-4	10 mm ²	63 A	6	17,8 mm	20	4051589550796
S-1L-106/16	085508-9-4	16 mm ²	80 A	6	17,8 mm	20	4051589550895
S-1L-160/10	085509-9-4	10 mm ²	63 A	9	17,8 mm	20	4051589550994
S-1L-160/16	085510-9-4	16 mm ²	80 A	9	17,8 mm	20	4051589551090
S-1L-210/10	085501-9-4	10 mm ²	63 A	12	17,8 mm	20	4051589550192
S-1L-210/16	085502-9-4	16 mm ²	80 A	12	17,8 mm	20	4051589550291
S-1L-268/10	085503-9-4	10 mm ²	63 A	15	17,8 mm	20	4051589550390
S-1L-268/16	085504-9-4	16 mm ²	80 A	15	17,8 mm	20	4051589550499
S-1L-320/10	085505-9-4	10 mm ²	63 A	18	17,8 mm	20	4051589550598
S-1L-320/16	085506-9-4	16 mm ²	80 A	18	17,8 mm	20	4051589550697
S-1L-1000/10	085531-9-4	10 mm ²	63 A	57	17,8 mm	50	4051589553193
S-1L-1000/16	085532-9-4	16 mm ²	80 A	57	17,8 mm	50	4051589553292
S-1L+9-1000/10	085562-9-4	10 mm ²	63 A	37	17,8 + 9 mm	50	4051589556293
S-1L+9-1000/16	085563-9-4	16 mm ²	80 A	37	17,8 + 9 mm	50	4051589556392
S-1L-27-1000/10	085560-9-4	10 mm ²	63 A	37	27 mm	50	4051589556095
S-1L-27-1000/16	085561-9-4	16 mm ²	80 A	37	27 mm	50	4051589556194

TOUCH PROTECTION FOR FORK AND PIN BUSBARS

SUITABLE FOR CUTTABLE BUSBARS



BUSBAR TYPE	POLE WIDTH (PITCH)	
1 - 4 phase Fork and Pin	17,6 -18 mm (cuttable)	
Part no.	PU	GTIN /EAN
085990-2-4	10	4051589599023

TOUCH PROTECTION FOR FORK AND PIN BUSBARS

SUITABLE FOR CUTTABLE BUSBARS



BUSBAR TYPE	POLE WIDTH (PITCH)	
1 - 4 phase Fork and Pin	17,6 -18 mm (cuttable)	
Part no.	PU	GTIN /EAN
085990-2-4	10	4051589599023

BUSBARS FOR MCBS, MCBS + AUXILIARY CONTACT AND D0

2-pole Fork (M6)



- > cuttable
- > Fingersafe according to DIN EN 50274

SUITABLE END CAP EK 2 FOR 10MM² AND EK 2/3 FOR 16MM²

EK	mm ²	Part no.	PU	GTIN /EAN
EK 2/10	10	085932-0-4	10	4051589593205
EK 2-3/16	16	085934-0-4	10	4051589593403

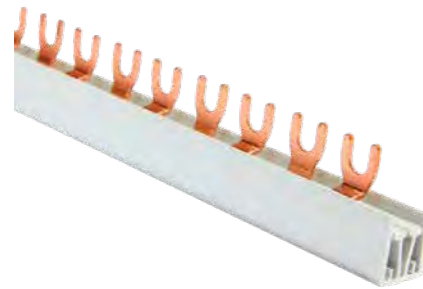

EK 2/10



EK 2-3/16

Type	Part no.	Cross section	Nominal Current	Modules	Pitch	PU	GTIN /EAN
G-2L-106/10	085242-9-4	10 mm ²	63 A	6	17,8 mm	20	4051589524292
G-2L-106/16 C	085243-9-4	16 mm ²	80 A	6	17,8 mm	20	4051589524391
G-2L-210/10	085237-9-4	10 mm ²	63 A	12	17,8 mm	20	4051589523790
G-2L-210/16 C	085238-9-4	16 mm ²	80 A	12	17,8 mm	20	4051589523899
G-2L-320/10	085244-9-4	10 mm ²	63 A	18	17,8 mm	20	4051589524490
G-2L-320/16 C	085245-9-4	16 mm ²	80 A	18	17,8 mm	20	4051589524599
G-2L-1000/10	085230-9-4	10 mm ²	63 A	56	17,8 mm	25	4051589523097
G-2L-1000/16 C	085231-9-4	16 mm ²	80 A	56	17,8 mm	25	4051589523196
G-2L+9-1000/10	085239-9-4	10 mm ²	63 A	46	17,8 + 9 mm	25	4051589523998
G-2L+9-1000/16 C	085233-9-4	16 mm ²	80 A	46	17,8 + 9 mm	25	4051589523394
G-2L-27-1000/10	085240-9-4	10 mm ²	63 A	38	27 mm	25	4051589524094
G-2L-27-1000/16 C	085241-9-4	16 mm ²	80 A	38	27 mm	25	4051589524193

BUSBARS FOR MCBS, MCBS + AUXILIARY CONTACT AND D0

2-pole Pin



- > cuttable
- > Fingersafe according to DIN EN 50274

SUITABLE END CAP EK 2 FOR 10MM² AND EK 2/3 FOR 16MM²

EK	mm ²	Part no.	PU	GTIN /EAN
EK 2/10	10	085932-0-4	10	4051589593205
EK 2-3/16	16	085934-0-4	10	4051589593403

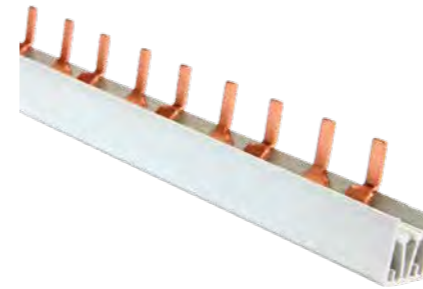

EK 2/10



EK 2-3/16

Type	Part no.	Cross section	Nominal Current	Modules	Pitch	PU	GTIN /EAN
S-2L-106/10	085644-9-4	10 mm ²	63 A	6	17,8 mm	20	4051589564496
S-2L-106/16	085645-9-4	16 mm ²	80 A	6	17,8 mm	20	4051589564595
S-2L-210/10	085638-9-4	10 mm ²	63 A	12	17,8 mm	20	4051589563895
S-2L-210/16	085639-9-4	16 mm ²	80 A	12	17,8 mm	20	4051589563994
S-2L-320/10	085637-9-4	10 mm ²	63 A	18	17,8 mm	20	4051589563796
S-2L-320/16	085646-9-4	16 mm ²	80 A	18	17,8 mm	20	4051589564694
S-2L-1000/10	085630-9-4	10 mm ²	63 A	56	17,8 mm	25	4051589563093
S-2L-1000/16	085631-9-4	16 mm ²	80 A	56	17,8 mm	25	4051589563192
S-2L+9-1000/10	085642-9-4	10 mm ²	63 A	46	17,8 + 9 mm	25	4051589564298
S-2L+9-1000/16	085643-9-4	16 mm ²	80 A	46	17,8 + 9 mm	25	4051589564397
S-2L-27-1000/10	085640-9-4	10 mm ²	63 A	38	27 mm	25	4051589564090
S-2L-27-1000/16	085641-9-4	16 mm ²	80 A	38	27 mm	25	4051589564199

TOUCH PROTECTION FOR FORK AND PIN BUSBARS

SUITABLE FOR CUTTABLE BUSBARS



BUSBAR TYPE	POLE WIDTH (PITCH)	
1 - 4 phase Fork and Pin	17,6 -18 mm (cuttable)	
Part no.	PU	GTIN /EAN
085990-2-4	10	4051589599023

TOUCH PROTECTION FOR FORK AND PIN BUSBARS

SUITABLE FOR CUTTABLE BUSBARS



BUSBAR TYPE	POLE WIDTH (PITCH)	
1 - 4 phase Fork and Pin	17,6 -18 mm (cuttable)	
Part no.	PU	GTIN /EAN
085990-2-4	10	4051589599023

BUSBARS (PS) & ACCESSORIES

BUSBARS FOR MCBS, MCBS + AUXILIARY CONTACT AND DO 3-pole Fork (M6)



- > cuttable
- > Fingersafe according to DIN EN 50274

SUITABLE END CAP EK 3 FOR 10MM² AND EK 2/3 FOR 16MM²

EK	mm ²	Part no.	PU	GTIN /EAN
EK 3/10	10	085933-0-4	10	4051589593304
EK 2-3/16	16	085934-0-4	10	4051589593403

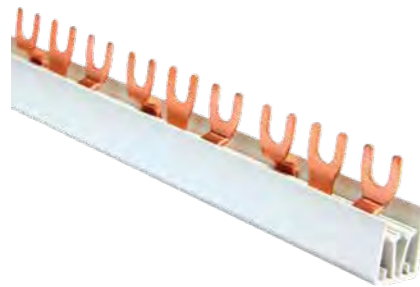

EK 3/10



EK 2-3/16

Type	Part no.	Cross section	Nominal Current	Modules	Pitch	PU	GTIN /EAN
G-3L-106/10 C	085336-9-4	10 mm ²	63 A	6	17,8 mm	20	4051589533690
G-3L-106/16 C	085337-9-4	16 mm ²	80 A	6	17,8 mm	20	4051589533799
G-3L-160/10 C	085338-9-4	10 mm ²	63 A	9	17,8 mm	20	4051589533898
G-3L-160/16 C	085339-9-4	16 mm ²	80 A	9	17,8 mm	20	4051589533997
G-3L-210/10 C	085334-9-4	10 mm ²	63 A	12	17,8 mm	20	4051589533492
G-3L-210/16 C	085335-9-4	16 mm ²	80 A	12	17,8 mm	20	4051589533591
G-3L-268/10 C	085340-9-4	10 mm ²	63 A	15	17,8 mm	20	4051589534093
G-3L-268/16 C	085341-9-4	16 mm ²	80 A	15	17,8 mm	20	4051589534192
G-3L-320/10 C	085342-9-4	10 mm ²	63 A	18	17,8 mm	20	4051589534291
G-3L-320/16 C	085343-9-4	16 mm ²	80 A	18	17,8 mm	20	4051589534390
G-3L-375/10 C	085344-9-4	10 mm ²	63 A	21	17,8 mm	20	4051589534499
G-3L-375/16 C	085345-9-4	16 mm ²	80 A	21	17,8 mm	20	4051589534598
G-3L-1000/10 C	085330-9-4	10 mm ²	63 A	57	17,8 mm	20	4051589533096
G-3L-1000/16 C	085331-9-4	16 mm ²	80 A	57	17,8 mm	20	4051589533195
G-3L+9-1000/10 C	085364-9-4	10 mm ²	63 A	48	17,8 + 9 mm	20	4051589536493
G-3L+9-1000/16 C	085363-9-4	16 mm ²	80 A	48	17,8 + 9 mm	20	4051589536394
G-3L-27-1000/10	085360-9-4	10 mm ²	63 A	36	27 mm	20	4051589536097
G-3L-27-1000/16	085361-9-4	16 mm ²	80 A	36	27 mm	20	4051589536196

BUSBARS FOR MCBS, MCBS + AUXILIARY CONTACT AND DO 3-pole Pin



- > cuttable
- > Fingersafe according to DIN EN 50274

SUITABLE END CAP EK 3 FOR 10MM² AND EK 2/3 FOR 16MM²

EK	mm ²	Part no.	PU	GTIN /EAN
EK 3/10	10	085933-0-4	10	4051589593304
EK 2-3/16	16	085934-0-4	10	4051589593403

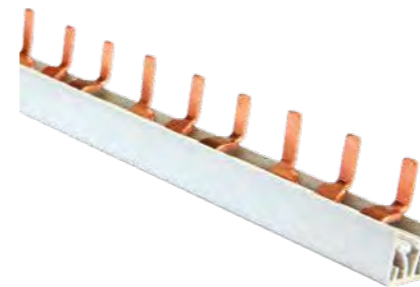

EK 3/10



EK 2-3/16

Type	Part no.	Cross section	Nominal Current	Modules	Pitch	PU	GTIN /EAN
S-3L-106/10	085738-9-4	10 mm ²	63 A	6	17,8 mm	20	4051589573894
S-3L-106/16	085739-9-4	16 mm ²	80 A	6	17,8 mm	20	4051589573993
S-3L-160/10	085740-9-4	10 mm ²	63 A	9	17,8 mm	20	4051589574099
S-3L-160/16	085741-9-4	16 mm ²	80 A	9	17,8 mm	20	4051589574198
S-3L-210/10	085736-9-4	10 mm ²	63 A	12	17,8 mm	20	4051589573696
S-3L-210/16	085737-9-4	16 mm ²	80 A	12	17,8 mm	20	4051589573795
S-3L-268/10	085742-9-4	10 mm ²	63 A	15	17,8 mm	20	4051589574297
S-3L-268/16	085743-9-4	16 mm ²	80 A	15	17,8 mm	20	4051589574396
S-3L-320/10	085744-9-4	10 mm ²	63 A	18	17,8 mm	20	4051589574495
S-3L-320/16	085745-9-4	16 mm ²	80 A	18	17,8 mm	20	4051589574594
S-3L-375/10	085746-9-4	10 mm ²	63 A	21	17,8 mm	20	4051589574693
S-3L-375/16	085747-9-4	16 mm ²	80 A	21	17,8 mm	20	4051589574792
S-3L-1000/10	085730-9-4	10 mm ²	63 A	57	17,8 mm	20	4051589573092
S-3L-1000/16	085731-9-4	16 mm ²	80 A	57	17,8 mm	20	4051589573191
S-3L+9-1000/10	085735-9-4	10 mm ²	63 A	48	17,8 + 9 mm	20	4051589573597
S-3L+9-1000/16	085733-9-4	16 mm ²	80 A	48	17,8 + 9 mm	20	4051589573399
S-3L-27-1000/10	085760-9-4	10 mm ²	63 A	36	27 mm	20	4051589576093
S-3L-27-1000/16	085761-9-4	16 mm ²	80 A	36	27 mm	20	4051589576192

TOUCH PROTECTION FOR FORK AND PIN BUSBARS

SUITABLE FOR CUTTABLE BUSBARS



BUSBAR TYPE	POLE WIDTH (PITCH)	
1 - 4 phase Fork and Pin	17,6 -18 mm (cuttable)	
Part no.	PU	GTIN /EAN
085990-2-4	10	4051589599023

TOUCH PROTECTION FOR FORK AND PIN BUSBARS

SUITABLE FOR CUTTABLE BUSBARS



BUSBAR TYPE	POLE WIDTH (PITCH)	
1 - 4 phase Fork and Pin	17,6 -18 mm (cuttable)	
Part no.	PU	GTIN /EAN
085990-2-4	10	4051589599023

BUSBARS (PS) & ACCESSORIES

BUSBARS FOR MCBS, MCBS + AUXILIARY CONTACT AND DO 4-pole Fork (M6)



- > cuttable
- > Fingersafe according to DIN EN 50274

SUITABLE END CAP EK 4

EK	mm ²	Part no.	PU	GTIN /EAN
EK 4/10-16	10/16	085935-0-4	10	4051589593502

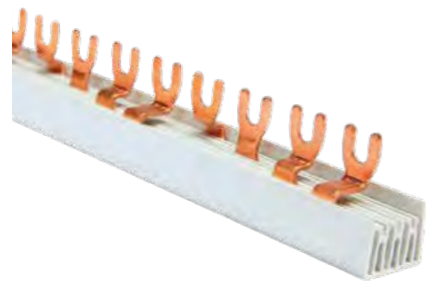

EK 4/10-16

Type	Part no.	Cross section	Nominal Current	Modules	Pitch	PU	GTIN /EAN
G-4L-160/10 C	085445-9-4	10	63 A	8	17,8 mm	20	4051589544597
G-4L-160/16 C	085446-9-4	16	80 A	8	17,8 mm	20	4051589544696
G-4L-210/10 C	085441-9-4	10	63 A	12	17,8 mm	20	4051589544191
G-4L-210/16 C	085442-9-4	16	80 A	12	17,8 mm	20	4051589544290
G-4L-285/10 C	085447-9-4	10	63 A	16	17,8 mm	20	4051589544795
G-4L-285/16 C	085448-9-4	16	80 A	16	17,8 mm	20	4051589544894
G-4L-1000/10 C	085430-9-4	10	63 A	56	17,8 mm	15	4051589543095
G-4L-1000/16 C	085431-9-4	16	80 A	56	17,8 mm	15	4051589543194
G-4L+9-1000/10 C	085449-9-4	10	63 A	36	17,8 + 9 mm	15	4051589544993
G-4L+9-1000/16 C	085432-9-4	16	80 A	48	17,8 + 9 mm	15	4051589543293
G-1L+N-2L+N-3L+N-1000/10 C	085450-9-4	10	63 A	54	17,8 mm	15	4051589545099
G-1L+N-2L+N-3L+N-1000/16 C	085434-9-4	16	80 A	54	17,8 mm	15	4051589543491
G-1L+N+9-2L+N+9-3L+N+9-1000/10 C	085004-0-4	10	63 A	42	17,8 + 9 mm	15	4051589500401
G-1L+N+9-2L+N+9-3L+N+9-1000/16 C	085451-9-4	16	80 A	42	17,8 + 9 mm	15	4051589545198

BUSBARS FOR MCBS, MCBS + AUXILIARY CONTACT AND DO 4-pole Pin



- > cuttable
- > Fingersafe according to DIN EN 50274

SUITABLE END CAP EK 4

EK	mm ²	Part no.	PU	GTIN /EAN
EK 4/10-16	10/16	085935-0-4	10	4051589593502

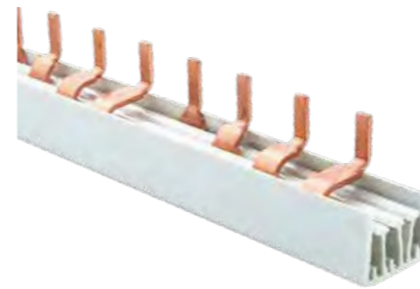

EK 4/10-16

Type	Part no.	Cross section	Nominal Current	Modules	Pitch	PU	GTIN /EAN
S-4L-160/10	085842-9-4	10	63 A	8	17,8 mm	20	4051589584296
S-4L-160/16	085843-9-4	16	80 A	8	17,8 mm	20	4051589584395
S-4L-210/10	085836-9-4	10	63 A	12	17,8 mm	20	4051589583695
S-4L-210/16	085837-9-4	16	80 A	12	17,8 mm	20	4051589583794
S-4L-285/10	085844-9-4	10	63 A	16	17,8 mm	20	4051589584494
S-4L-285/16	085845-9-4	16	80 A	16	17,8 mm	20	4051589584593
S-4L-1000/10	085830-9-4	10	63 A	56	17,8 mm	15	4051589583091
S-4L-1000/16	085831-9-4	16	80 A	56	17,8 mm	15	4051589583190
S-4L+9-1000/10	085839-9-4	10	63 A	36	17,8 + 9 mm	15	4051589583992
S-4L+9-1000/16	085840-9-4	16	80 A	48	17,8 + 9 mm	15	4051589584098
S-1L+N-2L+N-3L+N-1000/10	085010-0-4	10	63 A	54	17,8 mm	15	4051589501002
S-1L+N-2L+N-3L+N-1000/16	085832-9-4	16	80 A	54	17,8 mm	15	4051589583299
S-1L+N+9-2L+N+9-3L+N+9-1000/10	085008-0-4	10	63 A	42	17,8 + 9 mm	15	4051589500807
S-1L+N+9-2L+N+9-3L+N+9-1000/16	085841-9-4	16	80 A	42	17,8 + 9 mm	15	4051589584197

TOUCH PROTECTION FOR FORK AND PIN BUSBARS

SUITABLE FOR CUTTABLE BUSBARS



BUSBAR TYPE	POLE WIDTH (PITCH)	
1 - 4 phase Fork and Pin	17,6 -18 mm (cuttable)	
Part no.	PU	GTIN /EAN
085990-2-4	10	4051589599023

TOUCH PROTECTION FOR FORK AND PIN BUSBARS

SUITABLE FOR CUTTABLE BUSBARS









BUSBAR TYPE	POLE WIDTH (PITCH)	
1 - 4 phase Fork and Pin	17,6 -18 mm (cuttable)	
Part no.	PU	GTIN /EAN
085990-2-4	10	4051589599023

PS

FEED IN TERMINALS FORK AND PIN TYPE CE

Product features

- > Rapid installation
- > Safe bonding by means of screw clamping
- > No special tool needed for crimping cable lugs
- > Fingersafe according to DIN EN 50274
- > General-purpose power directions (front / side)

	mm ²	Type	Part no.	Fork/Pin dimensions (WxHxL) mm	PU	GTIN /EAN
	25 mm ²	fork	084130-2-4	M6 x 1,3 x 16 mm	10	4051589413022
	25 mm ²	pin	084530-2-4	4,2 x 1,3 x 13,5 mm	10	4051589453028
	25 mm ²	pin	084531-2-4	3,8 x 1,3 x 11,4 mm	10	4051589453127
	50 mm ²	fork	084150-1-4	M6 x 2,5 x 15 mm	3	4051589415019
	50 mm ²	pin	084550-1-4	6,6 x 2,5 x 15 mm	3	4051589455015
	50 mm ²	fork	084151-1-4	M6 x 2,5 x 15 mm	3	4051589415118
	50 mm ²	pin	084551-1-4	6,6 x 2,5 x 15 mm	3	4051589455114

	mm ²	Type	Part no.	Fork/Pin dimensions (WxHxL) mm	PU	GTIN /EAN
	50 mm ²	pin	084553-1-4	6 x 2,5 x 12 (29,5) mm	3	4051589455312
	50 mm ²	pin	084552-1-4	6 x 2,5 x 12 (29,5) mm	3	4051589455213
	90 mm ²	pin	084570-1-4	6,5 x 4 x 23 (41) mm	3	4051589457019
	10 mm ²	pin	084510-2-4	3,25 x 2 x 9,7 mm	10	4051589451024
	10 mm ²	pin	084511-2-4	3,25 x 2 x 9,7 mm	10	4051589451123
	16 mm ²	pin	084590-1-4	8 x 6 x 18	3	4051589459013
	16 mm ²	pin	084591-1-4	5 x 6 x 12,5	3	4051589459112



PS

ALUMINIUM CONNECTOR TERMINALS (ALAK)



1 CONNECTION



084750-0-3 084751-0-3 084781-0-3

2 CONNECTIONS

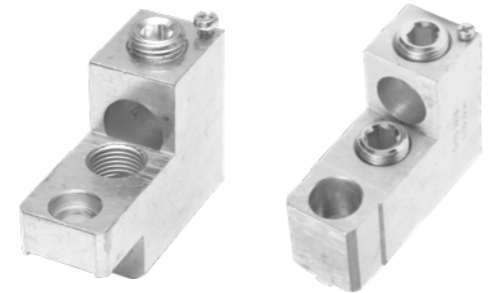

084772-0-3 084782-0-3

4 CONNECTIONS

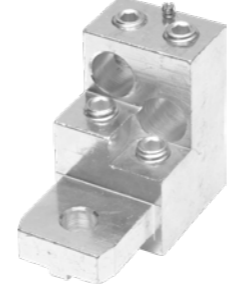

084754-0-3

6 CONNECTIONS



084714-0-3

For aluminium and copper conductors (Al/Cu) CE

Part No.	Stud hole		Connections		Nominal Current	Measurement connection	PU	GTIN /EAN
	Quantity	Ø	Quantity	Cross-sections				
084750-0-3	1	6,2 mm	1	95 mm ² - 16 mm ²	125 A	-	-	4051589475006
084751-0-3	1	8,2 mm	1	95 mm ² - 16 mm ²	250 A	6 mm ² - 1 mm ²	-	4051589475105
084781-0-3	1	10,2 mm	1	240 mm ² - 50 mm ²	630 A	6 mm ² - 1 mm ²	-	4051589478106
084772-0-3	1	8,2 mm	2	150 mm ² - 25 mm ²	250 A	6 mm ² - 1 mm ²	-	4051589477208
084782-0-3	1	10,2 mm	2	240 mm ² - 50 mm ²	630 A	6 mm ² - 1 mm ²	-	4051589478205
084754-0-3	1	10,2 mm	4	95 mm ² - 35 mm ²	630 A	10 mm ² - 1,5 mm ²	-	4051589475402
084714-0-3	1	8,2 mm	6	35 mm ² - 10 mm ²	250 A	-	-	4051589471404



ALAK



HORA eTec GmbH – Werk Lange Straße
Lange Straße 65
32257 Bünde
Germany

Founded: 1919 | Employees: 80 | production area: 5.300 m²



Shiv-Om Brass Industries
Plot No - 3690/3691, Road No - 7
Pramukh Swami Circle, G. I. D. C. Phase - III, Dared
India

Founded: 1992 | Employees: 125 | production area: 13.000 m²



HORA eTec GmbH – Werk Grabenstraße
Grabenstraße 22 - 24
32257 Bünde
Germany



KASEEY ELECTRIC
No 56, Xi An Road
Liushi, Yueqing, Zhejiang
China



INFO



Bettina Hägerbauer
Sales Manager International
+49 (0) 52 23 / 49 80-50
bettina.haegerbaeumer@hora-etec.com



Elisabeth Wollny
Sales Manager International
+49 (0) 52 23 / 49 80-15
elisabeth.wollny@hora-etec.com



Sandy Hua
Sales Manager Asia Region
+49 (0) 52 23 / 49 80-35
sandy.hua@hora-etec.com



Andreas Bartkuhn
Director Finance & Administration
+49 (0) 52 23 / 49 80-32
andreas.bartkuhn@hora-etec.com



Stefanie Janßen
Assistant to the Managing Director
+49 (0) 52 23 / 49 80-17
stefanie.janssen@hora-etec.com



Marcel Weidenhammer
Plant Manager Site Grabenstraße
Technical Support
+49 (0) 52 23 / 49 80-14
marcel.weidenhammer@hora-etec.com



Marion Anger
Sales / Back Office
+49 (0) 52 23 / 49 80-11
marion.anger@hora-etec.com



Simone Dominguez
Sales / Back Office
+49 (0) 52 23 / 49 80-10
simone.dominguez@hora-etec.com



Birte Bollmann
Sales / Back Office
+49 (0) 52 23 / 49 80-52
birte.bollmann@hora-etec.com



Ralf Holtmann
Head of Technical Engineering
+49 (0) 52 23 / 49 80-18
ralf.holtmann@hora-etec.com



Björn Rekersbrink
Technical Engineering
+49 (0) 52 23 / 49 80-38
reckersbrink@hora-etec.com



Jörg Diestelhorst
Head of Production
+49 (0) 52 23 / 49 80-28
joerg.diestelhorst@hora-etec.com



Dirk Heinze
Sales Manager D/A/CH
+49 (0) 52 23 / 49 80-13
dirk.heinze@hora-etec.com



Jessica Gerling
Sales / Back Office
+49 (0) 52 23 / 49 80-12
jessica.gerling@hora-etec.com



Marcel Metauge
Purchasing Manager
+49 (0) 52 23 / 49 80-40
marcel.metauge@hora-etec.com



Björn Ehlert
Technical Support Components
+49 (0) 52 23 / 49 80-22
bjoern.ehlert@hora-etec.com



Christine Schlensker
Purchasing
+49 (0) 52 23 / 49 80-16
christine.schlensker@hora-etec.com



Petra Schlepner
Logistics
+49 (0) 52 23 / 49 80-39
petra.schlepner@hora-etec.com



Dirk Niestrat
Managing Director
+49 (0) 52 23 / 49 80-19
dirk.niestrat@hora-etec.com



Ewald Voß
Product Manager Components
+49 (0) 52 23 / 49 80-34
ewald.voss@hora-etec.com



Rajkumar Thimmarayan
Sales Manager India & Middle East
+91 - 80 41 75 00 55
rajkumar.thimmarayan@hora-etec.com



Nikolas Ortmeyer
Quality Manager
+49 (0) 52 23 / 49 80-24
nikolas.ortmeyer@hora-etec.com



Andreas Weber
Head of IT
+49 (0) 52 23 / 49 80-42
andreas.weber@hora-etec.com

Your experts
at HORA eTec:
You are welcome
to contact us!



INFO

GTCS – GENERAL TERMS OF DELIVERY AND PAYMENT

1. Validity

These terms of business apply to all our bids, contracts, supplies and other services (hereafter referred to as "supplies"), as well as to all future terms of business, even if they have not yet been expressly agreed upon. These terms are said to be effective upon the order being placed or at the very latest upon acceptance of the goods. We hereby expressly reject any other customer terms and conditions; they only apply subject to our express written consent. If a provision is found to be ineffective, the validity of the remaining provisions will be unaffected.

2. Conclusion of contract, documents, protective rights

2.1 Our bids are subject to change. A contract is only concluded once we have confirmed the order in writing. As far as the nature and scope of our supplies are concerned, our written confirmation is exclusively decisive. If we do not confirm the order in writing, the contract is concluded upon completion of the order at the latest. Telephonic or verbal statements made by our representatives require written confirmation prior to becoming legally effective.

2.2 We reserve proprietary rights and copyright for cost estimates, first drafts, drawings and other documents; these may only be provided to third parties subject to our approval. Any drawings and other documents submitted by us within the scope of our bids shall be returned to us at our request if we are not awarded the contract. In instances where we have supplied items based on drawings, models and samples or other documents submitted by the customer, the latter undertakes to ensure that the protection rights of third parties are not violated. In the event of a third party prohibiting us from the manufacture and supply of such items through recourse to their protection rights, we are entitled – without being obliged to verify our legal position – to take on any further activities and demand compensation for damage insofar as the customer has to respond. The customer also undertakes to immediately release us from all third-party claims relating to documents submitted by him, insofar as the supplier has to respond.

2.3 We reserve the right to bill for the cost of samples and tests parts, as well as for tools required for their manufacture. Manufacturing costs of tools required for batch production will be billed by us unless otherwise agreed. In any event, all tools remain our property, even if the customer bears part or all of their manufacturing costs.

2.4 In the event of make-and-hold orders, we are entitled to procure the materials for the entire order and to produce the entire ordered quantity immediately. Any requests for change made by the customer can therefore not be considered after the contract has been awarded, unless expressly agreed otherwise.

3. Description of service

3.1 The nature of the supplies and services delivered is definitively specified by expressly agreed upon performance characteristics (e.g. specifications, markings, clearance, other data). The product's suitability for specific applications or specific purposes shall only be guaranteed subject to express and written agreement; otherwise, the customer is exclusively liable for application and suitability risks. Any supply and service characteristics other than those agreed upon are not covered. We reserve the right to standard or technically unavoidable deviations from physical and chemical magnitudes, processes and the use of raw materials as well as ordered quantities, insofar as these are deemed reasonable by the customer.

3.2 Details regarding supplies or services (e.g. in catalogues, product literature, electronic media or on labels) are based on our general experience and knowledge and therefore only reflect standard values or characteristics. These product details as well as expressly agreed upon performance characteristics/intended applications do not release the customer from the need to test the product's suitability for its intended purpose.

3.3 Details regarding the nature and possible uses of our products do not come with any guarantees, specifically in terms of §§ 444, 639 BGB, unless these are specifically indicated in writing.

4. Delivery and lead times

4.1 Lead times are only approximate insofar as a variation of up to one (1) month is possible, even if a delivery date has been agreed upon with the customer, unless a fixed delivery date has been agreed upon in writing. Confirmed delivery dates are subject to the correct, complete and punctual delivery of goods to our premises. A lead time is considered to be on schedule if the delivered item leaves our factory before expiry of the deadline, or if we have informed the customer of its readiness for dispatch. The lead time does not come into effect for as long as the customer has not accordingly fulfilled his obligations such as the provision of technical details and documents, loan approvals, part payments or guarantees of payment.

4.2 We are entitled to carry out partial deliveries insofar as these are deemed reasonable by the customer and are not subsequently detrimental to usage.

4.3 Force majeure occurrences, industrial action measures including strikes and/or lockouts, and other circumstances for which we are not responsible, which are beyond our control, and which make it impossible to complete an order within the deadline release us from our delivery obligations for the duration of their occurrence.

4.4 The return of sold, defect-free goods is prohibited in principle.

4.5 Applications for insolvency, declarations in lieu of an oath as per § 807 ZPO, emergent payment difficulties or signs of significant deterioration in the customer's financial position entitle us to call off deliveries immediately and to refuse the fulfilment of current contracts for as long as the customer has not provided consideration in return or provided the appropriate security at our request, without the customer being able to withdraw from the contract or demand damage compensation.

5. Dispatch and transfer of liability

5.1 Liability for the delivery is transferred to the customer upon departure from our factory premises.

5.2 Liability is transferred to the customer when the goods are ready for dispatch but dispatch is held up for reasons beyond our control and for which we are not responsible.

6. Packaging

Single-use packaging is not taken back.

7. Securities

7.1 We reserve the right to ownership of all our delivered good up until the time that all receivables, including partial and incidental ones owed to us by the customer within the scope of our business relationship, have been paid; in this respect, all deliveries are considered as being one comprehensive delivery transaction. With regard to current invoices, reserved ownership is held to be a security for receivables due. The above provisions also apply to future receivables.

7.2 The customer is entitled to sell on the purchase item in due course of business. He is also entitled to process or combine it; as such, he thereupon assigns us all receivables resulting from subsequent disposal, processing, combination or other judicial reasons relating to the purchase item (in particular from insurance contracts or unauthorised dealings) to the value of the invoiced total (incl. VAT). Subsequent disposal denotes usage made by the customer for the purpose of contracts of manufacture or supply.

7.3 The ownership claim also extends to those products resulting from the processing, mixing or combination of our goods, at their full value, with the outcome being that we are considered as the manufacturers of these products.

Should the processing, mixing or combination with goods of a third party give rise to the latter's proprietary rights, we shall then acquire co-ownership in proportion to the objective value of these goods. Should our ownership expire due to the combination or mixing of goods, the customer shall thereupon assign us his ownership and/or reversion rights to the new stock or item to the extent of the invoiced amount of the goods supplied by us, and shall safeguard them for us free of charge.

7.4 Notwithstanding the assignment of his rights, the customer is entitled to call in receivables arising from subsequent disposal, as long as we have not withdrawn this entitlement. We will not call in the receivables ourselves, provided that the customer duly fulfils his payment obligations towards us. Upon our first written request, the customer is obliged to provide us with the details of the debtors of the assigned receivables, and to inform the debtors of the assignment.

7.5 In accordance with clause 7.2, we are entitled to withdraw the customer's right to further disposal and to collection of receivables assigned to us with immediate effect if the customer defaults on payments due to us, if he encounters payment difficulties due to a significant deterioration in his financial position, or if he fails to fulfil his commitments towards us accordingly. In the event of the customer's application for insolvency, in the event of any default in payment, in the event of a declaration being made in lieu of an oath as per § 807 ZPO or in the event of changes in ownership of the customer's company due to payment difficulties, the right to further disposal and collection of receivables assigned to us will expire automatically.

7.6 The customer shall safeguard the items forming part of our (joint) property with the care of a respectable trader and free of charge, and will ensure these items against fire, burglary and other risks.

7.7 The customer is prohibited from mortgaging or pawning any supplied goods that are subject to reservation of proprietary rights. In the event of seizure or any other prejudice to our proprietary rights on the part of a third party, the customer shall immediately inform us thereof and also confirm the proprietary rights both toward us and the third party in writing. Any remaining costs incurred upon us in spite of the successful outcome of an ensuing legal dispute shall be borne by the customer.

7.8 Applications for insolvency, declarations in lieu of an oath as per § 807 ZPO, or signs of significant deterioration in the customer's financial position, which pose a serious threat to our payment claim and entitle us to cancel the contract, entitle us to recover the goods; in such an instance, the customer hereby agrees to such recovery. Should this recovery occur, the Parties agree that we will refund or otherwise settle the costs at the usual market value at the time of recovery. Recovery of goods is only tantamount to withdrawal from the contract if this is expressly stated by us. Costs incurred by recovery (such as transportation costs) shall be borne by the customer. In cases where there has been no official notice of withdrawal, the customer may only request the delivery of recovered goods once he has paid the full purchase price and all other costs.

7.9 Securities owed to us will not be collected if the value of our securities exceeds the nominal value of the securable receivables by 20 %. The customer can request the express removal of supplied goods from the reserved property as long as the overcollateralisation does not exceed 20%.

8. Prices and payment

8.1 Our prices are given in EURO ex delivering works and do not include VAT.

8.2 Unforeseen changes in the cost of raw materials, labour, material and energy beyond our control entitle us to adjust our prices accordingly, of up to 5 %, if at least four (4) weeks lie between the conclusion of the contract and the anticipated delivery date. In the event of part deliveries, each delivery may be invoiced separately. If no prices have been set upon

conclusion of the contract, we shall apply the price in effect on the day of delivery.

8.3 If no other payment arrangements have been agreed upon in writing, our invoices fall due for payment immediately with no deductions.

8.4 We are not obliged to accept bills of exchange, cheques and other promissory notes; they are always accepted for the sake of fulfilment.

8.5 The date of receipt of payment is the date on which the amount is made available to us or has been credited to our bank account. If the customer delays payment, we are entitled to charge interest at a rate of 8 % p.a. above the basic interest rate for the duration of the default period. This does not restrict our right to demand further damage compensation.

8.6 If the customer is unable to pay, all receivables owed by the customer from this and other contracts fall due immediately. Furthermore, deliveries forming part of this or of other contracts may be detached from a previous security or a step-by-step payment method.

8.7 We do not allow interest on advance and/or interim payments.

8.8 The customer is not entitled to offset or withhold payments if his counterclaim is undisputed or deemed to be legally valid by us.

9. Claims against defects

9.1 We are liable for defects found on goods supplied by us in accordance with the following provisions only:

9.2 The customer shall duly fulfil his inspection and claim obligations in accordance with § 377 HGB.

9.3 Complaints shall only be accepted by us if they are submitted in writing. Complaints lodged against sales representatives, carriers or other third parties shall not be deemed to be filed in due form and due time.

9.4 In the event of a defective consignment, we reserve the opportunity – prior to the start of production (processing or installation) – to resolve/eliminate the defect or redeliver the goods, unless the customer deems this unreasonable. In the event of our inability to do this or in the event of our failure to fulfil this commitment immediately, the customer may then return the goods at our risk. In urgent cases, he can – subject to our approval – eliminate the defect by his own means or by means of a third party at our cost.

9.5 If the defect is detected only after the start of production – despite compliance with the obligation stipulated in clause 9.2 – the customer may demand rectification (either in the form of rework or replacement, depending on our choice).

9.6 In the event of a replacement, the customer is obliged to return the defective item upon our request.

9.7 Annulment of the contract or a reduction in the purchase price shall only be granted if the defect cannot be rectified within a reasonable period, if rectification of the defect is likely to incur disproportionate costs, if rectification of the defect is deemed to be unreasonable or for other reasons, is deemed to have failed. Only in the event of insignificant defects is the customer not entitled to withdraw from the contract.

9.8 In the event of a complaint, the customer shall immediately grant us the opportunity to inspect the goods in question; in particular, the incriminated goods shall be made available to us at our request and at our cost. In the event of unfounded complaints, we reserve the right to demand that the customer bear any transportation and inspection expenses.

9.9 Defect claims shall not be accepted if the fault is due to non-compliance with operating, maintenance and installation instructions, to inappropriate or improper use or storage, to improper or negligent handling or assembly, to natural wear and tear, or to intervention on the part of the customer or a third party.

9.10 The customer may only demand damage compensation and reimbursement for defects due to costs incurred through dismounting and assembly, as well as associated transportation costs, if this has been agreed upon by contract. This does not apply if the defect was caused deliberately or through gross negligence and/or resulted in injury to life, body or health.

9.11 For products that are not delivered as new in accordance with the agreement, the customer is not entitled to the above-mentioned claims.

10. Liability

10.1 We shall be liable for all types of damage compensation claims, in particular with regard to faults pertaining to conclusion of the contract, breach of obligations and unauthorised actions (§§ 823 ff BGB), if we, our staff or associates are found to be guilty of intentional misdemeanour or gross negligence.

10.2 In the event of damage resulting from death, bodily harm, compromised health, breach of guarantee or breach of basic contractual obligations, we shall also be liable for slight negligence. In the event of a breach of basic contractual obligations, our liability shall be limited – depending on the type of goods – to foreseeable, contractually standard and direct average damages. This provision also applies to contractual breaches committed by our staff and associates.

10.3 In the event of breached protection rights, we are liable in terms of the above-mentioned provisions, inasmuch and insofar as these protection rights are violated during the contractually valid use of our goods, provided that these rights are valid in the Federal Republic of Germany and on condition that they are published at the time of our delivery. This does not apply if we have manufactured the supplied items on the basis of drawings and models or similar descriptions or details provided by the customer and are not aware, or are not expected to be aware that protection rights have been breached as a result of

products developed by us.

10.4 Our liability in terms of the provisions of product liability law remains unaffected by the above provisions.

10.5 The statute of limitations for claims arising from defects in delivered products becomes effective 1 year after acceptance of the products, however not exceeding 14 months after the transfer of risk, unless the acceptance is delayed for reasons for which the customer is not responsible. This does not apply to an item that has been accordingly used for a building and has resulted in the latter's defectiveness; in such instances, the statute of limitations becomes effective after a 5-year period.

10.6 Reduction and withdrawal claims shall not be admitted once the statute of limitations for rectification claims has come into effect.

10.7 Claims associated with the manufacturer's right of recourse remained unaffected by this paragraph.

10.8 Furthermore, we shall not be held liable.

11. Place of performance, place of jurisdiction, other agreements

11.1 The customer is only entitled to bring claims arising from the contract subject to our prior agreement.

11.2 The place of performance for all claims arising from business ties and more specifically from our deliveries is the place from which the delivery was performed.

11.3 The place of jurisdiction for all claims arising from business ties and more specifically from our deliveries is that of the current of our head office. This place of jurisdiction also applies for disputes regarding the conclusion and effectiveness of the contract. However, we are also entitled to bring an action against the customer before the competent courts for his head office.

11.4 The law of the Federal Republic of German applies exclusively, without possibility of recourse to its international private legislation, insofar as it refers to the validity of another legal system. Application of the United Nations Convention on Contracts for the International Sale of Goods is not admissible.



INFO



SMALL OR LARGE CROSS SECTIONS?

HORA eTec electric terminals
deliver reliable connections.

experts in electrical technology since 1919



HORA eTec GmbH

Lange Straße 65

D - 32257 Bünde

+49 (0) 52 23 / 49 80-0

info@hora-etec.com



experts in electrical technology since 1919

hora-etec.com