



# 14 Miniature and residual circuit breakers



- UL 1077 and UL 489 certified versions
- High breaking capacity
- Various trip characteristic curves: Type B, C or D
- Wide 1...125A current range
- Residuals with trip characteristic curves type A, AC and B
- Switch disconnectors
- Accessories available.

|   | <b>SEC. - PAGE</b> |
|---|--------------------|
| <b>Miniature circuit breakers 1...63A, UL 1077</b>                                  |                    |
| 1P - 10kA, 1 module, curve types B, C and D .....                                   | 14 - 2             |
| 1P+N - 6kA, 1 module, curve type C .....  | 14 - 3             |
| 1P+N - 6kA, 2 modules, curve type C .....   | 14 - 3             |
| 2P - 10kA, 2 modules, curve types B, C and D .....                                  | 14 - 4             |
| 3P - 10kA, 3 modules, curve types B, C and D .....                                  | 14 - 5             |
| 4P - 10kA, 4 modules, curve types B, C and D .....                                  | 14 - 6             |
| <b>Miniature circuit breakers 1...63A, UL 489</b>                                   |                    |
| 1P - 10kA, 1 module .....   | 14 - 7             |
| 2P - 10kA, 2 modules .....  | 14 - 8             |
| 3P - 10kA, 3 modules .....  | 14 - 9             |
| <b>Miniature circuit breakers 80...125A, UL 1077</b>                                |                    |
| 1P, 2P, 3P and 4P - 10kA, curve type C .....  | 14 - 10            |
| 3P and 4P - 10kA, curve type D .....  | 14 - 10            |
| <b>Add-on blocks and accessories</b> .....  | 14 - 11            |
| <b>Modular switch disconnectors</b> .....   | 14 - 13            |
| <b>Residual blocks</b> .....  | 14 - 13            |
| <b>Residual current operated circuit breakers</b> .....                             | 14 - 14            |
| <b>Residual current operated circuit breakers with overcurrent protection</b> ..... | 14 - 15            |
| <b>Dimensions</b> .....   | <b>14 - 16</b>     |
| <b>Wiring diagrams</b> .....  | <b>14 - 16</b>     |
| <b>Technical characteristics</b> .....  | <b>14 - 17</b>     |



Page 14-2

**MINIATURE CIRCUIT BREAKERS UP TO 63A**

- 1P, 1P+N, 2P, 3P and 4P versions
- IEC rated current In: 1...63A
- IEC short-circuit breaking capacity Icn: 10kA (6kA for 1P+N)
- Trip characteristic curve: Type B, C, D
- UL 1077 or UL 489 certified versions.



Page 14-10

**MINIATURE CIRCUIT BREAKERS 80...125A**

- 1P, 2P, 3P and 4P versions
- IEC rated current In: 80...125A
- IEC short-circuit breaking capacity Icn: 10kA
- Trip characteristic curve: Type C, D
- UL 1077 certified versions.



Page 14-11

**ADD-ON BLOCKS AND ACCESSORIES**

- Auxiliary and indicator contacts
- Undervoltage trip releases
- Shunt trip releases
- Connection accessories.



Page 14-13

**SWITCH DISCONNECTORS**

- 1P, 2P, 3P and 4P versions
- IEC rated current In: 32...125A
- Clear OFF contact status indication
- Auxiliary contact block available.



Page 14-13

**RESIDUAL BLOCKS FOR CIRCUIT BREAKERS UP TO 63A**

- 2P, 3P and 4P versions
- IEC rated current In: 40 and 63A
- Residual current: 30 and 300mA
- Residual current operating characteristic: Type A.



Page 14-14

**RESIDUAL CURRENT OPERATED CIRCUIT BREAKERS 25...63A**

- 2P and 4P versions
- IEC rated current In: 25, 40 and 63A
- IEC rated residual operating current IΔn: 30mA and 300mA
- Residual current operating characteristic: Type A, B and AC
- Auxiliary contact and signalling contact blocks available.



Page 14-15

**RESIDUAL CURRENT OPERATED CIRCUIT BREAKERS WITH OVERCURRENT PROTECTION UP TO 40A**

- 1P+N versions
- IEC rated current In: 6...40A
- IEC rated short-circuit capacity Icn: 10kA
- Trip characteristic curve: Type C
- Residual current: 30 and 300mA
- Residual current operating characteristic: Type AC and A
- Auxiliary contact and signalling contact blocks available.



# 14 Miniature and residual circuit breakers

Miniature circuit breakers 1...63A, UL 1077



## 1P - 10kA (IEC/EN/BS) 1 module



P1MB1P...



| Order code | Curve | IEC In | IEC Icn | N° of DIN module | Qty per pkg | Wt   |
|------------|-------|--------|---------|------------------|-------------|------|
|            |       | [A]    | [kA]    | n°               | n°          | [kg] |

Single pole, thermal and magnetic trip type, B-curve characteristic.

|           |   |    |    |   |    |       |
|-----------|---|----|----|---|----|-------|
| P1MB1PB01 | B | 1  | 10 | 1 | 12 | 0.115 |
| P1MB1PB02 | B | 2  | 10 | 1 | 12 | 0.115 |
| P1MB1PB03 | B | 3  | 10 | 1 | 12 | 0.115 |
| P1MB1PB04 | B | 4  | 10 | 1 | 12 | 0.115 |
| P1MB1PB06 | B | 6  | 10 | 1 | 12 | 0.115 |
| P1MB1PB08 | B | 8  | 10 | 1 | 12 | 0.115 |
| P1MB1PB10 | B | 10 | 10 | 1 | 12 | 0.115 |
| P1MB1PB13 | B | 13 | 10 | 1 | 12 | 0.115 |
| P1MB1PB16 | B | 16 | 10 | 1 | 12 | 0.115 |
| P1MB1PB20 | B | 20 | 10 | 1 | 12 | 0.115 |
| P1MB1PB25 | B | 25 | 10 | 1 | 12 | 0.115 |
| P1MB1PB32 | B | 32 | 10 | 1 | 12 | 0.115 |
| P1MB1PB40 | B | 40 | 10 | 1 | 12 | 0.115 |
| P1MB1PB50 | B | 50 | 10 | 1 | 12 | 0.115 |
| P1MB1PB63 | B | 63 | 10 | 1 | 12 | 0.115 |

Single pole, thermal and magnetic trip type, C-curve characteristic.

|             |   |     |    |   |    |       |
|-------------|---|-----|----|---|----|-------|
| P1MB1PC01   | C | 1   | 10 | 1 | 12 | 0.115 |
| P1MB1PC01V6 | C | 1.6 | 10 | 1 | 12 | 0.115 |
| P1MB1PC02   | C | 2   | 10 | 1 | 12 | 0.115 |
| P1MB1PC03   | C | 3   | 10 | 1 | 12 | 0.115 |
| P1MB1PC04   | C | 4   | 10 | 1 | 12 | 0.115 |
| P1MB1PC06   | C | 6   | 10 | 1 | 12 | 0.115 |
| P1MB1PC08   | C | 8   | 10 | 1 | 12 | 0.115 |
| P1MB1PC10   | C | 10  | 10 | 1 | 12 | 0.115 |
| P1MB1PC13   | C | 13  | 10 | 1 | 12 | 0.115 |
| P1MB1PC16   | C | 16  | 10 | 1 | 12 | 0.115 |
| P1MB1PC20   | C | 20  | 10 | 1 | 12 | 0.115 |
| P1MB1PC25   | C | 25  | 10 | 1 | 12 | 0.115 |
| P1MB1PC32   | C | 32  | 10 | 1 | 12 | 0.115 |
| P1MB1PC40   | C | 40  | 10 | 1 | 12 | 0.115 |
| P1MB1PC50   | C | 50  | 10 | 1 | 12 | 0.115 |
| P1MB1PC63   | C | 63  | 10 | 1 | 12 | 0.115 |

Single pole, thermal and magnetic trip type, D-curve characteristic.

|             |   |     |    |   |    |       |
|-------------|---|-----|----|---|----|-------|
| P1MB1PD01   | D | 1   | 10 | 1 | 12 | 0.115 |
| P1MB1PD01V6 | D | 1.6 | 10 | 1 | 12 | 0.115 |
| P1MB1PD02   | D | 2   | 10 | 1 | 12 | 0.115 |
| P1MB1PD03   | D | 3   | 10 | 1 | 12 | 0.115 |
| P1MB1PD04   | D | 4   | 10 | 1 | 12 | 0.115 |
| P1MB1PD06   | D | 6   | 10 | 1 | 12 | 0.115 |
| P1MB1PD08   | D | 8   | 10 | 1 | 12 | 0.115 |
| P1MB1PD10   | D | 10  | 10 | 1 | 12 | 0.115 |
| P1MB1PD13   | D | 13  | 10 | 1 | 12 | 0.115 |
| P1MB1PD16   | D | 16  | 10 | 1 | 12 | 0.115 |
| P1MB1PD20   | D | 20  | 10 | 1 | 12 | 0.115 |
| P1MB1PD25   | D | 25  | 10 | 1 | 12 | 0.115 |
| P1MB1PD32   | D | 32  | 10 | 1 | 12 | 0.115 |
| P1MB1PD40   | D | 40  | 10 | 1 | 12 | 0.115 |
| P1MB1PD50   | D | 50  | 10 | 1 | 12 | 0.115 |
| P1MB1PD63   | D | 63  | 10 | 1 | 12 | 0.115 |

### General characteristics

These devices are used to protect against short circuits and overloads of wiring installations and loads in panel boards, office buildings, stores and similar applications. Their purpose is circuit protection, circuit isolation and load operation controls. They have instantaneous trip characteristics defined as follows:

- B-curve: instantaneous trip 3...5 times In for non-inductive or low inductive loads (heating resistors, generators, very long wire lines)
- C-curve: instantaneous trip 5...10 times In for inductive loads (mixed and inductive resistive loads with low inrush current)
- D-curve: instantaneous trip 10...14 times In for highly inductive loads (loads with high inrush and current such as motors).

Main features include:

- IEC rated current In: 1...63A
- Pole width: 17.5mm / 0.69"
- Contact status with flag indicator
- Trip characteristic: curve type B, C and D
- Auxiliary contacts and trip releases mounted on MCB left side
- Fixing on 35mm DIN rail (IEC/EN/BS 60715).

### Operational characteristics

- Dissipation per pole: 3...13W
- IEC rated insulation voltage Ui: 440V
- IEC rated impulse voltage Uimp: 4kV
- IEC rated operational voltage Ue: 230/400VAC
- UL 1077 rated operational voltage: 277VAC
- Short circuit breaking capacity: IEC/EN/BS 10kA - UL 7.5kA 240V - 5kA 277V.

### Certifications and compliance

Certifications obtained: cURus (E369585); EAC; TÜV-Rheinland.  
Compliant with standards: IEC/EN/BS 60898-1, IEC/EN/BS 60947-2, UL 1077, CSA C22.2 n°235.

# 14 Miniature and residual circuit breakers

## Miniature circuit breakers 1...63A

### 1P+N - 6kA 1 module



P1MB1M...

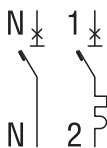

| Order code | Curve | IEC In | IEC Icn | N° of DIN module | Qty per pkg | Wt   |
|------------|-------|--------|---------|------------------|-------------|------|
|            |       | [A]    | [kA]    | n°               | n°          | [kg] |

Single pole + neutral, thermal and magnetic trip type, B-curve characteristic.

|           |   |    |   |   |    |       |
|-----------|---|----|---|---|----|-------|
| P1MB1MB06 | B | 6  | 6 | 1 | 12 | 0.115 |
| P1MB1MB10 | B | 10 | 6 | 1 | 12 | 0.115 |
| P1MB1MB16 | B | 16 | 6 | 1 | 12 | 0.115 |
| P1MB1MB20 | B | 20 | 6 | 1 | 12 | 0.115 |
| P1MB1MB25 | B | 25 | 6 | 1 | 12 | 0.115 |
| P1MB1MB32 | B | 32 | 6 | 1 | 12 | 0.115 |

Single pole + neutral, thermal and magnetic trip type, C-curve characteristic.

|           |   |    |   |   |    |       |
|-----------|---|----|---|---|----|-------|
| P1MB1MC02 | C | 2  | 6 | 1 | 12 | 0.115 |
| P1MB1MC04 | C | 4  | 6 | 1 | 12 | 0.115 |
| P1MB1MC06 | C | 6  | 6 | 1 | 12 | 0.115 |
| P1MB1MC10 | C | 10 | 6 | 1 | 12 | 0.115 |
| P1MB1MC13 | C | 13 | 6 | 1 | 12 | 0.115 |
| P1MB1MC16 | C | 16 | 6 | 1 | 12 | 0.115 |
| P1MB1MC20 | C | 20 | 6 | 1 | 12 | 0.115 |
| P1MB1MC25 | C | 25 | 6 | 1 | 12 | 0.115 |
| P1MB1MC32 | C | 32 | 6 | 1 | 12 | 0.115 |
| P1MB1MC40 | C | 40 | 6 | 1 | 12 | 0.115 |

#### General characteristics

These devices are used to protect against short circuits and overloads of wiring installations and loads in panel boards, office buildings, stores and similar applications. Their purpose is circuit protection, circuit isolation and load operation controls. They have characteristics of instantaneous trip defined as follows:

- B-curve: instantaneous trip 3...5 times In for non-inductive or low inductive loads (heating resistors, generators, very long wire lines)
- C-curve: instantaneous trip 5...10 times In for inductive loads (mixed loads, resistive and inductive with low inrush current)
- D-curve: instantaneous trip 10...14 times In for highly inductive loads (loads with high inrush and current such as motors).

Main features include:

- IEC rated current In: 2...40A
- Pole width: 9mm/0.35" (0.5 module)
- Contact status with flag indicator
- Trip characteristic: curve type B and C
- Auxiliary contacts and trip releases mounted on left side
- Fixing on 35mm DIN rail (IEC/EN/BS 60715).

#### Operational characteristics

- Dissipation per pole: 3...7.5W
- IEC rated insulation voltage Ui: 440V
- IEC rated impulse voltage Uimp: 4kV
- IEC rated operational voltage Ue: 230VAC.

#### Certifications and compliance

Certifications obtained: EAC, TÜV-SUD.  
Compliant with standards: IEC/EN/BS 60898-1, IEC/EN/BS 60947-2.

### 1P+N - 6kA 2 modules



P1MB1N...



| Order code | Curve | IEC In | IEC Icn | N° of DIN module | Qty per pkg | Wt   |
|------------|-------|--------|---------|------------------|-------------|------|
|            |       | [A]    | [kA]    | no.              | n°          | [kg] |

Single pole + neutral, thermal and magnetic trip type, C-curve characteristic.

|           |   |    |   |   |   |       |
|-----------|---|----|---|---|---|-------|
| P1MB1NC01 | C | 1  | 6 | 2 | 6 | 0.190 |
| P1MB1NC02 | C | 2  | 6 | 2 | 6 | 0.190 |
| P1MB1NC04 | C | 4  | 6 | 2 | 6 | 0.190 |
| P1MB1NC06 | C | 6  | 6 | 2 | 6 | 0.190 |
| P1MB1NC10 | C | 10 | 6 | 2 | 6 | 0.190 |
| P1MB1NC16 | C | 16 | 6 | 2 | 6 | 0.190 |
| P1MB1NC20 | C | 20 | 6 | 2 | 6 | 0.190 |
| P1MB1NC25 | C | 25 | 6 | 2 | 6 | 0.190 |
| P1MB1NC32 | C | 32 | 6 | 2 | 6 | 0.190 |
| P1MB1NC40 | C | 40 | 6 | 2 | 6 | 0.190 |
| P1MB1NC50 | C | 50 | 6 | 2 | 6 | 0.190 |
| P1MB1NC63 | C | 63 | 6 | 2 | 6 | 0.190 |

#### General characteristics

- IEC rated current In: 1...63A
- Pole width: 17.5mm / 0.69"
- Contact status with flag indicator
- Trip characteristic: curve type C
- Auxiliary contacts and trip releases mounted on left side
- Fixing on 35mm DIN rail (IEC/EN/BS 60715).

#### Operational characteristics

- Dissipation per pole: 3...13W
- IEC rated insulation voltage Ui: 440V
- IEC rated impulse voltage Uimp: 4kV
- IEC rated operational voltage Ue: 230/400VAC.

#### Certifications and compliance

Certifications obtained: EAC.  
Compliant with standards: IEC/EN/BS 60898-1, IEC/EN/BS 60947-2.



# 14 Miniature and residual circuit breakers

Miniature circuit breakers 1...63A, UL 1077



## 2P - 10kA (IEC/EN/BS) 2 modules



P1MB2P...

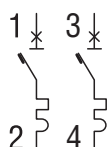

| Order code | Curve | IEC In | IEC Icn | N° of DIN module | Qty per pkg | Wt   |
|------------|-------|--------|---------|------------------|-------------|------|
|            |       | [A]    | [kA]    | n°               | n°          | [kg] |

Two pole, thermal and magnetic trip type, B-curve characteristic.

|           |   |    |    |   |   |       |
|-----------|---|----|----|---|---|-------|
| P1MB2PB01 | B | 1  | 10 | 2 | 6 | 0.230 |
| P1MB2PB02 | B | 2  | 10 | 2 | 6 | 0.230 |
| P1MB2PB04 | B | 4  | 10 | 2 | 6 | 0.230 |
| P1MB2PB06 | B | 6  | 10 | 2 | 6 | 0.230 |
| P1MB2PB10 | B | 10 | 10 | 2 | 6 | 0.230 |
| P1MB2PB13 | B | 13 | 10 | 2 | 6 | 0.230 |
| P1MB2PB16 | B | 16 | 10 | 2 | 6 | 0.230 |
| P1MB2PB20 | B | 20 | 10 | 2 | 6 | 0.230 |
| P1MB2PB25 | B | 25 | 10 | 2 | 6 | 0.230 |
| P1MB2PB32 | B | 32 | 10 | 2 | 6 | 0.230 |
| P1MB2PB40 | B | 40 | 10 | 2 | 6 | 0.230 |
| P1MB2PB50 | B | 50 | 10 | 2 | 6 | 0.230 |
| P1MB2PB63 | B | 63 | 10 | 2 | 6 | 0.230 |

Two pole, thermal and magnetic trip type, C-curve characteristic.

|             |   |     |    |   |   |       |
|-------------|---|-----|----|---|---|-------|
| P1MB2PC01   | C | 1   | 10 | 2 | 6 | 0.230 |
| P1MB2PC01V6 | C | 1.6 | 10 | 2 | 6 | 0.230 |
| P1MB2PC02   | C | 2   | 10 | 2 | 6 | 0.230 |
| P1MB2PC03   | C | 3   | 10 | 2 | 6 | 0.230 |
| P1MB2PC04   | C | 4   | 10 | 2 | 6 | 0.230 |
| P1MB2PC06   | C | 6   | 10 | 2 | 6 | 0.230 |
| P1MB2PC08   | C | 8   | 10 | 2 | 6 | 0.230 |
| P1MB2PC10   | C | 10  | 10 | 2 | 6 | 0.230 |
| P1MB2PC13   | C | 13  | 10 | 2 | 6 | 0.230 |
| P1MB2PC16   | C | 16  | 10 | 2 | 6 | 0.230 |
| P1MB2PC20   | C | 20  | 10 | 2 | 6 | 0.230 |
| P1MB2PC25   | C | 25  | 10 | 2 | 6 | 0.230 |
| P1MB2PC32   | C | 32  | 10 | 2 | 6 | 0.230 |
| P1MB2PC40   | C | 40  | 10 | 2 | 6 | 0.230 |
| P1MB2PC50   | C | 50  | 10 | 2 | 6 | 0.230 |
| P1MB2PC63   | C | 63  | 10 | 2 | 6 | 0.230 |

Two pole, thermal and magnetic trip type, D-curve characteristic.

|             |   |     |    |   |   |       |
|-------------|---|-----|----|---|---|-------|
| P1MB2PD01   | D | 1   | 10 | 2 | 6 | 0.230 |
| P1MB2PD01V6 | D | 1.6 | 10 | 2 | 6 | 0.230 |
| P1MB2PD02   | D | 2   | 10 | 2 | 6 | 0.230 |
| P1MBDPC03   | D | 3   | 10 | 2 | 6 | 0.230 |
| P1MB2PD04   | D | 4   | 10 | 2 | 6 | 0.230 |
| P1MB2PD06   | D | 6   | 10 | 2 | 6 | 0.230 |
| P1MB2PD08   | D | 8   | 10 | 2 | 6 | 0.230 |
| P1MB2PD10   | D | 10  | 10 | 2 | 6 | 0.230 |
| P1MB2PD13   | D | 13  | 10 | 2 | 6 | 0.230 |
| P1MB2PD16   | D | 16  | 10 | 2 | 6 | 0.230 |
| P1MB2PD20   | D | 20  | 10 | 2 | 6 | 0.230 |
| P1MB2PD25   | D | 25  | 10 | 2 | 6 | 0.230 |
| P1MB2PD32   | D | 32  | 10 | 2 | 6 | 0.230 |
| P1MB2PD40   | D | 40  | 10 | 2 | 6 | 0.230 |
| P1MB2PD50   | D | 50  | 10 | 2 | 6 | 0.230 |
| P1MB2PD63   | D | 63  | 10 | 2 | 6 | 0.230 |

### General characteristics

These devices are used to protect against short circuits and overloads of wiring installations and loads in panel boards, office buildings, stores and similar applications.

Their purpose is circuit protection, circuit isolation and load operation controls. They have characteristics of instantaneous trip defined as follows:

- B-curve: instantaneous trip 3...5 times In for non-inductive or low inductive loads (heating resistors, generators, very long wire lines)
- C-curve: instantaneous trip 5...10 times In for inductive loads (mixed loads, resistive and inductive with low inrush current)
- D-curve: instantaneous trip 10...14 times In for highly inductive loads (loads with high inrush and current such as motors).

Main features include:

- IEC rated current In: 1...63A
- Pole width: 17.5mm / 0.69"
- Contact status with flag indicator
- Trip characteristic: curve type B, C and D
- Auxiliary contacts and trip releases mounted on left side
- Fixing on 35mm DIN rail (IEC/EN/BS 60715).

### Operational characteristics

- Dissipation per pole: 3...13W
- IEC rated insulation voltage Ui: 440V
- IEC rated impulse voltage Uimp: 4kV
- IEC rated operational voltage Ue: 230/400VAC
- UL 1077 rated operational voltage: 480VAC
- Short circuit breaking capacity: IEC/EN/BS 10kA - UL 7.5kA 480V.

### Certifications and compliance

Certifications obtained: cURus (E369585); EAC; TÜV-Rheinland.

Compliant with standards: IEC/EN/BS 60898-1, IEC/EN/BS 60947-2, UL 1077, CSA C22.2 n°235.

# 14 Miniature and residual circuit breakers

Miniature circuit breakers 1...63A, UL 1077

## 3P - 10kA (IEC/EN/BS) 3 modules



P1MB3P...

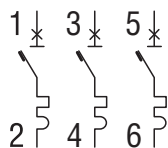

| Order code | Curve | IEC In | IEC Icn | N° of DIN module | Qty per pkg | Wt   |
|------------|-------|--------|---------|------------------|-------------|------|
|            |       | [A]    | [kA]    | n°               | n°          | [kg] |

Three pole, thermal and magnetic trip type, B-curve characteristic.

|           |   |    |    |   |   |       |
|-----------|---|----|----|---|---|-------|
| P1MB3PB01 | B | 1  | 10 | 3 | 4 | 0.345 |
| P1MB3PB02 | B | 2  | 10 | 3 | 4 | 0.345 |
| P1MB3PB04 | B | 4  | 10 | 3 | 4 | 0.345 |
| P1MB3PB06 | B | 6  | 10 | 3 | 4 | 0.345 |
| P1MB3PB10 | B | 10 | 10 | 3 | 4 | 0.345 |
| P1MB3PB13 | B | 13 | 10 | 3 | 4 | 0.345 |
| P1MB3PB16 | B | 16 | 10 | 3 | 4 | 0.345 |
| P1MB3PB20 | B | 20 | 10 | 3 | 4 | 0.345 |
| P1MB3PB25 | B | 25 | 10 | 3 | 4 | 0.345 |
| P1MB3PB32 | B | 32 | 10 | 3 | 4 | 0.345 |
| P1MB3PB40 | B | 40 | 10 | 3 | 4 | 0.345 |
| P1MB3PB50 | B | 50 | 10 | 3 | 4 | 0.345 |
| P1MB3PB63 | B | 63 | 10 | 3 | 4 | 0.345 |

Three pole, thermal and magnetic trip type, C-curve characteristic.

|             |   |     |    |   |   |       |
|-------------|---|-----|----|---|---|-------|
| P1MB3PC01   | C | 1   | 10 | 3 | 4 | 0.345 |
| P1MB3PC01V6 | C | 1.6 | 10 | 3 | 4 | 0.345 |
| P1MB3PC02   | C | 2   | 10 | 3 | 4 | 0.345 |
| P1MB3PC03   | C | 3   | 10 | 4 | 4 | 0.345 |
| P1MB3PC04   | C | 4   | 10 | 3 | 4 | 0.345 |
| P1MB3PC06   | C | 6   | 10 | 3 | 4 | 0.345 |
| P1MB3PC08   | C | 8   | 10 | 3 | 4 | 0.345 |
| P1MB3PC10   | C | 10  | 10 | 3 | 4 | 0.345 |
| P1MB3PC13   | C | 13  | 10 | 3 | 4 | 0.345 |
| P1MB3PC16   | C | 16  | 10 | 3 | 4 | 0.345 |
| P1MB3PC20   | C | 20  | 10 | 3 | 4 | 0.345 |
| P1MB3PC25   | C | 25  | 10 | 3 | 4 | 0.345 |
| P1MB3PC32   | C | 32  | 10 | 3 | 4 | 0.345 |
| P1MB3PC40   | C | 40  | 10 | 3 | 4 | 0.345 |
| P1MB3PC50   | C | 50  | 10 | 3 | 4 | 0.345 |
| P1MB3PC63   | C | 63  | 10 | 3 | 4 | 0.345 |

Three pole, thermal and magnetic trip type, D-curve characteristic.

|             |   |     |    |   |   |       |
|-------------|---|-----|----|---|---|-------|
| P1MB3PD01   | D | 1   | 10 | 3 | 4 | 0.345 |
| P1MB3PD01V6 | D | 1.6 | 10 | 3 | 4 | 0.345 |
| P1MB3PD02   | D | 2   | 10 | 3 | 4 | 0.345 |
| P1MB3PD03   | D | 3   | 10 | 4 | 4 | 0.345 |
| P1MB3PD04   | D | 4   | 10 | 3 | 4 | 0.345 |
| P1MB3PD06   | D | 6   | 10 | 3 | 4 | 0.345 |
| P1MB3PD08   | D | 8   | 10 | 3 | 4 | 0.345 |
| P1MB3PD10   | D | 10  | 10 | 3 | 4 | 0.345 |
| P1MB3PD13   | D | 13  | 10 | 3 | 4 | 0.345 |
| P1MB3PD16   | D | 16  | 10 | 3 | 4 | 0.345 |
| P1MB3PD20   | D | 20  | 10 | 3 | 4 | 0.345 |
| P1MB3PD25   | D | 25  | 10 | 3 | 4 | 0.345 |
| P1MB3PD32   | D | 32  | 10 | 3 | 4 | 0.345 |
| P1MB3PD40   | D | 40  | 10 | 3 | 4 | 0.345 |
| P1MB3PD50   | D | 50  | 10 | 3 | 4 | 0.345 |
| P1MB3PD63   | D | 63  | 10 | 3 | 4 | 0.345 |

### General characteristics

These devices are used to protect against short circuits and overloads of wiring installations and loads in panel boards, office buildings, stores and similar applications. Their purpose is circuit protection, circuit isolation and load operation controls. They have characteristics of instantaneous trip defined as follows:

- B-curve: instantaneous trip 3...5 times I<sub>n</sub> for non-inductive or low inductive loads (heating resistors, generators, very long wire lines)
- C-curve: instantaneous trip 5...10 times I<sub>n</sub> for inductive loads (mixed loads, resistive and inductive with low inrush current)
- D-curve: instantaneous trip 10...14 times I<sub>n</sub> for highly inductive loads (loads with high inrush and current such as motors).

Main features include:

- IEC rated current I<sub>n</sub>: 1...63A
- Pole width: 17.5mm / 0.69"
- Contact status with flag indicator
- Trip characteristic: curve type B, C and D
- Auxiliary contacts and trip releases mounted on left side
- Fixing on 35mm DIN rail (IEC/EN/BS 60715).

### Operational characteristics

- Dissipation per pole: 3...13W
- IEC rated insulation voltage U<sub>i</sub>: 440V
- IEC rated impulse voltage U<sub>imp</sub>: 4kV
- IEC rated operational voltage U<sub>e</sub>: 230/400VAC
- UL 1077 rated operational voltage: 480VAC
- Short circuit breaking capacity: IEC/EN/BS 10kA - UL 7.5kA 480V.

### Certifications and compliance

Certifications obtained: cURus (E369585); EAC; TÜV-Rheinland.  
Compliant with standards: IEC/EN/BS 60898-1, IEC/EN/BS 60947-2, UL 1077, CSA C22.2 n°235.



# 14 Miniature and residual circuit breakers

Miniature circuit breakers 1...63A, UL 1077



## 4P - 10kA (IEC/EN/BS) 4 modules



P1MB4P...

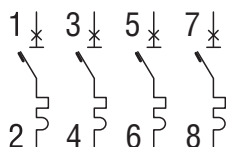

| Order code | Curve | IEC In | IEC Icn | N° of DIN module | Qty per pkg | Wt   |
|------------|-------|--------|---------|------------------|-------------|------|
|            |       | [A]    | [kA]    | n°               | n°          | [kg] |

Four pole, thermal and magnetic trip type, B-curve characteristic.

|           |   |    |    |   |   |       |
|-----------|---|----|----|---|---|-------|
| P1MB4PB01 | B | 1  | 10 | 4 | 3 | 0.460 |
| P1MB4PB02 | B | 2  | 10 | 4 | 3 | 0.460 |
| P1MB4PB04 | B | 4  | 10 | 4 | 3 | 0.460 |
| P1MB4PB06 | B | 6  | 10 | 4 | 3 | 0.460 |
| P1MB4PB10 | B | 10 | 10 | 4 | 3 | 0.460 |
| P1MB4PB13 | B | 13 | 10 | 4 | 3 | 0.460 |
| P1MB4PB16 | B | 16 | 10 | 4 | 3 | 0.460 |
| P1MB4PB20 | B | 20 | 10 | 4 | 3 | 0.460 |
| P1MB4PB25 | B | 25 | 10 | 4 | 3 | 0.460 |
| P1MB4PB32 | B | 32 | 10 | 4 | 3 | 0.460 |
| P1MB4PB40 | B | 40 | 10 | 4 | 3 | 0.460 |
| P1MB4PB50 | B | 50 | 10 | 4 | 3 | 0.460 |
| P1MB4PB63 | B | 63 | 10 | 4 | 3 | 0.460 |

Four pole, thermal and magnetic trip type, C-curve characteristic.

|           |   |    |    |   |   |       |
|-----------|---|----|----|---|---|-------|
| P1MB4PC01 | C | 1  | 10 | 4 | 3 | 0.460 |
| P1MB4PC02 | C | 2  | 10 | 4 | 3 | 0.460 |
| P1MB4PC04 | C | 4  | 10 | 4 | 3 | 0.460 |
| P1MB4PC06 | C | 6  | 10 | 4 | 3 | 0.460 |
| P1MB4PC10 | C | 10 | 10 | 4 | 3 | 0.460 |
| P1MB4PC13 | C | 13 | 10 | 4 | 3 | 0.460 |
| P1MB4PC16 | C | 16 | 10 | 4 | 3 | 0.460 |
| P1MB4PC20 | C | 20 | 10 | 4 | 3 | 0.460 |
| P1MB4PC25 | C | 25 | 10 | 4 | 3 | 0.460 |
| P1MB4PC32 | C | 32 | 10 | 4 | 3 | 0.460 |
| P1MB4PC40 | C | 40 | 10 | 4 | 3 | 0.460 |
| P1MB4PC50 | C | 50 | 10 | 4 | 3 | 0.460 |
| P1MB4PC63 | C | 63 | 10 | 4 | 3 | 0.460 |

Four pole, thermal and magnetic trip type, D-curve characteristic.

|           |   |    |    |   |   |       |
|-----------|---|----|----|---|---|-------|
| P1MB4PD01 | D | 1  | 10 | 4 | 3 | 0.460 |
| P1MB4PD02 | D | 2  | 10 | 4 | 3 | 0.460 |
| P1MB4PD04 | D | 4  | 10 | 4 | 3 | 0.460 |
| P1MB4PD06 | D | 6  | 10 | 4 | 3 | 0.460 |
| P1MB4PD10 | D | 10 | 10 | 4 | 3 | 0.460 |
| P1MB4PD13 | D | 13 | 10 | 4 | 3 | 0.460 |
| P1MB4PD16 | D | 16 | 10 | 4 | 3 | 0.460 |
| P1MB4PD20 | D | 20 | 10 | 4 | 3 | 0.460 |
| P1MB4PD25 | D | 25 | 10 | 4 | 3 | 0.460 |
| P1MB4PD32 | D | 32 | 10 | 4 | 3 | 0.460 |
| P1MB4PD40 | D | 40 | 10 | 4 | 3 | 0.460 |
| P1MB4PD50 | D | 50 | 10 | 4 | 3 | 0.460 |
| P1MB4PD63 | D | 63 | 10 | 4 | 3 | 0.460 |

### General characteristics

These devices are used to protect against short circuits and overloads of wiring installations and loads in panel boards, office buildings, stores and similar applications.

Their purpose is circuit protection, circuit isolation and load operation controls. They have characteristics of instantaneous trip defined as follows:

- B-curve: instantaneous trip 3...5 times  $I_n$  for non-inductive or low inductive loads (heating resistors, generators, very long wire lines)
- C-curve: instantaneous trip 5...10 times  $I_n$  for inductive loads (mixed loads, resistive and inductive with low inrush current)
- D-curve: instantaneous trip 10...14 times  $I_n$  for highly inductive loads (loads with high inrush and current such as motors).

Main features include:

- IEC rated current  $I_n$ : 1...63A
- Pole width: 17.5mm / 0.69"
- Contact status with flag indicator
- Trip characteristic: curve type B, C and D
- Auxiliary contacts and trip releases mounted on left side
- Fixing on 35mm DIN rail (IEC/EN/BS 60715).

### Operational characteristics

- Dissipation per pole: 3...13W
- IEC rated insulation voltage  $U_i$ : 440V
- IEC rated impulse voltage  $U_{imp}$ : 4kV
- IEC rated operational voltage  $U_e$ : 230/400VAC
- UL 1077 rated operational voltage: 480VAC
- Short circuit breaking capacity: IEC/EN/BS 10kA - UL 7.5kA 480V.

### Certifications and compliance

Certifications obtained: cURus (E369585); EAC; TÜV-Rheinland.

Compliant with standards: IEC/EN/BS 60898-1, IEC/EN/BS 60947-2, UL 1077, CSA C22.2 n°235.

# 14 Miniature and residual circuit breakers

Miniature circuit breakers 1...63A, UL 489

## 1P - 10kA (IEC/EN/BS) 1 module



P1MB...1P...



| Order code | Curve | IEC In | Rat. volt. | N° of DIN mod. | Qty per pkg | Wt   |
|------------|-------|--------|------------|----------------|-------------|------|
|            |       | [A]    | [V]        | n°             | n°          | [kg] |

One pole, thermal and magnetic trip type, C-curve characteristic.

|               |   |     |     |   |    |       |
|---------------|---|-----|-----|---|----|-------|
| P1MBUH1PC01   | C | 1   | 277 | 1 | 12 | 0.133 |
| P1MBUH1PC01V6 | C | 1.6 | 277 | 1 | 12 | 0.133 |
| P1MBUH1PC02   | C | 2   | 277 | 1 | 12 | 0.133 |
| P1MBUH1PC03   | C | 3   | 277 | 1 | 12 | 0.133 |
| P1MBUH1PC04   | C | 4   | 277 | 1 | 12 | 0.133 |
| P1MBUH1PC05   | C | 5   | 277 | 1 | 12 | 0.133 |
| P1MBUH1PC06   | C | 6   | 277 | 1 | 12 | 0.133 |
| P1MBUH1PC07   | C | 7   | 277 | 1 | 12 | 0.133 |
| P1MBUH1PC08   | C | 8   | 277 | 1 | 12 | 0.133 |
| P1MBUH1PC10   | C | 10  | 277 | 1 | 12 | 0.133 |
| P1MBUH1PC12   | C | 12  | 277 | 1 | 12 | 0.133 |
| P1MBUH1PC13   | C | 13  | 277 | 1 | 12 | 0.133 |
| P1MBUH1PC15   | C | 15  | 277 | 1 | 12 | 0.133 |
| P1MBUH1PC16   | C | 16  | 277 | 1 | 12 | 0.133 |
| P1MBUH1PC20   | C | 20  | 277 | 1 | 12 | 0.133 |
| P1MBUH1PC25   | C | 25  | 277 | 1 | 12 | 0.133 |
| P1MBUH1PC30   | C | 30  | 277 | 1 | 12 | 0.133 |
| P1MBUH1PC32   | C | 32  | 277 | 1 | 12 | 0.133 |
| P1MBUL1PC35   | C | 35  | 120 | 1 | 12 | 0.133 |
| P1MBUL1PC40   | C | 40  | 120 | 1 | 12 | 0.133 |
| P1MBUL1PC50   | C | 50  | 120 | 1 | 12 | 0.133 |
| P1MBUL1PC60   | C | 60  | 120 | 1 | 12 | 0.133 |
| P1MBUL1PC63   | C | 63  | 120 | 1 | 12 | 0.133 |

One pole, thermal and magnetic trip type, D-curve characteristic.

|               |   |     |     |   |    |       |
|---------------|---|-----|-----|---|----|-------|
| P1MBUH1PD01   | D | 1   | 277 | 1 | 12 | 0.133 |
| P1MBUH1PD01V6 | D | 1.6 | 277 | 1 | 12 | 0.133 |
| P1MBUH1PD02   | D | 2   | 277 | 1 | 12 | 0.133 |
| P1MBUH1PD03   | D | 3   | 277 | 1 | 12 | 0.133 |
| P1MBUH1PD04   | D | 4   | 277 | 1 | 12 | 0.133 |
| P1MBUH1PD05   | D | 5   | 277 | 1 | 12 | 0.133 |
| P1MBUH1PD06   | D | 6   | 277 | 1 | 12 | 0.133 |
| P1MBUH1PD07   | D | 7   | 277 | 1 | 12 | 0.133 |
| P1MBUH1PD08   | D | 8   | 277 | 1 | 12 | 0.133 |
| P1MBUH1PD10   | D | 10  | 277 | 1 | 12 | 0.133 |
| P1MBUH1PD12   | D | 12  | 277 | 1 | 12 | 0.133 |
| P1MBUH1PD13   | D | 13  | 277 | 1 | 12 | 0.133 |
| P1MBUH1PD15   | D | 15  | 277 | 1 | 12 | 0.133 |
| P1MBUH1PD16   | D | 16  | 277 | 1 | 12 | 0.133 |
| P1MBUH1PD20   | D | 20  | 277 | 1 | 12 | 0.133 |
| P1MBUH1PD25   | D | 25  | 277 | 1 | 12 | 0.133 |
| P1MBUH1PD30   | D | 30  | 277 | 1 | 12 | 0.133 |
| P1MBUH1PD32   | D | 32  | 277 | 1 | 12 | 0.133 |
| P1MBUL1PD35   | D | 35  | 120 | 1 | 12 | 0.133 |
| P1MBUL1PD40   | D | 40  | 120 | 1 | 12 | 0.133 |
| P1MBUL1PD50   | D | 50  | 120 | 1 | 12 | 0.133 |
| P1MBUL1PD60   | D | 60  | 120 | 1 | 12 | 0.133 |
| P1MBUL1PD63   | D | 63  | 120 | 1 | 12 | 0.133 |

### General characteristics

These devices comply with the UL 489 standard, mostly used in the North American markets. They are designed to protect feeder circuits, the part of the system from the network supply point to the protection device for a branch circuit. They can also be used on the international market thanks to compliance with the IEC/EN/BS 60947-2 standard.

They have characteristics of tripping instantaneously defined as follows:

- C-curve: instantaneous trip 5...10 times In for inductive loads (mixed loads, resistive and inductive with low inrush current)
- D-curve: instantaneous trip 10...14 times In for highly inductive loads (loads with high inrush and current such as motors).

### Operational characteristics

- Dissipation per pole: 3...13W
- Rated voltage 1...32A: 277V (UL 489)
- Rated voltage 35...63A: 120V (UL 489)
- Rated insulation voltage Ui: 440V (IEC/EN/BS 60947-2)
- Rated impulse voltage Uimp: 4kV (IEC/EN/BS 60947-2)
- Rated operational voltage Ue: 230/400VAC (IEC/EN/BS 60947-2)
- DC operational voltage: 60V
- Short circuit breaking capacity: IEC/EN/BS 10kA - UL 10kA.

### Certifications and compliance

Certifications obtained: cULus (E481234); EAC. Compliant with standards: UL 489, IEC/EN/BS 60947-2.





# 14 Miniature and residual circuit breakers

Miniature circuit breakers 1...63A, UL 489

## 2P - 10kA (IEC/EN/BS) 2 modules



P1MB...2P...

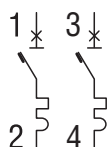

| Order code | Curve | IEC In | Rated voltage | N° of DIN mod. | Qty per pkg | Wt   |
|------------|-------|--------|---------------|----------------|-------------|------|
|            |       | [A]    | [V]           | n°             | n°          | [kg] |

Two pole, thermal and magnetic trip type, C-curve characteristic.

|               |   |     |          |   |   |       |
|---------------|---|-----|----------|---|---|-------|
| P1MBUH2PC01   | C | 1   | 480Y/277 | 2 | 6 | 0.255 |
| P1MBUH2PC01V6 | C | 1.6 | 480Y/277 | 2 | 6 | 0.255 |
| P1MBUH2PC02   | C | 2   | 480Y/277 | 2 | 6 | 0.255 |
| P1MBUH2PC03   | C | 3   | 480Y/277 | 2 | 6 | 0.255 |
| P1MBUH2PC04   | C | 4   | 480Y/277 | 2 | 6 | 0.255 |
| P1MBUH2PC05   | C | 5   | 480Y/277 | 2 | 6 | 0.255 |
| P1MBUH2PC06   | C | 6   | 480Y/277 | 2 | 6 | 0.255 |
| P1MBUH2PC07   | C | 7   | 480Y/277 | 2 | 6 | 0.255 |
| P1MBUH2PC08   | C | 8   | 480Y/277 | 2 | 6 | 0.255 |
| P1MBUH2PC10   | C | 10  | 480Y/277 | 2 | 6 | 0.255 |
| P1MBUH2PC12   | C | 12  | 480Y/277 | 2 | 6 | 0.255 |
| P1MBUH2PC13   | C | 13  | 480Y/277 | 2 | 6 | 0.255 |
| P1MBUH2PC15   | C | 15  | 480Y/277 | 2 | 6 | 0.255 |
| P1MBUH2PC16   | C | 16  | 480Y/277 | 2 | 6 | 0.255 |
| P1MBUH2PC20   | C | 20  | 480Y/277 | 2 | 6 | 0.255 |
| P1MBUH2PC25   | C | 25  | 480Y/277 | 2 | 6 | 0.255 |
| P1MBUH2PC30   | C | 30  | 480Y/277 | 2 | 6 | 0.255 |
| P1MBUH2PC32   | C | 32  | 480Y/277 | 2 | 6 | 0.255 |
| P1MBUL2PC35   | C | 35  | 240      | 2 | 6 | 0.255 |
| P1MBUL2PC40   | C | 40  | 240      | 2 | 6 | 0.255 |
| P1MBUL2PC50   | C | 50  | 240      | 2 | 6 | 0.255 |
| P1MBUL2PC60   | C | 60  | 240      | 2 | 6 | 0.255 |
| P1MBUL2PC63   | C | 63  | 240      | 2 | 6 | 0.255 |

Two pole, thermal and magnetic trip type, D-curve characteristic.

|               |   |     |          |   |   |       |
|---------------|---|-----|----------|---|---|-------|
| P1MBUH2PD01   | D | 1   | 480Y/277 | 2 | 6 | 0.255 |
| P1MBUH2PD01V6 | D | 1.6 | 480Y/277 | 2 | 6 | 0.255 |
| P1MBUH2PD02   | D | 2   | 480Y/277 | 2 | 6 | 0.255 |
| P1MBUH2PD03   | D | 3   | 480Y/277 | 2 | 6 | 0.255 |
| P1MBUH2PD04   | D | 4   | 480Y/277 | 2 | 6 | 0.255 |
| P1MBUH2PD05   | D | 5   | 480Y/277 | 2 | 6 | 0.255 |
| P1MBUH2PD06   | D | 6   | 480Y/277 | 2 | 6 | 0.255 |
| P1MBUH2PD07   | D | 7   | 480Y/277 | 2 | 6 | 0.255 |
| P1MBUH2PD08   | D | 8   | 480Y/277 | 2 | 6 | 0.255 |
| P1MBUH2PD10   | D | 10  | 480Y/277 | 2 | 6 | 0.255 |
| P1MBUH2PD12   | D | 12  | 480Y/277 | 2 | 6 | 0.255 |
| P1MBUH2PD13   | D | 13  | 480Y/277 | 2 | 6 | 0.255 |
| P1MBUH2PD15   | D | 15  | 480Y/277 | 2 | 6 | 0.255 |
| P1MBUH2PD16   | D | 16  | 480Y/277 | 2 | 6 | 0.255 |
| P1MBUH2PD20   | D | 20  | 480Y/277 | 2 | 6 | 0.255 |
| P1MBUH2PD25   | D | 25  | 480Y/277 | 2 | 6 | 0.255 |
| P1MBUH2PD30   | D | 30  | 480Y/277 | 2 | 6 | 0.255 |
| P1MBUH2PD32   | D | 32  | 480Y/277 | 2 | 6 | 0.255 |
| P1MBUL2PD35   | D | 35  | 240      | 2 | 6 | 0.255 |
| P1MBUL2PD40   | D | 40  | 240      | 2 | 6 | 0.255 |
| P1MBUL2PD50   | D | 50  | 240      | 2 | 6 | 0.255 |
| P1MBUL2PD60   | D | 60  | 240      | 2 | 6 | 0.255 |
| P1MBUL2PD63   | D | 63  | 240      | 2 | 6 | 0.255 |

### General characteristics

These devices comply with the UL 489 standard, mostly used in the North American markets. They are designed to protect feeder circuits, the part of the system from the network supply point to the protection device for a branch circuit. They can in any case be used on the international market thanks to compliance with the IEC/EN/BS 60947-2 standard as well.

They have characteristics of tripping instantaneously defined as follows:

- C-curve: instantaneous trip 5...10 times In for inductive loads (mixed loads, resistive and inductive with low inrush current)
- D-curve: instantaneous trip 10...14 times In for highly inductive loads (loads with high inrush and current such as motors).

### Operational characteristics

- Rated voltage 1...32A: 480Y/277V (UL 489)
- Rated voltage 35...63A: 240V (UL 489)
- Rated insulation voltage Ui: 440V (IEC/EN/BS 60947-2)
- Rated impulse voltage Uimp: 4kV (IEC/EN/BS 60947-2)
- Rated operational voltage Ue: 230/400VAC (IEC/EN/BS 60947-2)
- DC operational voltage: 125V
- Short circuit breaking capacity: IEC/EN/BS 10kA - UL 10kA.

### Certifications and compliance

Certifications obtained: cULus (E481234); EAC.  
Compliant with standards: UL 489, IEC/EN/BS 60947-2.



# 14 Miniature and residual circuit breakers

Miniature circuit breakers 1...63A, UL 489

## 3P - 10kA (IEC/EN/BS) 3 modules



P1MB...3P...

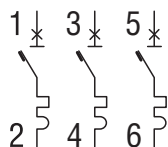

| Order code | Curve | IEC In | Rated voltage | N° of DIN mod. | Qty per pkg | Wt   |
|------------|-------|--------|---------------|----------------|-------------|------|
|            |       | [A]    | [V]           | n°             | n°          | [kg] |

Three pole, thermal and magnetic trip type, C-curve characteristic.

|               |   |     |          |   |   |       |
|---------------|---|-----|----------|---|---|-------|
| P1MBUH3PC01   | C | 1   | 480Y/277 | 3 | 4 | 0.388 |
| P1MBUH3PC01V6 | C | 1.6 | 480Y/277 | 3 | 4 | 0.388 |
| P1MBUH3PC02   | C | 2   | 480Y/277 | 3 | 4 | 0.388 |
| P1MBUH3PC03   | C | 3   | 480Y/277 | 3 | 4 | 0.388 |
| P1MBUH3PC04   | C | 4   | 480Y/277 | 3 | 4 | 0.388 |
| P1MBUH3PC05   | C | 5   | 480Y/277 | 3 | 4 | 0.388 |
| P1MBUH3PC06   | C | 6   | 480Y/277 | 3 | 4 | 0.388 |
| P1MBUH3PC07   | C | 7   | 480Y/277 | 3 | 4 | 0.388 |
| P1MBUH3PC08   | C | 8   | 480Y/277 | 3 | 4 | 0.388 |
| P1MBUH3PC10   | C | 10  | 480Y/277 | 3 | 4 | 0.388 |
| P1MBUH3PC12   | C | 12  | 480Y/277 | 3 | 4 | 0.388 |
| P1MBUH3PC13   | C | 13  | 480Y/277 | 3 | 4 | 0.388 |
| P1MBUH3PC15   | C | 15  | 480Y/277 | 3 | 4 | 0.388 |
| P1MBUH3PC16   | C | 16  | 480Y/277 | 3 | 4 | 0.388 |
| P1MBUH3PC20   | C | 20  | 480Y/277 | 3 | 4 | 0.388 |
| P1MBUH3PC25   | C | 25  | 480Y/277 | 3 | 4 | 0.388 |
| P1MBUH3PC30   | C | 30  | 480Y/277 | 3 | 4 | 0.388 |
| P1MBUH3PC32   | C | 32  | 480Y/277 | 3 | 4 | 0.388 |
| P1MBUL3PC35   | C | 35  | 240      | 3 | 4 | 0.388 |
| P1MBUL3PC40   | C | 40  | 240      | 3 | 4 | 0.388 |
| P1MBUL3PC50   | C | 50  | 240      | 3 | 4 | 0.388 |
| P1MBUL3PC60   | C | 60  | 240      | 3 | 4 | 0.388 |
| P1MBUL3PC63   | C | 63  | 240      | 3 | 4 | 0.388 |

Three pole, thermal and magnetic trip type, D-curve characteristic.

|               |   |     |          |   |   |       |
|---------------|---|-----|----------|---|---|-------|
| P1MBUH3PD01   | D | 1   | 480Y/277 | 3 | 4 | 0.388 |
| P1MBUH3PD01V6 | D | 1.6 | 480Y/277 | 3 | 4 | 0.388 |
| P1MBUH3PD02   | D | 2   | 480Y/277 | 3 | 4 | 0.388 |
| P1MBUH3PD03   | D | 3   | 480Y/277 | 3 | 4 | 0.388 |
| P1MBUH3PD04   | D | 4   | 480Y/277 | 3 | 4 | 0.388 |
| P1MBUH3PD05   | D | 5   | 480Y/277 | 3 | 4 | 0.388 |
| P1MBUH3PD06   | D | 6   | 480Y/277 | 3 | 4 | 0.388 |
| P1MBUH3PD07   | D | 7   | 480Y/277 | 3 | 4 | 0.388 |
| P1MBUH3PD08   | D | 8   | 480Y/277 | 3 | 4 | 0.388 |
| P1MBUH3PD10   | D | 10  | 480Y/277 | 3 | 4 | 0.388 |
| P1MBUH3PD12   | D | 12  | 480Y/277 | 3 | 4 | 0.388 |
| P1MBUH3PD13   | D | 13  | 480Y/277 | 3 | 4 | 0.388 |
| P1MBUH3PD15   | D | 15  | 480Y/277 | 3 | 4 | 0.388 |
| P1MBUH3PD16   | D | 16  | 480Y/277 | 3 | 4 | 0.388 |
| P1MBUH3PD20   | D | 20  | 480Y/277 | 3 | 4 | 0.388 |
| P1MBUH3PD25   | D | 25  | 480Y/277 | 3 | 4 | 0.388 |
| P1MBUH3PD30   | D | 30  | 480Y/277 | 3 | 4 | 0.388 |
| P1MBUH3PD32   | D | 32  | 480Y/277 | 3 | 4 | 0.388 |
| P1MBUL3PD35   | D | 35  | 240      | 3 | 4 | 0.388 |
| P1MBUL3PD40   | D | 40  | 240      | 3 | 4 | 0.388 |
| P1MBUL3PD50   | D | 50  | 240      | 3 | 4 | 0.388 |
| P1MBUL3PD60   | D | 60  | 240      | 3 | 4 | 0.388 |
| P1MBUL3PD63   | D | 63  | 240      | 3 | 4 | 0.388 |

### General characteristics

These devices comply with the UL 489 standard, mostly used in the North American markets. They are designed to protect feeder circuits, the part of the system from the network supply point to the protection device for a branch circuit. They can also be used on the international market thanks to compliance with the IEC/EN/BS 60947-2 standard.

They have characteristics of tripping instantaneously defined as follows:

- C-curve: instantaneous trip 5...10 times In for inductive loads (mixed loads, resistive and inductive with low inrush current)
- D-curve: instantaneous trip 10...14 times In for highly inductive loads (loads with high inrush and current such as motors).

### Operational characteristics

- Rated voltage 1...32A: 480Y/277V (UL 489)
- Rated voltage 35...63A: 240V (UL 489)
- Rated insulation voltage Ui: 440V (IEC/EN/BS 60947-2)
- Rated impulse voltage Uimp: 4kV (IEC/EN/BS 60947-2)
- Rated operational voltage Ue: 230/400VAC (IEC/EN/BS 60947-2)
- DC operational voltage: 125V
- Short circuit breaking capacity: IEC/EN/BS 10kA - UL 10kA.

### Certifications and compliance

Certifications obtained: cULus (E481234); EAC. Compliant with standards: UL 489, IEC/EN/BS 60947-2.



# 14 Miniature and residual circuit breakers

Miniature circuit breakers 80...125A, UL 1077

## 1P, 2P, 3P and 4P - 10kA (IEC/EN/BS)



P2MB1P...



P2MB2P...



P2MB3P...



P2MB4P...



| Order code | Curve | IEC In | IEC Icn | N° of DIN module | Qty per pkg | Wt   |
|------------|-------|--------|---------|------------------|-------------|------|
|            |       | [A]    | [kA]    | no.              | no.         | [kg] |

One pole, thermal and magnetic trip type, C-curve characteristic.

|                   |   |     |                 |     |   |       |
|-------------------|---|-----|-----------------|-----|---|-------|
| <b>P2MB1PC080</b> | C | 80  | 10 <sup>Ⓢ</sup> | 1.5 | 9 | 0.166 |
| <b>P2MB1PC100</b> | C | 100 | 10 <sup>Ⓢ</sup> | 1.5 | 9 | 0.166 |
| <b>P2MB1PC125</b> | C | 125 | 10 <sup>Ⓢ</sup> | 1.5 | 9 | 0.166 |

Two pole, thermal and magnetic trip type, C-curve characteristic.

|                   |   |     |    |   |   |       |
|-------------------|---|-----|----|---|---|-------|
| <b>P2MB2PC080</b> | C | 80  | 10 | 3 | 4 | 0.340 |
| <b>P2MB2PC100</b> | C | 100 | 10 | 3 | 4 | 0.340 |
| <b>P2MB2PC125</b> | C | 125 | 10 | 3 | 4 | 0.340 |

Three pole, thermal and magnetic trip type, C-curve characteristic.

|                   |   |     |    |     |   |       |
|-------------------|---|-----|----|-----|---|-------|
| <b>P2MB3PC080</b> | C | 80  | 10 | 4.5 | 3 | 0.510 |
| <b>P2MB3PC100</b> | C | 100 | 10 | 4.5 | 3 | 0.510 |
| <b>P2MB3PC125</b> | C | 125 | 10 | 4.5 | 3 | 0.510 |

Four pole, thermal and magnetic trip type, C-curve characteristic.

|                   |   |     |    |   |   |       |
|-------------------|---|-----|----|---|---|-------|
| <b>P2MB4PC080</b> | C | 80  | 10 | 6 | 2 | 0.680 |
| <b>P2MB4PC100</b> | C | 100 | 10 | 6 | 2 | 0.680 |
| <b>P2MB4PC125</b> | C | 125 | 10 | 6 | 2 | 0.680 |

Three pole, thermal and magnetic trip type, D-curve characteristic.

|                   |   |     |    |     |   |       |
|-------------------|---|-----|----|-----|---|-------|
| <b>P2MB3PD080</b> | D | 80  | 10 | 4.5 | 3 | 0.510 |
| <b>P2MB3PD100</b> | D | 100 | 10 | 4.5 | 3 | 0.510 |
| <b>P2MB3PD125</b> | D | 125 | 10 | 4.5 | 3 | 0.510 |

Four pole, thermal and magnetic trip type, D-curve characteristic.

|                   |   |     |    |   |   |       |
|-------------------|---|-----|----|---|---|-------|
| <b>P2MB4PD080</b> | D | 80  | 10 | 6 | 2 | 0.510 |
| <b>P2MB4PD100</b> | D | 100 | 10 | 6 | 2 | 0.510 |
| <b>P2MB4PD125</b> | D | 125 | 10 | 6 | 2 | 0.510 |

<sup>Ⓢ</sup> Icn at 230V.

### General characteristics

These devices are used to protect against short circuits and overloads of wiring installations and loads in panel boards, office buildings, stores and similar applications.

Their purpose is circuit protection, circuit isolation and load operation controls. They have characteristics of instantaneous trip defined as follows:

- C-curve: instantaneous trip 5...10 times In for inductive loads (mixed loads, resistive and inductive with low inrush current)
- D-curve: instantaneous trip 10...14 times In for highly inductive loads (loads with high inrush and current such as motors).

Main features include:

- IEC rated current In: 80...125A
- Pole width: 27mm / 1.06"
- Contact status with flag indicator
- Trip characteristic: curve type C and D
- Fixing on 35mm DIN rail (IEC/EN/BS 60715).

### Operational characteristics

- Dissipation per pole: 15...20W
- IEC rated insulation voltage Ui: 400V
- IEC rated impulse voltage Uimp: 4kV
- IEC rated operational voltage Ue: 230/400VAC (230VAC 1P version)
- Short circuit breaking capacity: IEC/EN/BS 10kA - UL 5kA 240V (1P) - 5kA 480V (2-3-4P).

### Certifications and compliance

Certifications obtained: cURus (E369585); EAC; TÜV-Rheinland.

Compliant with standards: IEC/EN/BS 60898-1, IEC/EN/BS 60947-2, UL 1077, CSA C22.2 n°235.

# 14 Miniature and residual circuit breakers

Add-on blocks and accessories

## Add-on blocks for miniature circuit breakers 1...63A



P1X1011

P1X16230

| Order code                                   | Description                       | Qty per MCB | Qty per pkg | Wt    |
|--|-----------------------------------|-------------|-------------|-------|
|  |                                   | n°          | n°          | [kg]  |
| Auxiliary contact.                           |                                   |             |             |       |
| <b>P1X1011</b>                               | 1 changeover contact for P1MB...  | 1           | 10          | 0.040 |
| <b>P1X1011UH</b>                             | 1 changeover contact for P1MBU... | 1           | 10          | 0.040 |
| Indicator contact for thermal-magnetic trip. |                                   |             |             |       |
| <b>P1X1311</b>                               | 1 changeover contact              | 1           | 10          | 0.040 |
| Undervoltage trip release.                   |                                   |             |             |       |
| <b>P1X14230</b>                              | 230V 50/60Hz                      | 1           | 8           | 0.070 |
| Shunt trip release.                          |                                   |             |             |       |
| <b>P1X16230</b>                              | 110...415V 50/60Hz                | 1           | 8           | 0.070 |

❶ Not suitable for P1MBU...

### General characteristics

- Auxiliary and indicator contact width: 9mm/0.35" (0.5 module)
- Undervoltage and shunt trip release width: 18mm/0.71" (1 module)
- Maximum combination: 3 add-on blocks on MCB left side only of which 1 undervoltage or shunt release directly on MCB side and then 2 contacts of which 1 auxiliary and 1 indicator.

### Operational characteristics

- IEC rated impulse voltage Uimp: 4kV
- IEC rated operational current in AC: 6A 230V; 3A 400V (auxiliary contacts).

### Certifications and compliance

Certifications obtained: EAC, cURus (excluding P1X14230), UL (only P1X14230)  
Compliant with standards: IEC/EN/BS 60947-5-1, CSA C22.2 n° 5.

## Add-on blocks for miniature circuit breakers 80...125A



P2X1311

P2X16230

| Order code                                   | Description          | Qty per MCB | Qty per pkg | Wt    |
|--|----------------------|-------------|-------------|-------|
|  |                      | n°          | n°          | [kg]  |
| Auxiliary contact.                           |                      |             |             |       |
| <b>P2X1011</b>                               | 1 changeover contact | 1           | 10          | 0.040 |
| Indicator contact for thermal-magnetic trip. |                      |             |             |       |
| <b>P2X1311</b>                               | 1 changeover contact | 1           | 10          | 0.040 |
| Shunt trip release.                          |                      |             |             |       |
| <b>P2X16230</b>                              | 110...415V 50/60Hz   | 1           | 8           | 0.070 |

### General characteristics

- Auxiliary and indicator contact width: 9mm/0.35" (0.5 module)
- Shunt trip release width: 17.5mm/0.69" (1 module)
- Maximum combination: 3 add-on blocks on MCB sides of which 1 undervoltage or shunt release on MCB right side and 2 contacts on the left of which 1 auxiliary and 1 indicator.

### Operational characteristics

- IEC rated insulation voltage Ui: 500V
- Rated impulse voltage Uimp: 4kV
- Rated operational current in AC: 6A 230V; 3A 400V (auxiliary contacts).

### Certifications and compliance

Certifications obtained: EAC.  
Compliant with standards: IEC/EN/BS 60947-5-1.





# 14 Miniature and residual circuit breakers

## Accessories

### Accessories for miniature circuit breakers

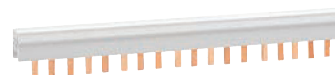

P1X9033



P1X9130



P1X9201

P1X9210

P1X9202



P1X1810

P2X1810

ⓘ Suitable for P1MB...  
Not suitable for P1MBU...

| Order code | Description  | Qty per pkg | Wt [kg] |
|------------|--|-------------|---------|
|            |  | n°          | [kg]    |
| P1X9031    | Single-pole supply busbar  | 10          | 0.160   |
| P1X9032    | Two-pole supply busbar   | 10          | 0.320   |
| P1X9033    | Three-pole supply busbar   | 10          | 0.474   |
| P1X9034    | Four-pole supply busbar  | 10          | 0.600   |
| P1X9130    | Kit of 5 isolating covers for unused busbar terminals  | 10          | 0.030   |
| P1X9131    | End cap for P1X9031  | 50          | 0.001   |
| P1X9132    | End cap for P1X9032  | 50          | 0.001   |
| P1X9133    | End cap for P1X9033  | 50          | 0.001   |
| P1X9134    | End cap for P1X9034  | 50          | 0.001   |
| P1X9201    | Single-pole terminal for busbar supply; conductor cross section 25mm <sup>2</sup> max.           | 25          | 0.010   |
| P1X9210    | 1-pole terminal for supplying busbar; conductor cross section 25mm <sup>2</sup> max.; left entry | 25          | 0.010   |
| P1X9202    | Single-pole terminal for busbar supply; conductor cross section 50mm <sup>2</sup> max.           | 25          | 0.022   |
| P1X1810    | Padlockable attachment for breaker control lever P1MB...   | 10          | 0.001   |
| P2X1810    | Padlockable attachment for breaker control lever P2MB...   | 10          | 0.002   |

### General and operational characteristics

#### SINGLE-POLE SUPPLY BUSBAR

- Rated operational voltage U<sub>e</sub>: 1000V
- Central point of power supply: 100A max.
- Side point of power supply: 63A max.
- Spacing: 17.8mm/0.70"
- Busbar section: 10mm<sup>2</sup>
- For paralleling connection
- For 57 modules, 1000mm/39.37" long (57 1P breakers).

#### TWO-POLE, THREE-POLE AND FOUR-POLE SUPPLY BUSBARS

- Rated operational voltage U<sub>e</sub>: 690V
- Central point of power supply: 100A max.
- Side point of power supply: 63A max.
- Spacing: 17.8mm/0.70"
- Busbar section: 10mm<sup>2</sup>
- For paralleling connection
- Two-pole: for 56 modules, 1000mm/39.37" long (28 2P breakers)
- Three-pole: for 57 modules, 1012mm/39.84" long (19 3P breakers)
- Four-pole: for 56 modules, 1000mm/39.37" long (14 4P breakers).

#### PADLOCKABLE ATTACHMENT

- Max. padlock diameter 5mm/0.20"
- Padlockable in ON and OFF
- One can be fitted for each pole of the breaker.

### UL approved supply busbar



3P18L57SOU50



802150S



802180



ULC...



BRU3V



802307

| Order code   | Description  | Qty per pkg | Wt [kg] |
|--|--|-------------|---------|
|  |  | n°          | [kg]    |
| Power bars for UL 1077 thermal-magnetic circuit breakers, type P1MB... |  |             |         |
| 1P18K57SOU50   | Single-pole supply busbar  | 10          | 0.160   |
| 2P18L56SOU50   | Two-pole supply busbar   | 10          | 0.320   |
| 3P18L57SOU50   | Three-pole supply busbar   | 10          | 0.474   |
| BRB5W  | Kit of 5 insulating caps for unused bar terminals  | 10          | 0.030   |
| A69  | End cap for 1P18K57SOU50   | 50          | 0.001   |
| A7   | End cap for 2P18L56SOU50 and 3P18L57SOU50  | 50          | 0.001   |
| 802150S  | Single-pole terminal block to supply busbar 1P18K57SOU50; conductor section 10 to 1 AWG                  | 25          | 0.030   |
| 802180   | Single-pole terminal block to supply busbar 2P18L56SOU50 and 3P18L57SOU50; conductor section 10 to 1 AWG | 10          | 0.030   |
| Power bars for UL 489 thermal-magnetic circuit breakers, type P1MBU... |  |             |         |
| ULC157A18A   | Single pole power bar  | 10          | 0.160   |
| ULC256A18A   | Two pole power bar   | 10          | 0.320   |
| ULC357A18A   | Three pole power bar   | 10          | 0.474   |
| BRU3V  | Kit of 3 insulating caps for unused bar terminals  | 10          | 0.022   |
| A68  | End cap for all ULC... type bars   | 50          | 0.001   |
| 802307   | Single-pole terminal block to power bars; conductor section 14 to 2 AWG                                  | 10          | 0.030   |

### Main features

- UL approved power bars are divided into two groups:
  - Bars for UL 1077 approved thermal-magnetic circuit breakers;
  - Bars for UL 489 approved thermal-magnetic circuit breaker bars.

Both models are supplied 1000mm/39.37" long and can be cut to the desired length. This feature makes it easy to adapt to any combination of installed thermal-magnetic circuit breakers. Special end caps must be applied at the points where the bars are cut, to ensure IP20 protection and to comply with UL standards.

### Operational characteristics

#### POWER BARS FOR UL APPROVED THERMAL-MAGNETIC CIRCUIT BREAKERS

- Maximum rated AC voltage: 600V
- Central power point: 160A max
- Side point for power supply: 80A max
- Spacing: 17.8mm/0.70"
- Bar section: 18mm<sup>2</sup>
- For parallel connection
- Single pole: for 57 modules, 1000mm/39.37" long (57 1P switches)
- Two pole: for 56 modules, 1000mm/39.37" long (28 2P switches)
- Three pole: for 57 modules, 1012mm/39.84" long (19 3P switches).

### Certifications

UL 508 for P18K57... bars (for use with UL 1077 approved thermal-magnetic circuit breakers).  
UL 489 for ULC... bars (for use with UL 489 approved thermal-magnetic circuit breakers).

# 14 Miniature and residual circuit breakers

Switch disconnectors.  
Residual blocks

## Switch disconnectors



P1MS1P...



P1MS2P...



P1MS3P...



P1MS4P...

**new**

## Add-on blocks for switch disconnectors P1MS...



P1X1011S



P1X1810

## Residual blocks



P1RA2P...



P1RA3P...

| Order code                         | Ie [A] | N° of DIN module | Qty per pkg | Wt [kg] |
|------------------------------------|--------|------------------|-------------|---------|
| Modular switch disconnectors - 1P. |        |                  |             |         |
| P1MS1P032                          | 32     | 1                | 12          | 0.083   |
| P1MS1P040                          | 40     | 1                | 12          | 0.083   |
| P1MS1P063                          | 63     | 1                | 12          | 0.083   |
| P1MS1P100                          | 100    | 1                | 12          | 0.083   |
| P1MS1P125                          | 125    | 1                | 12          | 0.083   |
| Modular switch disconnectors - 2P. |        |                  |             |         |
| P1MS2P032                          | 32     | 2                | 6           | 0.170   |
| P1MS2P040                          | 40     | 2                | 6           | 0.170   |
| P1MS2P063                          | 63     | 2                | 6           | 0.170   |
| P1MS2P100                          | 100    | 2                | 6           | 0.170   |
| P1MS2P125                          | 125    | 2                | 6           | 0.170   |
| Modular switch disconnectors - 3P. |        |                  |             |         |
| P1MS3P032                          | 32     | 3                | 4           | 0.250   |
| P1MS3P040                          | 40     | 3                | 4           | 0.250   |
| P1MS3P063                          | 63     | 3                | 4           | 0.250   |
| P1MS3P100                          | 100    | 3                | 4           | 0.250   |
| P1MS3P125                          | 125    | 3                | 4           | 0.250   |
| Modular switch disconnectors - 4P. |        |                  |             |         |
| P1MS4P032                          | 32     | 4                | 3           | 0.330   |
| P1MS4P040                          | 40     | 4                | 3           | 0.330   |
| P1MS4P063                          | 63     | 4                | 3           | 0.330   |
| P1MS4P100                          | 100    | 4                | 3           | 0.330   |
| P1MS4P125                          | 125    | 4                | 3           | 0.330   |

| Order code | Description  | Qty per breaker | Qty per pkg | Wt [kg] |
|------------|--|-----------------|-------------|---------|
| P1X1011S   | Auxiliary contact, 1 changeover contact                  | 1               | 1           | 0.040   |
| P1X1810    | Padlockable attachment for breaker control lever P1MS... | 1               | 10          | 0.001   |

| Order code                     | Type | IEC In [A] | IEC IΔn [mA] | N° of DIN module | Qty per pkg | Wt [kg] |
|--------------------------------|------|------------|--------------|------------------|-------------|---------|
| Residual blocks - 2P - type A. |      |            |              |                  |             |         |
| P1RA2P40A030                   | A    | 40         | 30           | 2                | 1           | 0.160   |
| P1RA2P40A300                   | A    | 40         | 300          | 2                | 1           | 0.160   |
| P1RA2P63A030                   | A    | 63         | 30           | 2                | 1           | 0.160   |
| P1RA2P63A300                   | A    | 63         | 300          | 2                | 1           | 0.160   |
| Residual blocks - 3P - type A. |      |            |              |                  |             |         |
| P1RA3P40A030                   | A    | 40         | 30           | 3.5              | 1           | 0.205   |
| P1RA3P40A300                   | A    | 40         | 300          | 3.5              | 1           | 0.205   |
| P1RA3P63A030                   | A    | 63         | 30           | 3.5              | 1           | 0.205   |
| P1RA3P63A300                   | A    | 63         | 300          | 3.5              | 1           | 0.205   |
| Residual blocks - 4P - type A. |      |            |              |                  |             |         |
| P1RA4P40A030                   | A    | 40         | 30           | 3.5              | 1           | 0.230   |
| P1RA4P40A300                   | A    | 40         | 300          | 3.5              | 1           | 0.230   |
| P1RA4P63A030                   | A    | 63         | 30           | 3.5              | 1           | 0.230   |
| P1RA4P63A300                   | A    | 63         | 300          | 3.5              | 1           | 0.230   |

### General characteristics

These devices are mainly used for disconnection and insulation of power lines and systems. They can also be used to switch various types of resistive and inductive loads.

Main features include:

- IEC rated current In: 32...125A
- Pole width: 17.5mm / 0.69"
- Clear contact status indication
- Wide terminals for easy wiring
- Auxiliary contacts can be mounted on left side and padlockable attachment
- Fixing on 35mm DIN rail (IEC/EN/BS 60715).

### Operational characteristics

- Utilisation category: AC-22A
- IEC rated insulation voltage Ui: 1000V
- IEC rated impulse voltage Uimp: 4kV
- IEC rated operational voltage Ue: 1P 230...240V; 2P, 3P, 4P 400...440V
- IEC rated short-time withstand current Icw: 12xIe (for 1 second).

### Certifications and compliance

Certifications obtained: TÜV-Rheinland, EAC.  
Compliant with standards: IEC/EN/BS 60947-3.

### General characteristics

These devices are intended for the protection of people against indirect contact (electric shock) and of installations against fire hazards due to a persistent earth/ground fault current.

They snap onto the P1MB... series thermal-magnetic circuit breakers; this combination forms a single device to protect people, protect against fire and protect lines.

### Operational characteristics

- IEC rated insulation voltage Ui: 400V
- IEC rated impulse voltage Uimp: 4kV
- IEC rated frequency: 50/60Hz
- IEC rated operational voltage Ue: 230/400V
- IEC rated residual current for tripping IΔn: 30mA; 300mA
- Dissipation per pole: 1.6W (40A), 2.7W (63A).

### Certifications and compliance

Compliance with standards: IEC/EN/BS 61009-1.  
Certifications obtained: TÜV-SUD, EAC.





# 14 Miniature and residual circuit breakers

## Residual current operated circuit breakers

### Residual current operated circuit breakers (RCCB)



P1RD2P...

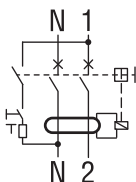

P1RD4P...

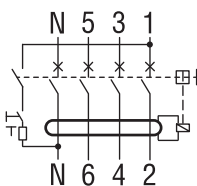

P1RC4PB...

### Add-on blocks for P1RD...



P1X1011

P1X16230

| Order code | Type | IEC In | IEC IΔn | N° of DIN module | Qty per pkg | Wt   |
|------------|------|--------|---------|------------------|-------------|------|
|            |      | [A]    | [mA]    | n°               | n°          | [kg] |

Two pole RCCB type AC.

|               |    |    |     |   |   |       |
|---------------|----|----|-----|---|---|-------|
| P1RD2P25AC030 | AC | 25 | 30  | 2 | 1 | 0.185 |
| P1RD2P25AC300 | AC | 25 | 300 | 2 | 1 | 0.185 |
| P1RD2P40AC030 | AC | 40 | 30  | 2 | 1 | 0.185 |
| P1RD2P40AC300 | AC | 40 | 300 | 2 | 1 | 0.185 |
| P1RD2P63AC030 | AC | 63 | 30  | 2 | 1 | 0.185 |
| P1RD2P63AC300 | AC | 63 | 300 | 2 | 1 | 0.185 |

Two pole RCCB type A.

|              |   |    |     |   |   |       |
|--------------|---|----|-----|---|---|-------|
| P1RD2P25A030 | A | 25 | 30  | 2 | 1 | 0.185 |
| P1RD2P25A300 | A | 25 | 300 | 2 | 1 | 0.185 |
| P1RD2P40A030 | A | 40 | 30  | 2 | 1 | 0.185 |
| P1RD2P40A300 | A | 40 | 300 | 2 | 1 | 0.185 |
| P1RD2P63A030 | A | 63 | 30  | 2 | 1 | 0.185 |
| P1RD2P63A300 | A | 63 | 300 | 2 | 1 | 0.185 |

**new**

Four pole RCCB type AC.

|               |    |    |     |   |   |       |
|---------------|----|----|-----|---|---|-------|
| P1RD4P25AC030 | AC | 25 | 30  | 4 | 1 | 0.326 |
| P1RD4P25AC300 | AC | 25 | 300 | 4 | 1 | 0.326 |
| P1RD4P40AC030 | AC | 40 | 30  | 4 | 1 | 0.326 |
| P1RD4P40AC300 | AC | 40 | 300 | 4 | 1 | 0.326 |
| P1RD4P63AC030 | AC | 63 | 30  | 4 | 1 | 0.326 |
| P1RD4P63AC300 | AC | 63 | 300 | 4 | 1 | 0.326 |

Four pole RCCB type A.

|              |   |    |     |   |   |       |
|--------------|---|----|-----|---|---|-------|
| P1RD4P25A030 | A | 25 | 30  | 4 | 1 | 0.326 |
| P1RD4P25A300 | A | 25 | 300 | 4 | 1 | 0.326 |
| P1RD4P40A030 | A | 40 | 30  | 4 | 1 | 0.326 |
| P1RD4P40A300 | A | 40 | 300 | 4 | 1 | 0.326 |
| P1RD4P63A030 | A | 63 | 30  | 4 | 1 | 0.326 |
| P1RD4P63A300 | A | 63 | 300 | 4 | 1 | 0.326 |

Four pole RCCB type B.

|              |   |    |     |   |   |       |
|--------------|---|----|-----|---|---|-------|
| P1RC4P40B030 | B | 40 | 30  | 4 | 1 | 0.335 |
| P1RC4P40B300 | B | 40 | 300 | 4 | 1 | 0.335 |
| P1RC4P63B030 | B | 63 | 30  | 4 | 1 | 0.335 |
| P1RC4P63B300 | B | 63 | 300 | 4 | 1 | 0.335 |
| P1RC4P80B030 | B | 80 | 30  | 4 | 1 | 0.335 |
| P1RC4P80B300 | B | 80 | 300 | 4 | 1 | 0.335 |

### General characteristics

These RCCBs are intended for the protection of people against indirect contact (electric shock) and of installations against fire hazards due to a persistent earth/ground fault current. Specifically to prevent electric shock, RCCBs must be rated with a rated residual current (IΔn) not exceeding 30mA so that these devices trip in the case of earth/ground fault only. They usually are connected in series with thermal-magnetic breakers which assure short circuit and overcurrent protection too. P1RC types have a IΔn of either 30mA or 300mA and are available with three different versions of residual current tripping, as follows:

Type AC – Tripping for earth/ground fault is ensured “for residual sinusoidal alternating currents, suddenly applied or slowly rising”. The symbol identifying Type AC is the following:

Type A – Tripping for earth/ground fault is ensured “for residual sinusoidal alternating currents and pulsating direct currents, suddenly applied or slowly rising”. In addition to the protection given by Type AC, this version protects against residual current with pulsating waveform. This can be caused by circuits connected with electronic equipment. The symbol identifying Type A is the following:

Type B – tripping is ensured for all conditions already covered by types AC and A. They also ensure tripping for high-frequency leakage currents up to 1000Hz and direct currents. They are particularly suitable for applications with inverters, UPSs and electric vehicle charging stations. The symbol identifying Type B is the following:

Main features include:

- IEC rated current In: 25A, 40A and 63A
- Versions: 2P and 4P
- Type of operation: AC, A and B
- Pole width: 17.5mm / 0.69"
- Contact status with flag indicator
- Fixing on 35mm DIN rail (IEC/EN/BS 60715).

### Operational characteristics

- Dissipation per pole:
  - 1.1W for P1RC2/4P25... type AC or A
  - 2.9W for P1RC2/4P40... type AC, A or B
  - 7.2W for P1RC2/4P63... type AC, A or B
  - 9.7W for P1RC/4P80... type B
- IEC rated insulation voltage Ui: 400V
- IEC rated impulse voltage Uimp: 4kV
- IEC rated frequency: 50/60Hz
- IEC rated operational voltage Uc: 230VAC for 2P; 230/400VAC for 4P
- IEC rated residual operating voltage Ue: IΔn: 30mA; 300mA
- IEC short-circuit breaking capacity Icn: 10kA

### Certifications and compliance

Certifications obtained: TÜV-Rheinland (types AC and A), EAC. Compliant with standards: IEC/EN/BS 61008-1, IEC/EN/BS 61008-2-1 (all types); IEC/EN/BS 62423 (type B).

### General characteristics

- Auxiliary and indicator contact width: 9mm/0.35" (0.5 module)
- Undervoltage and shunt trip release width: 18mm/0.71" (1 module)
- Maximum combination: 3 add-on blocks on MCB left side only of which 1 undervoltage or shunt release directly on MCB side and then 2 contacts of which 1 auxiliary and 1 indicator.

### Operational characteristics

- IEC rated impulse voltage Uimp: 4kV
- IEC rated operational current in AC: 6A 230V; 3A 400V (auxiliary contacts).

### Certifications and compliance

Certifications obtained: EAC, cURus (excluding P1X14230), UL (only P1X14230). Compliant with standards: IEC/EN/BS 60947-5-1, CSA C22.2 n° 5.

| Order code | Description | Qty per MCB | Qty per pkg | Wt   |
|------------|-------------|-------------|-------------|------|
|            |             | n°          | n°          | [kg] |

Auxiliary contact.

|         |                      |   |    |       |
|---------|----------------------|---|----|-------|
| P1X1011 | 1 changeover contact | 1 | 10 | 0.040 |
|---------|----------------------|---|----|-------|

Indicator contact for thermal-magnetic trip.

|         |                      |   |    |       |
|---------|----------------------|---|----|-------|
| P1X1311 | 1 changeover contact | 1 | 10 | 0.040 |
|---------|----------------------|---|----|-------|

Undervoltage trip release.

|          |              |   |   |       |
|----------|--------------|---|---|-------|
| P1X14230 | 230V 50/60Hz | 1 | 8 | 0.070 |
|----------|--------------|---|---|-------|

Shunt trip release.

|          |                    |   |   |       |
|----------|--------------------|---|---|-------|
| P1X16230 | 110...415V 50/60Hz | 1 | 8 | 0.070 |
|----------|--------------------|---|---|-------|

Padlockable attachment

|         |  |   |    |       |
|---------|--|---|----|-------|
| P1X1810 | Padlockable attachment for breaker control lever | 1 | 10 | 0.001 |
|---------|--|---|----|-------|

# 14 Miniature and residual circuit breakers

Residual current operated circuit breakers with overcurrent protection

## 1P+N - 10kA 2 modules



P1RE1N...

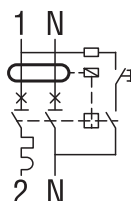

**new**

| Order code | Curve | IEC In | IEC Icn | IEC IΔn | Mod. DIN | Qty per pkg | Wt   |
|------------|-------|--------|---------|---------|----------|-------------|------|
|            |       | [A]    | [kA]    | [mA]    | n°       | n°          | [kg] |

Single pole + neutral RCBO type AC.

|                |   |    |    |     |   |   |       |
|----------------|---|----|----|-----|---|---|-------|
| P1RE1NC06AC030 | C | 6  | 10 | 30  | 2 | 1 | 0.205 |
| P1RE1NC06AC300 | C | 6  | 10 | 300 | 2 | 1 | 0.205 |
| P1RE1NC10AC030 | C | 10 | 10 | 30  | 2 | 1 | 0.205 |
| P1RE1NC10AC300 | C | 10 | 10 | 300 | 2 | 1 | 0.205 |
| P1RE1NC16AC030 | C | 16 | 10 | 30  | 2 | 1 | 0.205 |
| P1RE1NC16AC300 | C | 16 | 10 | 300 | 2 | 1 | 0.205 |
| P1RE1NC20AC030 | C | 20 | 10 | 30  | 2 | 1 | 0.205 |
| P1RE1NC20AC300 | C | 20 | 10 | 300 | 2 | 1 | 0.205 |
| P1RE1NC25AC030 | C | 25 | 10 | 30  | 2 | 1 | 0.205 |
| P1RE1NC25AC300 | C | 25 | 10 | 300 | 2 | 1 | 0.205 |
| P1RE1NC32AC030 | C | 32 | 10 | 30  | 2 | 1 | 0.205 |
| P1RE1NC32AC300 | C | 32 | 10 | 300 | 2 | 1 | 0.205 |
| P1RE1NC40AC030 | C | 40 | 10 | 30  | 2 | 1 | 0.205 |
| P1RE1NC40AC300 | C | 40 | 10 | 300 | 2 | 1 | 0.205 |

Single pole + neutral RCBO type A.

|               |   |    |    |     |   |   |       |
|---------------|---|----|----|-----|---|---|-------|
| P1RE1NC06A030 | C | 6  | 10 | 30  | 2 | 1 | 0.205 |
| P1RE1NC06A300 | C | 6  | 10 | 300 | 2 | 1 | 0.205 |
| P1RE1NC10A030 | C | 10 | 10 | 30  | 2 | 1 | 0.205 |
| P1RE1NC10A300 | C | 10 | 10 | 300 | 2 | 1 | 0.205 |
| P1RE1NC13A030 | C | 13 | 10 | 30  | 2 | 1 | 0.205 |
| P1RE1NC16A030 | C | 16 | 10 | 30  | 2 | 1 | 0.205 |
| P1RE1NC16A300 | C | 16 | 10 | 300 | 2 | 1 | 0.205 |
| P1RE1NC20A030 | C | 20 | 10 | 30  | 2 | 1 | 0.205 |
| P1RE1NC20A300 | C | 20 | 10 | 300 | 2 | 1 | 0.205 |
| P1RE1NC25A030 | C | 25 | 10 | 30  | 2 | 1 | 0.205 |
| P1RE1NC25A300 | C | 25 | 10 | 300 | 2 | 1 | 0.205 |
| P1RE1NC32A030 | C | 32 | 10 | 30  | 2 | 1 | 0.205 |
| P1RE1NC32A300 | C | 32 | 10 | 300 | 2 | 1 | 0.205 |
| P1RE1NC40A030 | C | 40 | 10 | 30  | 2 | 1 | 0.205 |
| P1RE1NC40A300 | C | 40 | 10 | 300 | 2 | 1 | 0.205 |

### General characteristics

These devices both detect and trip in the event of residual current and protect circuits in the case of short circuits and overcurrent. From a practical point of view, they integrate both functions of MCB and RCCB.

They have a C-type trip characteristic (instantaneous trip 5-10 times In) and are used for inductive loads (mixed loads, resistive and inductive with low inrush current).

In addition, they have a rated residual current (IΔn) of either 30mA or 300mA and are available with two different versions of residual current tripping type AC or A as described on page 14-14.

Its main features are:

- IEC rated current In: 6...40A
- Version: 1P+N
- Contact status with flag indicator
- Double control lever to distinguish the residual current tripping from short circuit or overcurrent tripping
- Trip characteristic: curve type C
- Fixing on 35mm DIN rail (IEC/EN/BS 60715).

### Operational characteristics

- Dissipation per pole: 3...13W
- Rated insulation voltage Ui: 400V
- Rated impulse voltage Uimp: 4kV
- Operating frequency: 50/60Hz
- Rated operational voltage Ue: 230VAC
- Rated residual operating voltage IΔn: 30mA; 300mA
- IEC short-circuit breaking capacity Icn: 10kA

### Certifications and compliance

Certifications obtained: TÜV Rheinland, EAC. Compliant with standards: IEC/EN/BS 61009-1, IEC/EN/BS 61009-2-1.

## Add-on blocks for P1RE...



P1X1011



P1X16230

| Order code | Description | Qty per MCB | Qty per pkg | Wt   |
|------------|-------------|-------------|-------------|------|
|            |             | n°          | n°          | [kg] |

Auxiliary contact.

|         |                      |   |    |       |
|---------|----------------------|---|----|-------|
| P1X1011 | 1 changeover contact | 1 | 10 | 0.040 |
|---------|----------------------|---|----|-------|

Indicator contact for thermal-magnetic trip.

|         |                      |   |    |       |
|---------|----------------------|---|----|-------|
| P1X1311 | 1 changeover contact | 1 | 10 | 0.040 |
|---------|----------------------|---|----|-------|

Undervoltage trip release.

|          |              |   |   |       |
|----------|--------------|---|---|-------|
| P1X14230 | 230V 50/60Hz | 1 | 8 | 0.070 |
|----------|--------------|---|---|-------|

Shunt trip release.

|          |                    |   |   |       |
|----------|--------------------|---|---|-------|
| P1X16230 | 110...415V 50/60Hz | 1 | 8 | 0.070 |
|----------|--------------------|---|---|-------|

Padlockable attachment

|         |  |   |    |       |
|---------|--|---|----|-------|
| P1X1810 | Padlockable attachment for breaker control lever | 1 | 10 | 0.001 |
|---------|--|---|----|-------|

### General characteristics

- Auxiliary and indicator contact width: 9mm/0.35" (0.5 module)
- Undervoltage and shunt trip release width: 18mm/0.71" (1 module)
- Maximum combination: 3 add-on blocks on MCB left side only of which 1 undervoltage or shunt release directly on MCB side and then 2 contacts of which 1 auxiliary and 1 indicator.

### Operational characteristics

- IEC rated impulse voltage Uimp: 4kV
- IEC rated operational current in AC: 6A 230V; 3A 400V (auxiliary contacts).

### Certifications and compliance

Certifications obtained: EAC, cURus (excluding P1X14230), UL (only P1X14230) Compliant with standards: IEC/EN/BS 60947-5-1, CSA C22.2 n° 5.







# 14 Miniature and residual circuit breakers

Dimensions [mm (in)]



## MINIATURE CIRCUIT BREAKERS

**P1MB...**

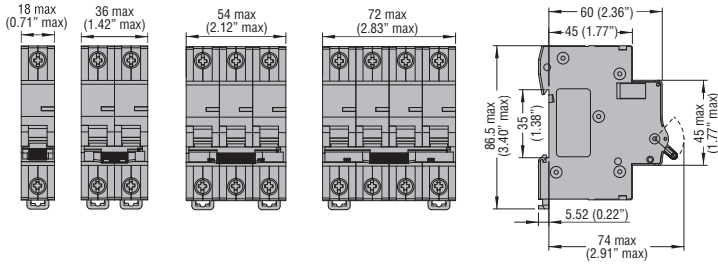

**P1MBUH... - P1MBUL...**

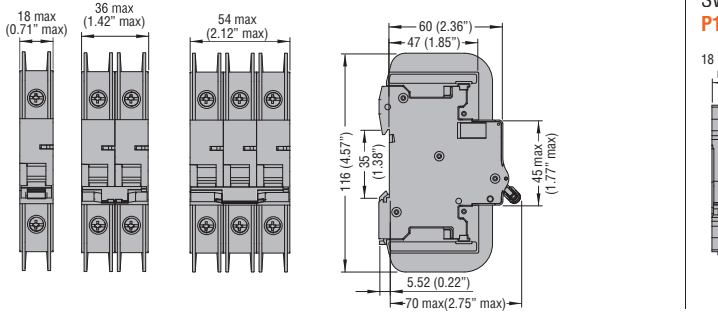

## ACCESSORIES

Add-on contacts

**P1X1011 - P1X0111S - P1X1011UH - P1X1311**

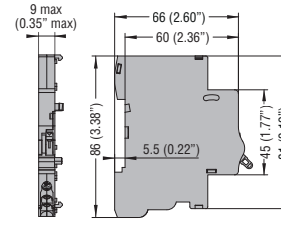

Undervoltage and shunt releases

**P1X14230 - P1X16230**

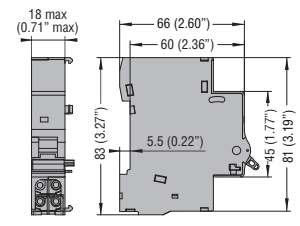

## SWITCH DISCONNECTORS

**P1MS...**

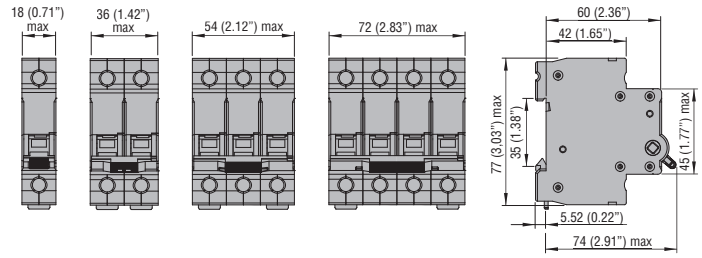

## MINIATURE CIRCUIT BREAKERS

**P2MB...**

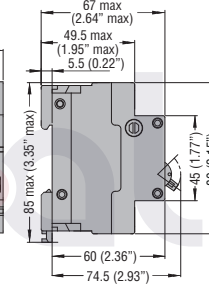
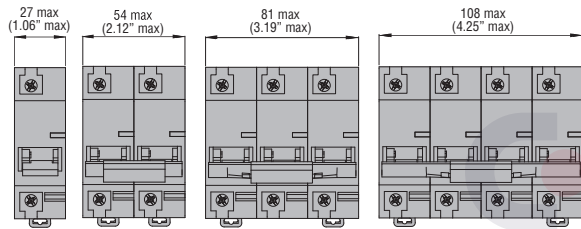

## ACCESSORIES

Add-on contacts

**P2X1011 - P2X1311**

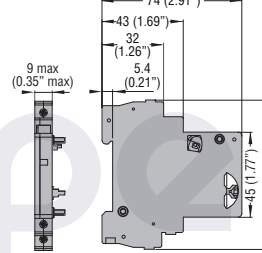

Shunt release

**P2X16230**

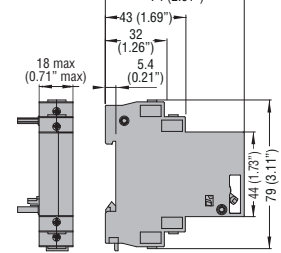

## RESIDUAL BLOCKS

**P1RA**

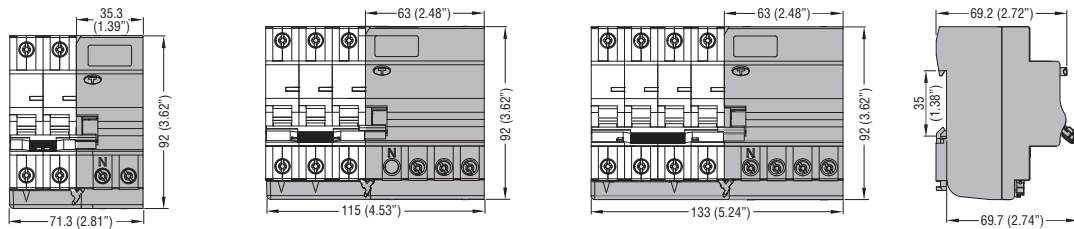

## RESIDUAL CURRENT OPERATED CIRCUIT BREAKERS

**P1RD...**

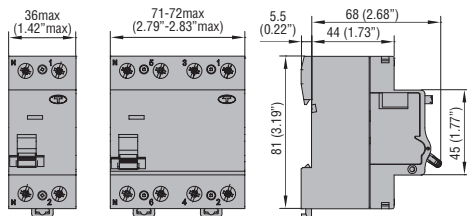

## RESIDUAL CURRENT OPERATED CIRCUIT BREAKERS WITH OVERCURRENT PROTECTION

**P1RE...**

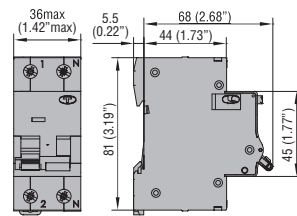

## Wiring diagrams

**P1X1011 - P1X1011S - P1X1011UH - P2X1011**

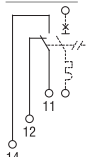

**P1X1311 - P2X1311**

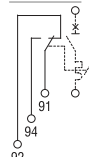

**P1X14230**

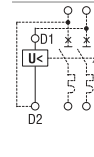

**P1X16230 - P2X16230**

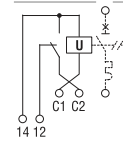



# 14 Miniature and residual circuit breakers

## Technical characteristics



| TYPE  |                 | P1MB1M...                             | P1MB1N...                                  | P1MB...P...   | P2MB   | P1MS...                       | P1RA                                   | P1RD...                                    | P1RE...   |           |
|---|-----------------|---------------------------------------|--|---|--|-------------------------------|--|--|---|-----------|
| Description                                   |                 | Miniature circuit breakers            | Miniature circuit breakers                 | Miniature circuit breakers  | Miniature circuit breakers                       | Switch disconnectors          | Residual blocks                        | Residual current operated circuit breakers | Residual current operated circuit breakers w/ overcurrent prot. |           |
| Standards                                     |                 | IEC/EN/BS 60898, IEC/EN/BS 60947-2    | IEC/EN/BS 60898, IEC/EN/BS 60947-2         | IEC/EN/BS 60898, IEC/EN/BS 60947-2 UL 1077 - UL 489 <sup>①</sup>    | IEC/EN/BS 60947-2 UL 1077                        | IEC/EN/BS 60947-3             | IEC/EN/BS 61008-1 IEC/EN/BS 61008-2-1  | IEC/EN/BS 61008-1 IEC/EN/BS 61008-2-1      | IEC/EN/BS 61009-2-1   |           |
| IEC rated insulation voltage $U_i$            | V               | 500                                   | 230  | 1000  | 400  | 1000                          | 400                                    | 400  | 400   |           |
| IEC rated impulse withstand voltage $U_{imp}$ | kV              | 4                                     | 4  | 4   | 6  | 4                             | 4                                      | 4  | 4   |           |
| IEC rated operational voltage $U_e$           | in AC           | V                                     | 230  | 230   | 230 (1P, 1P+N) 230/400 (2P, 3P, 4P) <sup>②</sup> | 230 (1P) 230/400 (2P, 3P, 4P) | 230...240 (1P) 400...440V (2P, 3P, 4P) | 230 (2P) 230/400 (3P, 4P)                  | 230 (2P) 230/400(4P)  | 230       |
|   | in DC           | V                                     | —  | —   | 80 (1P, 2P) <sup>④</sup>                         | 80(1P)/125(2P) <sup>⑤</sup>   | —                                      | —  | —   |           |
| Rated frequency                               | Hz              | 50/60                                 | 50/60                                      | 50/60   | 50/60  | 50/60                         | 50/60                                  | 50/60                                      | 50/60   |           |
| Maximum rated current                         | A               | 40                                    | 63   | 63  | 125  | 125                           | 63                                     | 63   | 40  |           |
| Available rated current for types             | A               | 2, 4, 6, 10, 13, 16, 20, 25, 32, 40   | 1, 2, 4, 6, 10, 16, 20, 25, 32, 40, 50, 63 | 1, 1.6, 3, 4, 6, 8, 10, 13, 16, 20, 25, 32, 40, 50, 63 <sup>②</sup> | 80, 100, 125                                     | 30, 40, 63, 100, 125          | 40, 63                                 | 25, 40, 63 (80A B type only)               | 6, 10, 16, 20, 25, 32, 40                                       |           |
| Versions                                      |                 | 1P+N                                  | 1P+N                                       | 1P, 2P, 3P, 4P  | 1P, 2P, 3P, 4P                                   | 1P, 2P, 3P, 4P                | 2P, 3P, 4P                             | 2P, 4P                                     | 1P+N  |           |
| Tripping characteristic                       | curve           | B-C                                   | C  | B-C-D   | C-D  | —                             | —                                      | —  | C   |           |
| Instantaneous tripping                        |                 | Curve B: 3...5In<br>Curve C: 5...10In | Curve B: 3...5In<br>Curve C: 5...10In      | Curve B: 3...5In<br>Curve C: 5...10In<br>Curve D: 10...14In         | Curve C: 5...10In<br>Curve D: 10...14In          | —                             | —                                      | —  | Curve C: 5...10In   |           |
| Residual operation characteristic             | type            | —                                     | —  | —   | —  | —                             | A                                      | AC, A, B                                   | AC, A   |           |
| Rated residual current $I_{\Delta n}$         | mA              | —                                     | —  | —   | —  | —                             | 30, 300                                | 30, 300                                    | 30, 300   |           |
| Short circuit capacity (IEC/EN/BS)            | kA              | 6 (Icn/Icu)                           | 6 (Icn/Icu)                                | 10 (Icn/Icu)  | 10 (Icu)   | —                             | —                                      | 10 (Inc)                                   | 10 (Icn)  |           |
| Short circuit capacity (UL)                   | kA              | —                                     | —  | 7.5 (1P 240V)<br>5 (1P 277V)<br>7.5 (2,3,4P 480V)                   | 5  | —                             | —                                      | —  | —   |           |
| Mechanical life                               | cycle           | 20,000                                | 20,000                                     | 20,000  | 10,000   | 20,000                        | 10,000                                 | 4,000                                      | 20,000  |           |
| Maximum tightening torque of terminals        | Nm              | 1.2                                   | 2  | 2   | 3.5  | 3.5                           | 2                                      | 2  | 2   |           |
|   | lb.in           | 10                                    | 15   | 15  | 31   | 31                            | 15                                     | 15   | 15  |           |
|   | Tool            | PZ2                                   | Pz2  | PZ2   | PZ2  | PZ2                           | PZ2                                    | PZ2  | PZ2   |           |
| Conductor section min...max.                  | mm <sup>2</sup> | 1...16                                | 1...35                                     | 1...35  | 2,5...50   | 1...50                        | 1...25                                 | 2,5...35                                   | 1...16  |           |
|   | AWG             | 14...6                                | 14...2                                     | 14...2  | 14...1/0   | 16...1                        | 14...6                                 | 14...2                                     | 16...3  |           |
| <b>AMBIENT CONDITIONS</b>                     |                 |                                       |  |   |  |                               |  |  |   |           |
| Temperature                                   | Operating       | °C                                    | -40...+70                                  | -40...+70   | -40...+70  | -40...+70                     | -25...+70                              | -25...+60                                  | -25...+60   | -25...+60 |
|   | Storage         | °C                                    | -40...+80                                  | -40...+80   | -40...+80  | -40...+80                     | -25...+70                              | -40...+80                                  | -40...+80   | -40...+80 |
| Max. altitude                                 | m               | 2,000                                 | 2,000                                      | 2,000   | 2,000  | 2,000                         | 2,000                                  | 2,000                                      | 2,000   |           |
| Pollution degree                              |                 | 2                                     | 2  | 2   | 3  | 3                             | 2                                      | 2  | 2   |           |
| Mounting                                      |                 | 35mm DIN rail (IEC/EN/BS 60715)       |  |   |  |                               |  |  |   |           |

14

### TRIP CHARACTERISTICS

#### Curve B

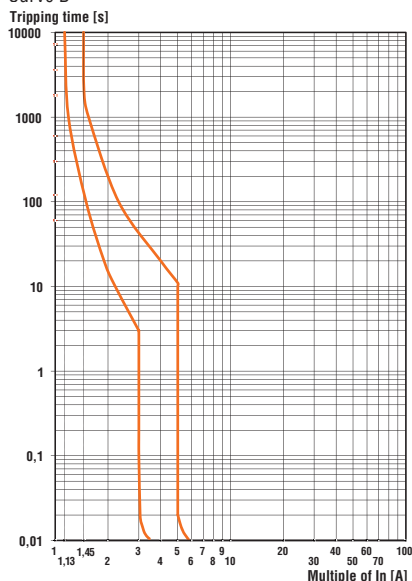

#### Curve C

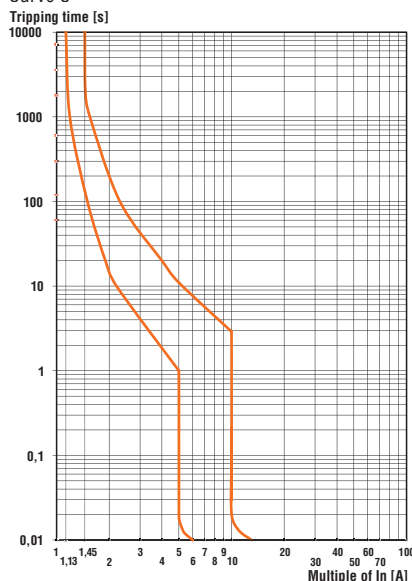

#### Curve D

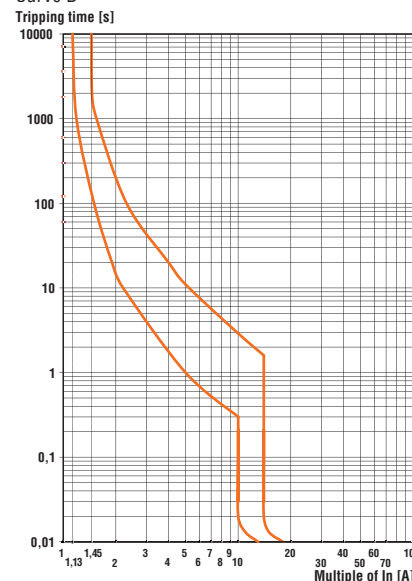

① UL489 only P1MBU... version; for the operational voltages for these devices refer to the pages for the chosen product.  
 ② For the UL 489, P1MBU... versions, the following rated current currents are also available: 5, 7, 12, 15, 30, 35, 60 A.  
 ③ For the UL 489, P1MBU... versions to 32A: 1P 277V; 2P and 3P 480V/277V. From 35 to 63A: 1P 120V; 2P and 3P 240V.  
 ④ For the UL 489, P1MBU..., 1P 60VDC and 2P 125VDC.  
 ⑤ For the UL 1077: 60VDC.