



Motor protective  
circuit breaker  
SM1R

Product designation

Product type designation

**Electrical features**

Number of poles	nr.	3
Magnetic protection		yes
Thermal protection		yes
Phase failure detection		Yes
Rated insulation voltage $U_i$ IEC/EN	V	690
Rated impulse withstand voltage $U_{imp}$	kV	6
Rated frequency	Hz	50/60
Thermal trip adjustment range		17...23
Rated current ( $I_n$ )	A	23
Magnetic tripping		13 x $I_n$
Total power dissipation	W	3.41

Operational short-circuit current breaking capacity ( $I_{cs}$ ) at AC

230V	kA	100
400V	kA	25
440V	kA	5
500V	kA	5
690V	kA	2

Maximum short-circuit current breaking capacity ( $I_{cu}$ ) at AC

230V	kA	100
400V	kA	25
440V	kA	50
500V	kA	10
690V	kA	4

Tripping class

10A

IEC Utilization category

A

**Operations**

Mechanical life	cycles	100000
Electrical life	cycles	100000

**Mechanical features**

Tightening torque for terminals

min	Nm	2.5
max	Nm	3
min	lbin	1.8
max	lbin	2.2

Max number of wires simultaneously connectable

nr. 2

Conductor section

AWG/Kcmil

min	16
max	8

Flexible w/o lug conductor section

min	mm <sup>2</sup>	1
-----	-----------------	---



Flexible c/w lug conductor section	min	mm <sup>2</sup>	1
Flexible with insulated spade lug conductor section	min	mm <sup>2</sup>	1
Screwdriver			PH2
Power terminal protection according to IEC/EN 60529			IP20
Cable stripping length	main circuit	mm	1

**Ambient conditions**

Temperature			
Operating temperature			
	min	°C	-20
	max	°C	60
Storage temperature			
	min	°C	-50
	max	°C	80
Compensation temperature			
	min	°C	-20
	max	°C	50
Max altitude		m	3000

Operating position	normal allowable	Vertical plan Any
Fixing		Screw / DIN rail 35mm
Weight	g	390

**UL technical data**

Motor Disconnect			
	at 480V	kA	30
	at 600V	kA	30
	protection		200A class J
Group Motor Installation			
	at 480V	kA	30
	at 600V	kA	30
	protection		200A class J
Maximum UL/CSA horsepower ratings single-phase			
	110V-120V	HP	1.5
	220V-240V	HP	3
Maximum UL/CSA horsepower ratings three-phase, 3-pole			
	200V-208V	HP	5
	220V-240V	HP	7.5
	440V-480V	HP	15
	550V-600V	HP	20

**Dimensions**

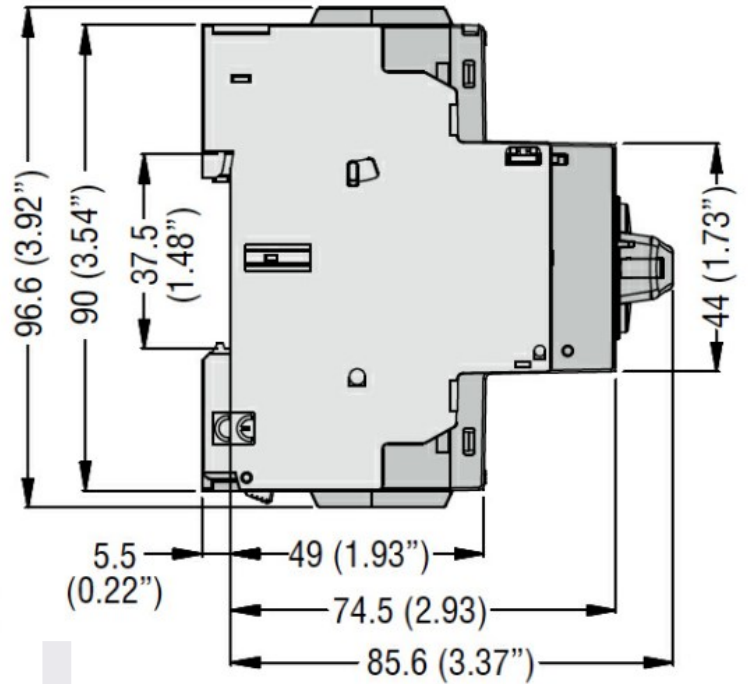
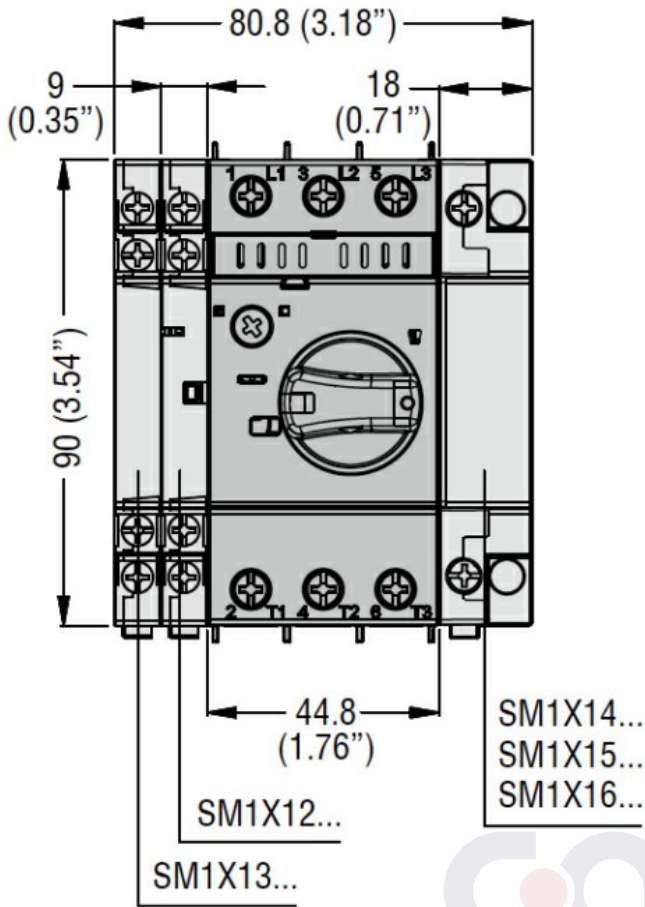

Wiring diagrams

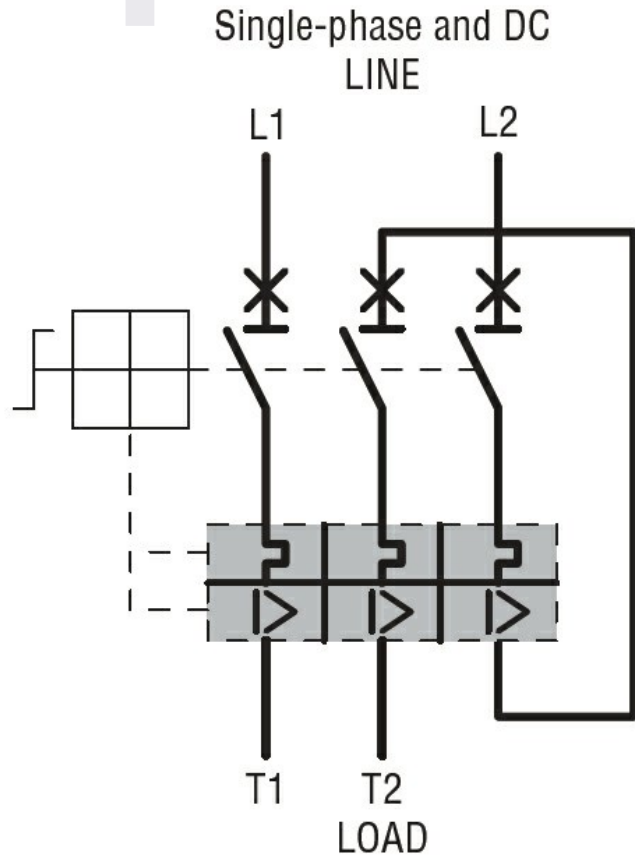
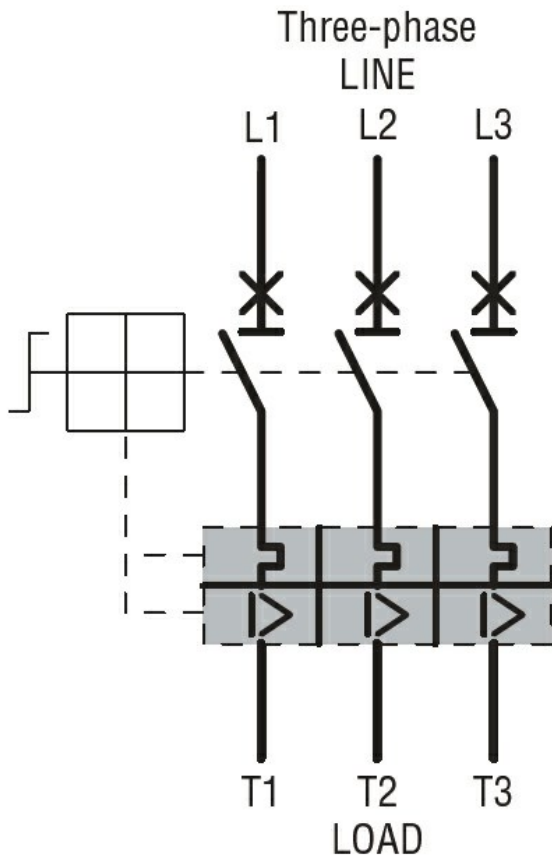

Certifications and compliance



**SM1R2300**  
 MOTOR PROTECTION CIRCUIT BREAKER, IEC BREAKING CAPACITY ICU 50KA AT 400V,  
 17...23A

Certifications

CSA C22.2 n° 14

IEC/EN 60947-1

IEC/EN 60947-2

IEC/EN 60947-4-1

UL508

Compliance

cULus

EAC

ETIM classification

ETIM 8.0

EC000074 -  
 Motor protection  
 circuit-breaker

