

Enlarger

xxxx PAzz EPg

Enlarger	Polyamide PA6 GF30
External thread	Pg as per DIN 40430
Internal thread	Pg as per DIN 40430



Properties

Temperature range	-30 °C +100 °C
Protection grade	dependent on the combination with other components

- enlarger for threaded or clearance holes to larger thread size

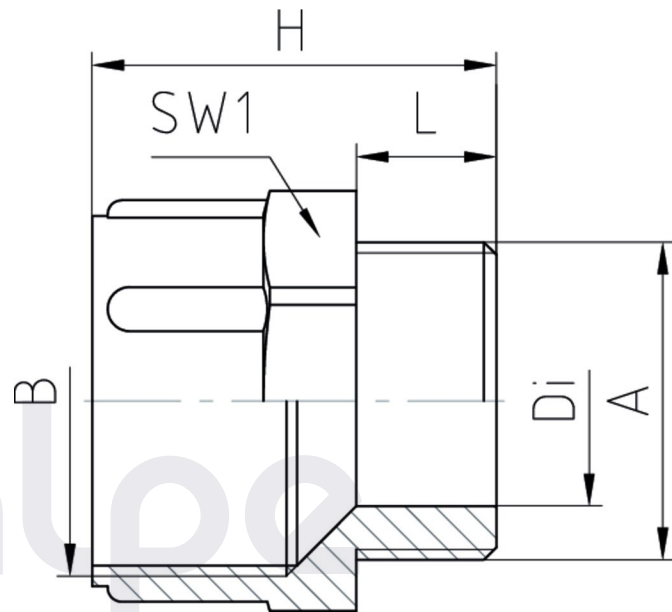

Features

 RAL 7035

A	B	L	SW1	H	Di		Part No.
Pg 7	Pg 9	8	19	21	8,5	100	709 PA
Pg 9	Pg 11	8	22	23	10	100	911 PA
Pg 11	Pg 13,5	8	24	23	13,5	100	1113 PA
Pg 11	Pg 16	8	27	24,5	12,5	100	1116 PA
Pg 13,5	Pg 16	9	27	26	15	100	1316 PA
Pg 16	Pg 21	9	32	29	16	100	1621 PA
Pg 21	Pg 29	10	42	32	22,5	50	2129 PA
Pg 29	Pg 36	11	53	35,5	30,5	25	2936 PA
Pg 36	Pg 42	13	60	40,5	39,5	10	3642 PA
Pg 42	Pg 48	13	65	41	45,5	10	4248 PA

Jacob

calpe